

THIS MANUAL IS AN ONLINE BACKUP TO YOUR
ORIGINAL HARDCOPY VERSION.

RX7CITY.COM ASSUMES NO RESPONSIBILITY IN HOW YOU USE
THIS MANUAL. THIS MANUAL IS FOR EXPERIENCED MECHANICS
AND IS TO BE USED AT YOUR OWN RISK!



Before beginning any service procedure, refer to the 1993 RX-7 Body Electrical Troubleshooting Manual; see section S for air bag system precautions and J1 for audio anti-theft system precautions.

MANUAL TRANSMISSION (R15M-D)

INDEX	J - 2
OUTLINE	J - 3
SPECIFICATIONS	J - 3
STRUCTURAL VIEW	J - 3
POWERFLOW	J - 4
TROUBLESHOOTING GUIDE	J - 5
TRANSMISSION OIL	J - 6
INSPECTION	J - 6
REPLACEMENT	J - 6
OIL SEAL (EXTENSION HOUSING)	J - 7
PREPARATION	J - 7
ON-VEHICLE REPLACEMENT	J - 7
TRANSMISSION	J - 8
PREPARATION	J - 8
REMOVAL	J -10
DISASSEMBLY	J -14
INSPECTION	J -31
ASSEMBLY	J -35
INSTALLATION	J -57
SHIFT MECHANISM	J -61
OVERHAUL	J -61

INDEX

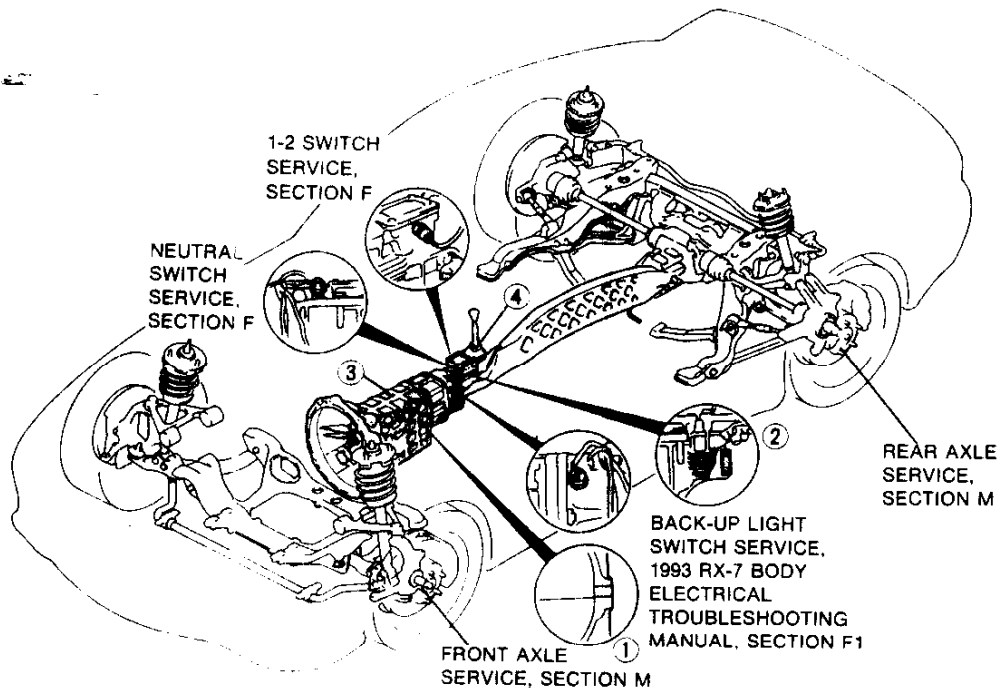

OIL SPECIFICATION

GRADE : API SERVICE GL-4 OR GL-5
 ALL SEASON : SAE 75W-90
 ABOVE 10°C (50°F) : SAE 80W-90
 CAPACITY : 2.5 L {2.6 US qts, 2.2 Imp qts}

37U0JX-002

- | | | |
|--|--|---|
| <p>1. Transmission oil
 Inspection page J-6
 Replacement page J-6</p> <p>2. Oil seal (extension housing)
 On-vehicle
 replacement page J-7</p> | <p>3. Transmission
 Removal page J-10
 Disassembly page J-14
 Inspection page J-31
 Assembly page J-35
 Installation page J-57</p> | <p>4. Shift mechanism
 Overhaul page J-61</p> |
|--|--|---|

OUTLINE

SPECIFICATIONS

Item		Model	R15M-D (R5M-D)
Synchronization mechanism			Forward: Synchromesh Reverse: Synchromesh
Shift type			5-speed, floor shift
Shift pattern			
Gear ratio	1st		3.483
	2nd		2.015
	3rd		1.391
	4th		1.000
	5th		0.719
	Reverse		3.288
Oil	Grade		API service GL-4 or GL-5
	Viscosity	All-season	SAE 75W-90
		Above 10°C (50°F)	SAE 80W-90
	Capacity	L {US qts, Imp qts}	2.5 {2.6, 2.2}

37U0JX-003

STRUCTURAL VIEW

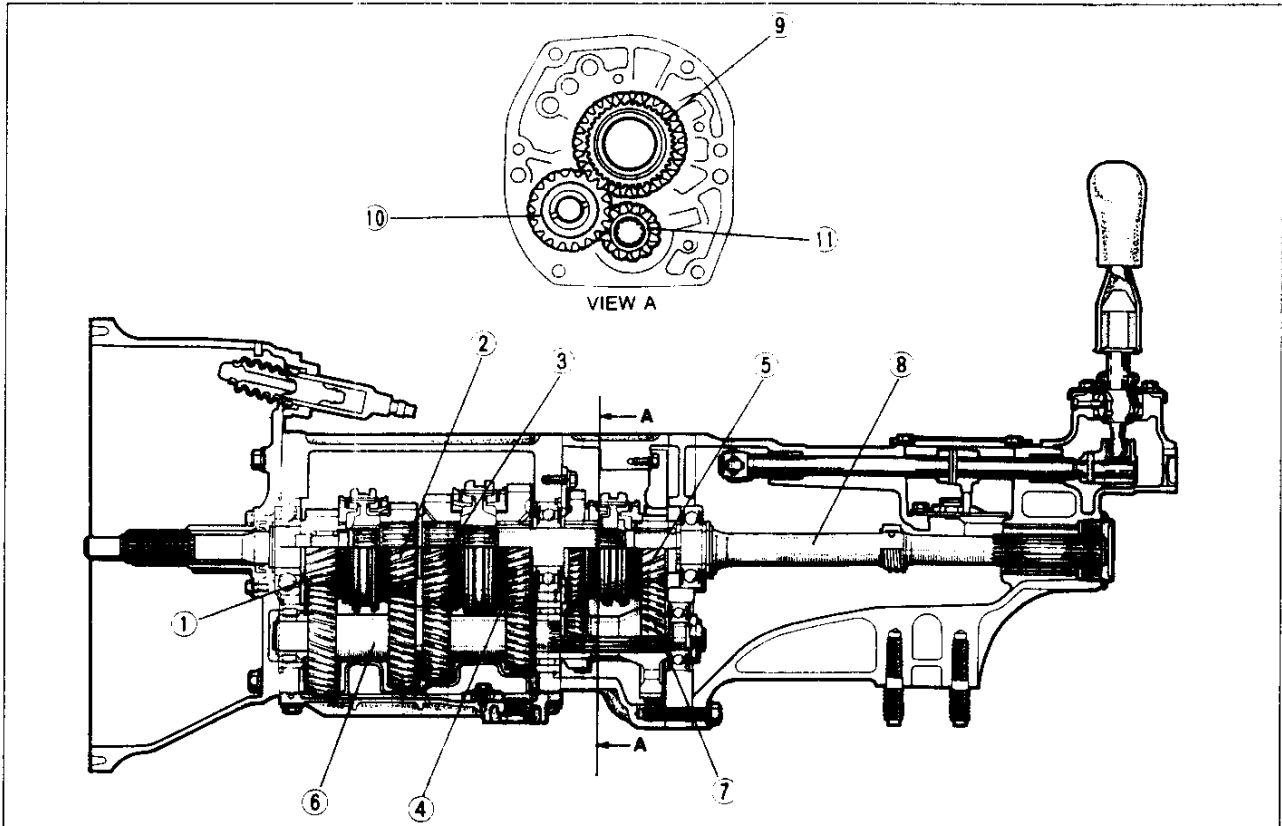

37U0JX-004

- | | |
|-------------------------------|--------------------------|
| 1. Main drive gear (4th gear) | 7. Counter 5th gear |
| 2. 3rd gear | 8. Mainshaft |
| 3. 2nd gear | 9. Reverse gear |
| 4. 1st gear | 10. Reverse idler gear |
| 5. 5th gear | 11. Counter reverse gear |
| 6. Countershaft | |

POWERFLOW

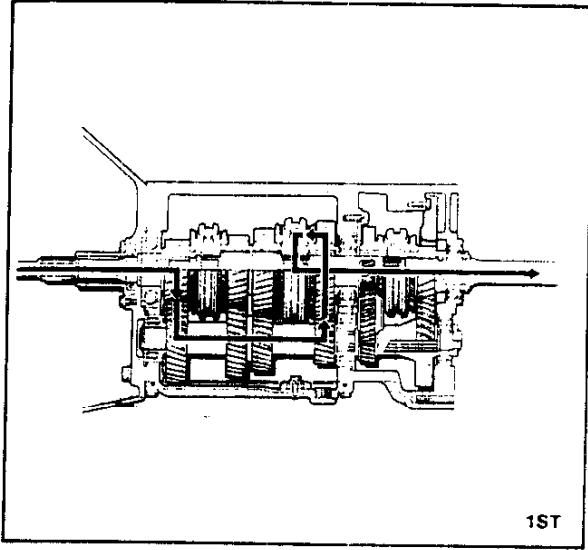

1ST

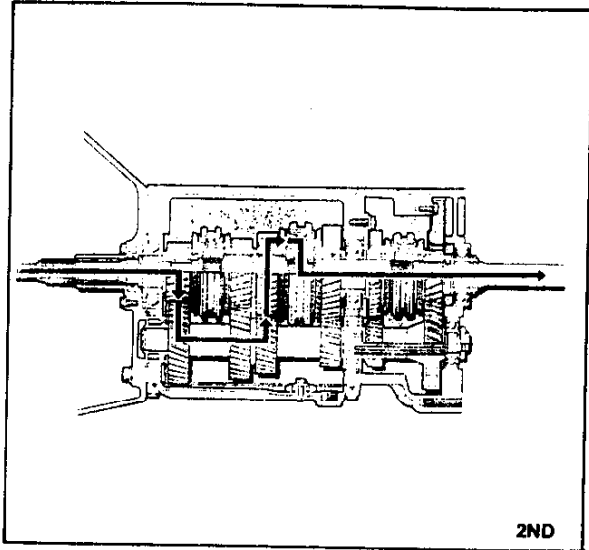

2ND

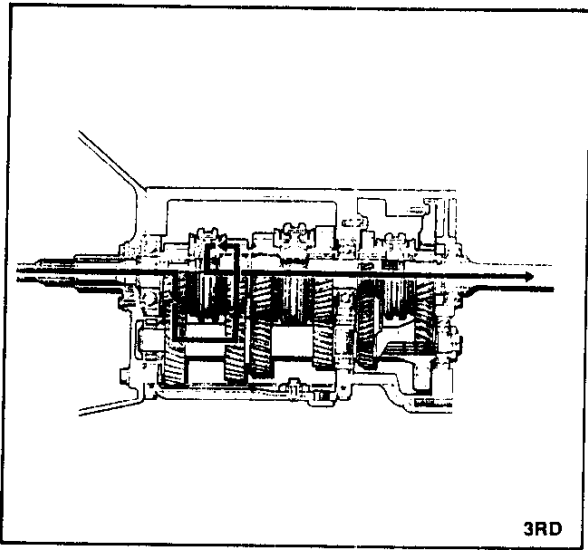

3RD

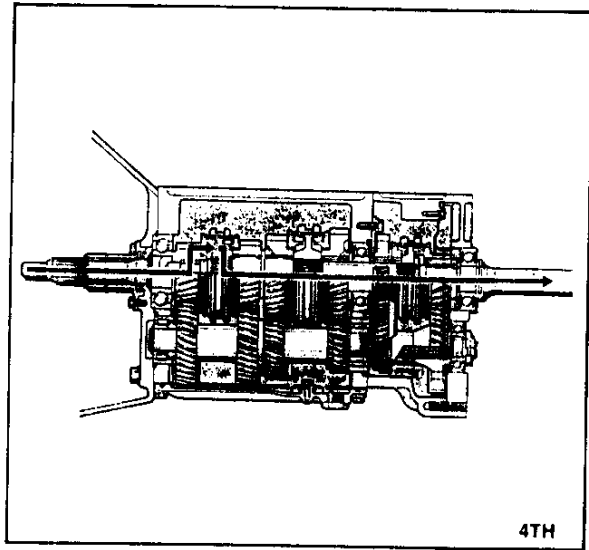

4TH

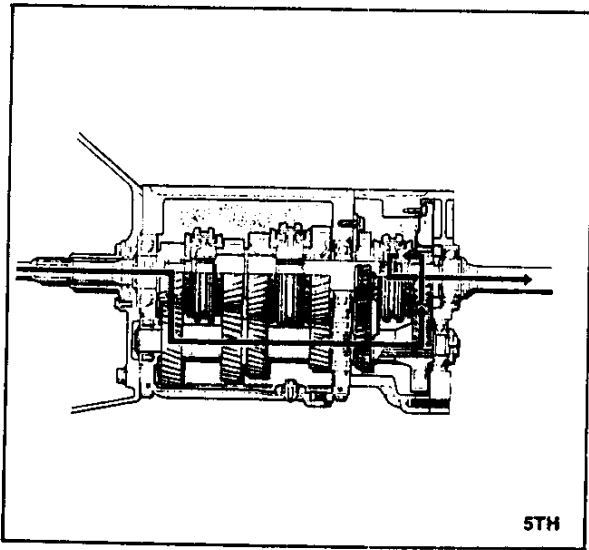

5TH

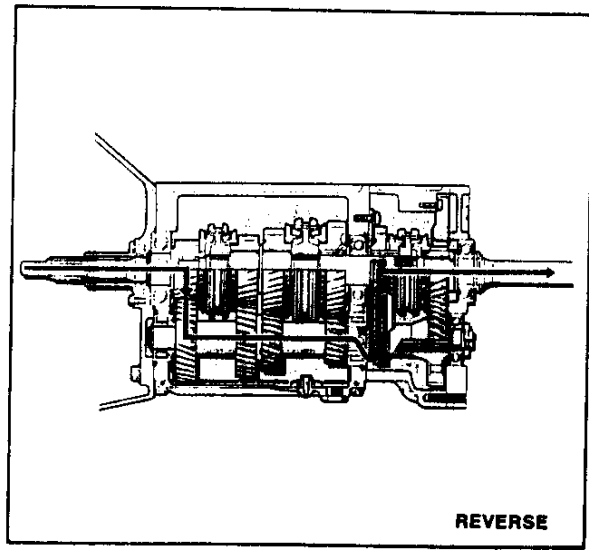

REVERSE

TROUBLESHOOTING GUIDE

Problem	Possible Cause	Action	Page
Abnormal noise	Insufficient oil	Add oil	J-6
	Deterioration of oil quality	Replace with specified oil	J-6
	Worn bearing	Replace	-
	Worn contact surface of countershaft gear	Replace	J-26
	Worn contact surface of gears	Replace	J-18, 22, 26
	Excessive gear backlash	Replace	J-18, 22, 26
	Damaged gear teeth	Replace	J-18, 22, 26
	Object caught in gears	Repair or replace	J-18, 22, 26
Difficult to shift	Bent shift rod	Replace	J-18
	Insufficient oil	Add oil	J-6
	Deterioration of oil quality	Replace with specified oil	J-6
	Wear or play of shift fork or shift rod	Replace	J-18, 22
	Worn or damaged synchronizer ring (1st, 4th, 5th, Reverse)	Replace	J-18, 26
	Worn or damaged synchronizer assembly (2nd and 3rd)	Replace	J-26
	Worn synchronizer gear cone	Replace	J-18, 22, 26
	Poor contact of synchronizer ring and gear cone	Replace	J-18, 22, 26
	Excessive longitudinal play of gears	Replace	J-18, 22, 26
	Worn bearing	Replace	-
	Improper disengagement of clutch	Refer to section H	-
Weak synchronizer key spring	Replace	J-18, 26	
Jumps out of gear	Weak detent ball spring	Replace	J-18
	Worn shift fork	Replace	J-18, 22
	Worn clutch hub	Replace	J-18, 26
	Worn clutch hub sleeve	Replace	J-18, 26
	Worn gears	Replace	J-18, 22, 26
	Excessive gear backlash	Replace	J-18, 22, 26
	Worn bearing	Replace	-
	Loose engine mounts or transmission mounts	Tighten	-

37U0JX-006

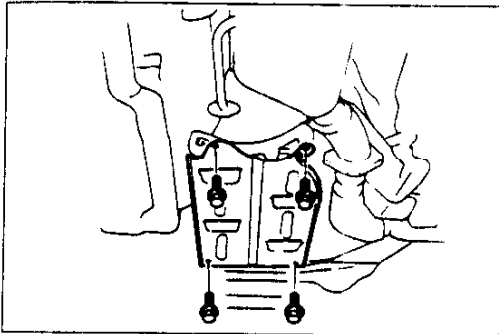

37U0JX-007

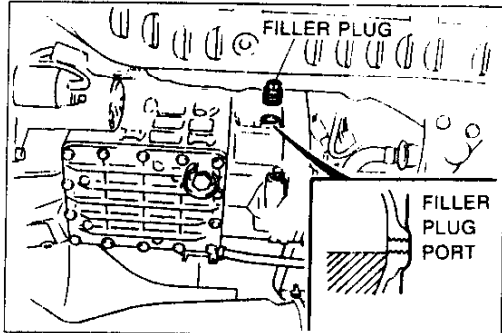

37U0JX-008

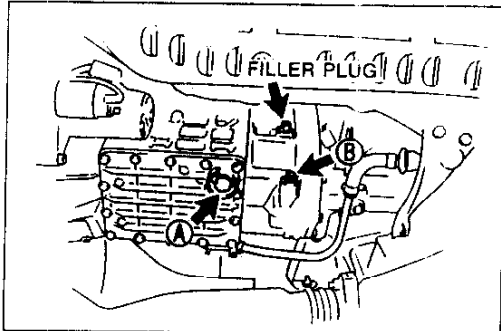

37U0JX-009

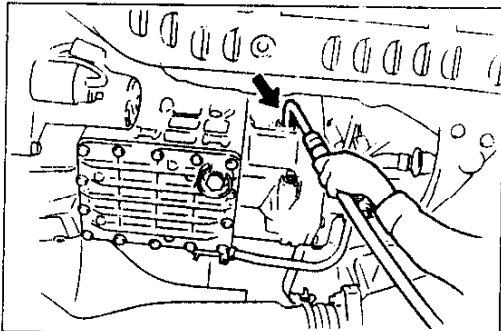

37U0JX-010

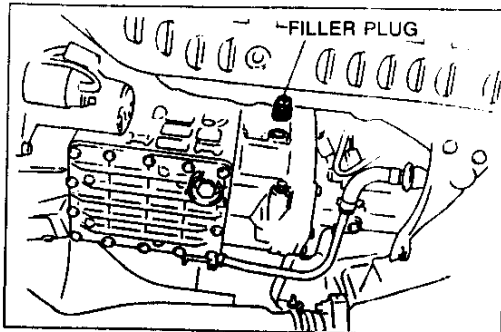

37U0JX-011

TRANSMISSION OIL INSPECTION

Caution

- Park the vehicle on level ground.

1. Remove the transmission cover.
2. Remove the filler plug.
3. Verify that the oil is up to the bottom of the filler plug hole.
4. If the oil level is low, add the specified oil through the filler plug port.
5. Install a new filler plug.

Tightening torque:

25–39 N·m {2.5–4.0 kgf·m, 19–28 ft·lbf}

6. Install the transmission cover.

Tightening torque:

7.9–10.7 N·m {80–110 kgf·cm, 70–95.4 in·lbf}

REPLACEMENT

1. Remove the transmission cover.
2. Remove plug A (with washer) and B, and drain the oil into a suitable container.
3. Wipe both plugs clean.
4. Apply sealant to the B plug threads.
5. Install plug A (with new washer) and B.

Tightening torque:

A: 40–58 N·m {4.0–6.0 kgf·m, 29–43 ft·lbf}

B: 21–31 N·m {2.1–3.2 kgf·m, 16–23 ft·lbf}

6. Remove the filler plug and add the specified oil through the filler plug port until the level rises to the bottom of the port.

Specified oil:

Grade: API service GL-4 or GL-5

All-season: SAE 75W-90

Above 10°C {50°F}: SAE 80W-90

Capacity: 2.5 L {2.6 US qts, 2.2 Imp qts}

7. Install a new filler plug.

Tightening torque:

25–39 N·m {2.5–4.0 kgf·m, 19–28 ft·lbf}



8. Install the transmission cover.

Tightening torque:

7.9–10.7 N·m {80–110 kgf·cm, 70–95.4 in·lbf}

OIL SEAL (EXTENSION HOUSING)

PREPARATION
SST

<p>49 G030 795</p> <p>Installer, oil seal</p> 	<p>For ir stallation of oil seal</p>	<p>49 G030 796</p> <p>Body (Part of 49 G030 795)</p> 	<p>For ir stallation of oil seal</p>
<p>49 G030 797</p> <p>Handle (Part of 49 G030 795)</p> 	<p>For ir stallation of oil seal</p>		

37U0JX 012

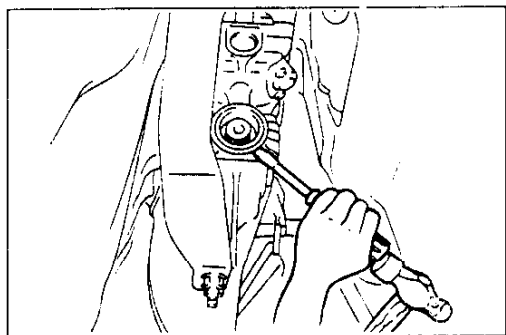

37U0JX-C13

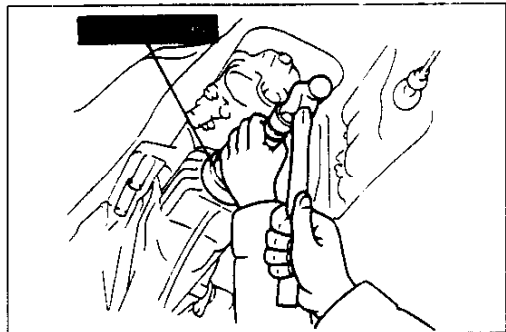

37U0JX-C14

ON-VEHICLE REPLACEMENT

Caution

- Do not damage the extension housing or mainshaft splines.

1. Remove the transmission cover.
2. Remove the propeller shaft. (Refer to section L.)
3. Remove the oil seal with a screwdriver.
4. Apply the specified oil to the new oil seal.
5. Install the oil seal by using the **SST**.
6. Install the propeller shaft. (Refer to section L.)
7. Inspect the oil level. (Refer to page J-6)
8. Install the transmission cover.







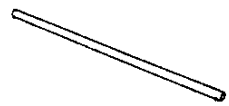

Tightening torque:

7.9-10.7 N·m {80-110 kgf·cm, 70-95.4 in·lbf}

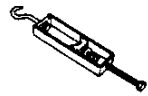
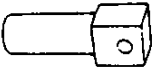
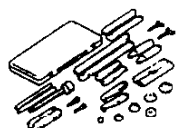
TRANSMISSION

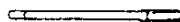
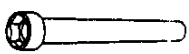
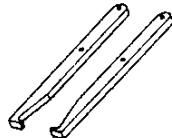
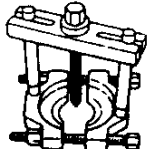
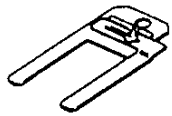

PREPARATION

SST

<p>49 G017 5A0 Support. engine</p> 	<p>For support of engine</p>	<p>49 G017 501 Bar (Part of 49 G017 5A0)</p> 	<p>For support of engine</p>
<p>49 G017 502 Support (Part of 49 G017 5A0)</p> 	<p>For support of engine</p>	<p>49 G017 503 Hook (Part of 49 G017 5A0)</p> 	<p>For support of engine</p>
<p>49 S120 440 Holder, mainshaft</p> 	<p>For holding mainshaft</p>	<p>49 0839 425C Puller set, bearing</p> 	<p>For removal of bearing</p>
<p>49 G030 795 Installer, oil seal</p> 	<p>For installation of oil seal</p>	<p>49 G030 796 Body (Part of 49 G030 795)</p> 	<p>For installation of oil seal</p>
<p>49 G030 797 Handle (Part of 49 G030 795)</p> 	<p>For installation of oil seal</p>	<p>49 0500 330 Installer, transmission bearing</p> 	<p>For installation of bearing</p>
<p>49 0636 145 Puller, fan pulley boss</p> 	<p>For removal of clutch hub assembly</p>	<p>49 0862 350 Guide, shift fork</p> 	<p>For installation of interlock pin</p>
<p>49 1243 465A Wrench, mainshaft locknut</p> 	<p>For removal of locknut</p>	<p>49 H017 101 Hook</p> 	<p>For removal of bearing</p>
<p>49 0710 520 Puller, bearing</p> 	<p>For removal of bearing</p>	<p>49 F017 101 Holder, synchronizer ring</p> 	<p>For installation of bearing</p>

TRANSMISSION

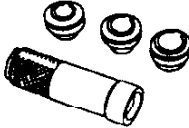
J

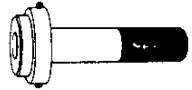
<p>49 F401 330B Installer set, bearing</p> 	<p>For installation of bearing</p>	<p>49 F401 331 Body (Part of 49 F401 330B)</p> 	<p>For installation of clutch hub assembly</p>
<p>49 F401 335A Attachment A (Part of 49 F401 330B)</p> 	<p>For installation of bearing race</p>	<p>49 0813 235 Replacer, main bearing</p> 	<p>For installation of main bearing</p>

37U0JX-015

REMOVAL

Caution

● **Remove the clutch release collar from the clutch cover before removing transmission.**

1. Disconnect the negative battery cable.
2. Remove in the order shown in the figure, referring to **Removal Note**.

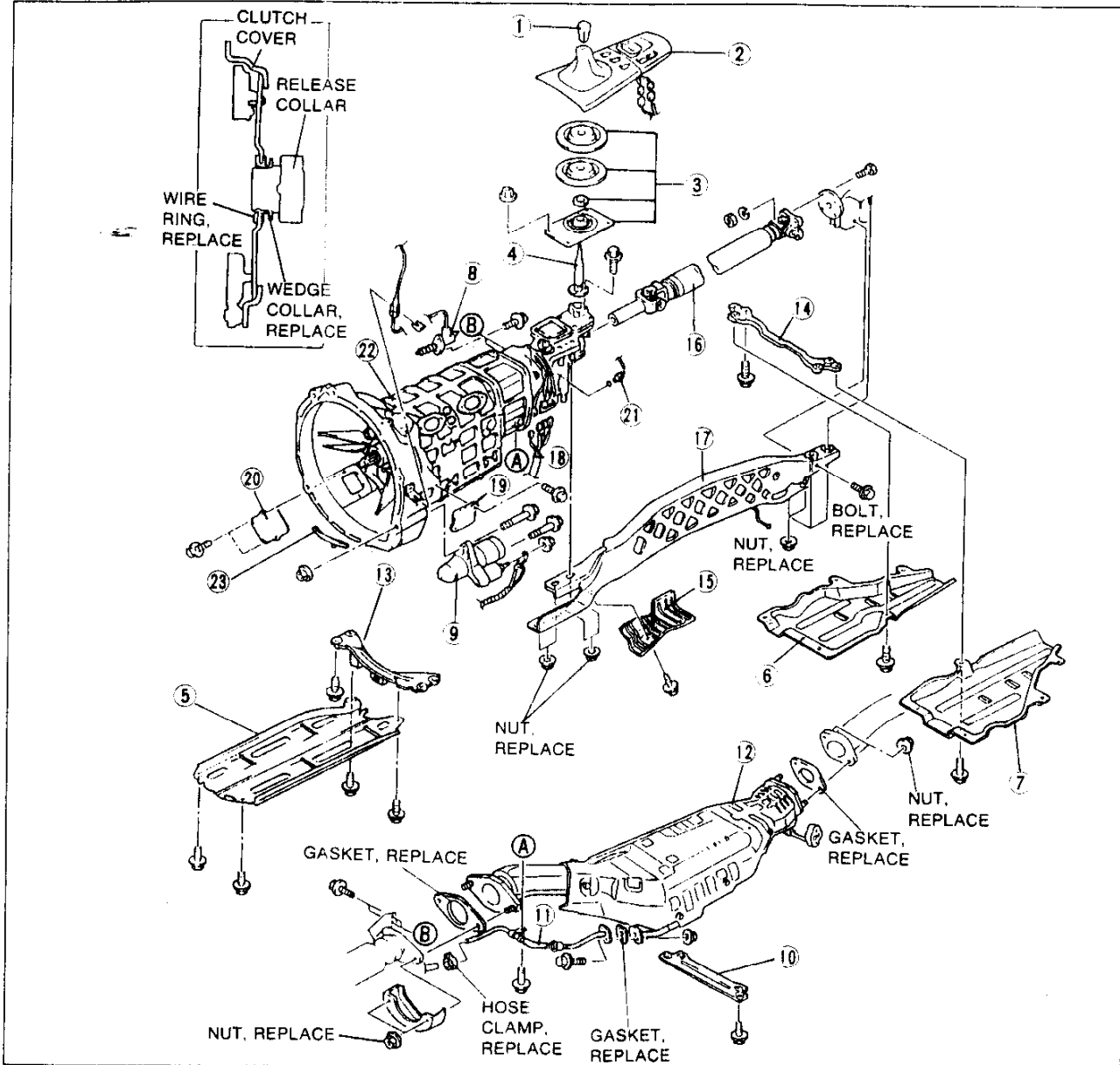

37U0JX-016

- | | | |
|--|--|---|
| <ol style="list-style-type: none"> 1. Shift lever knob 2. Console panel assembly 3. Insulator assembly 4. Shift lever assembly 5. Transmission cover 6. Right undercover 7. Left undercover 8. Clutch release cylinder
Removal Note
..... page J-11 9. Starter 10. Tunnel reinforcement
(center) | <ol style="list-style-type: none"> 11. Secondary air injection pipe 12. Catalytic converter assembly 13. Tunnel reinforcement (front) 14. Tunnel reinforcement (rear) 15. Cover 16. Propeller shaft
Removal Note
..... page J-11 | <ol style="list-style-type: none"> 17. Power Plant Frame (PPF)
Removal Note
..... page J-11 18. Connectors 19. Service hole A cover 20. Service hole B cover 21. Back-up light switch 22. Transmission
Removal Note
..... page J-12 23. Dust cover |
|--|--|---|

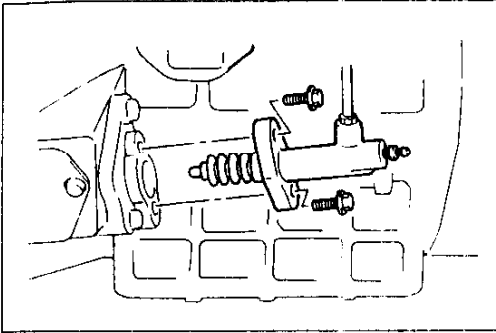

37U0JX 017

Removal Note Clutch release cylinder

Caution

- Do not damage the clutch pipe.

1. Loosen the clutch release cylinder installation bolts.
2. Loosen the clutch pipe bracket bolt.
3. Secure the clutch release cylinder/clutch pipe assembly in a place where it will not interfere with transmission removal.

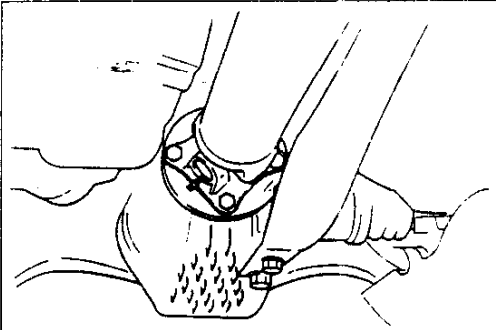

37U0JX 018

Propeller shaft

1. Mark the flanges for correct reinstallation.
2. Remove the propeller shaft.



49 S120 440

37U0JX 019

3. Install the **SST** to the extension housing.

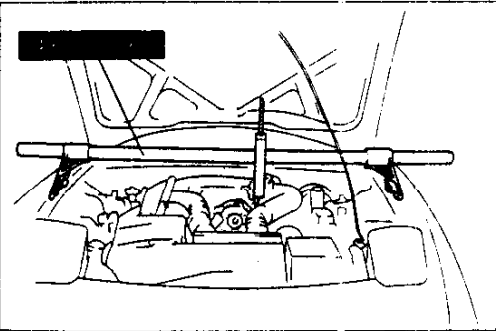

37U0JX 020

Power plant frame (PPF)

1. Hold the engine by using the **SST** (engine supports).

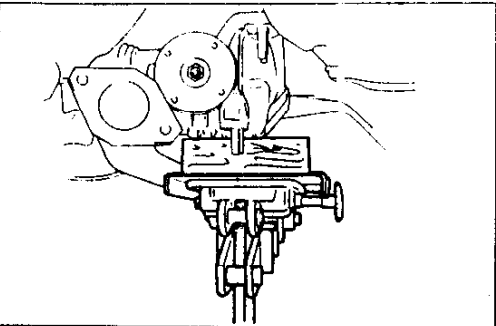

37U0JX-021

2. Hold the differential with a transmission jack.
3. Remove the PPF.
4. Remove the back-up light switch from the transmission.

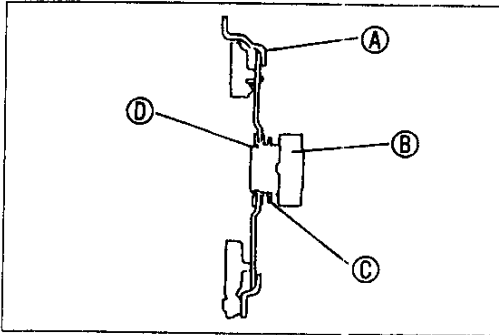

37U0JX-022

Transmission

1. The clutch cover and clutch release collar are joined as shown in the figure.

- A: Clutch cover
- B: Clutch release collar
- C: Wedge collar
- D: Wire ring

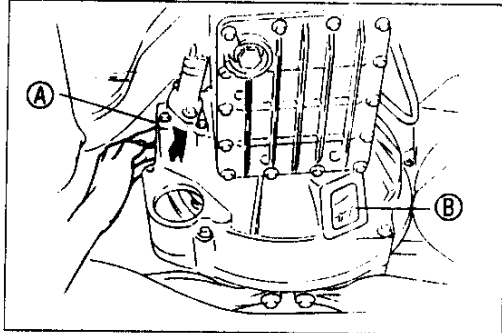

37U0JX-023

Caution

- Separation of the clutch cover and release collar must be done with the release collar pushed into the clutch cover, away from the transmission.
- Do not reuse wedge collar or wire ring. (Refer to section H.)

2. Remove the covers from service holes A and B.
 3. Through service hole A, swing the release fork so that the release collar is pushed and held toward the clutch cover (engine side).

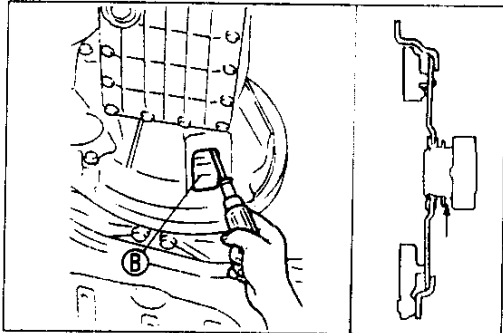

37U0JX-024

4. Insert a screwdriver through service hole B, into the space between the wedge collar and the release collar. Pry and separate the release collar from the clutch cover.

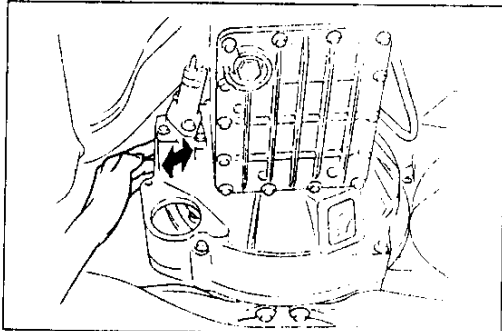

37U0JX-025

5. Swing the release fork back and forth to make sure that the release collar and clutch cover are separated.

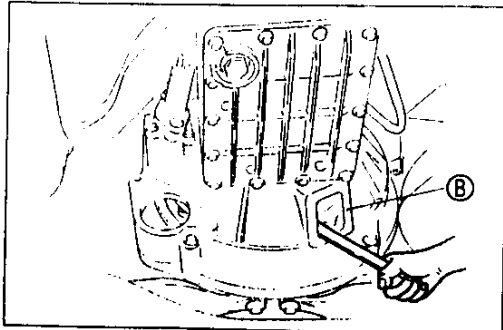

37U0JX-026

6. If the above procedure does not work, then separate the clutch cover from the flywheel, following the procedure below.

- (1) Through service hole B, gradually loosen the 6 clutch cover installation bolts in a crisscross pattern.
- (2) Remove the clutch cover installation bolts, and separate the clutch cover from the flywheel.

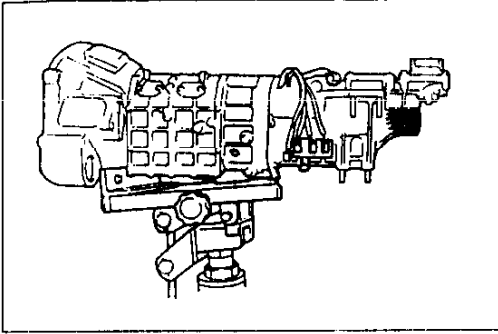

37U0JX-027

7. Support the transmission with a transmission jack.

Warning

- Do not allow the transmission to fall from the jack.

8. Loosen the transmission installation bolts.
9. Remove the transmission.

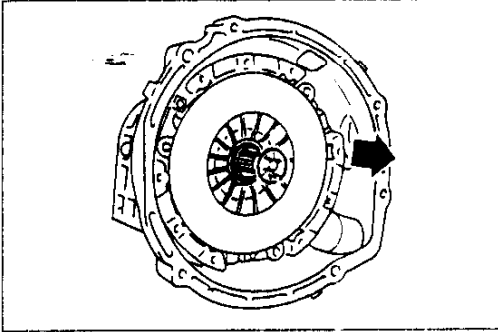

37U0JX-028

10. Remove the clutch cover.
 - (1) Remove the clutch cover from the flywheel.
(Refer to section H.)
 - (2) If the transmission was removed by following step 6, remove the wire ring from the release collar and separate the release collar from the clutch cover.

DISASSEMBLY**Precaution**

1. Clean the transmission exterior thoroughly with a steam cleaner or cleaning solvents before disassembly.
2. Clean the removed parts (except sealed bearings) with cleaning solvent, and dry with compressed air. Clean out all holes and passages with compressed air, and check that there are no obstructions.
3. Wear eye protection when using compressed air.
4. Use a plastic hammer when disassembling the transmission case and other light alloy metal parts.
5. Keep all disassembled parts in a clean area.
6. When using a vise, insert protective plates to prevent damage to the part.
7. Note the assembly position of each part as it is disassembled.
8. Inspect each part for damage while disassembling.

37U0JX-029

Clutch Housing and Extension Housing Components

Note

● Do not remove the front and rear oil seals unless necessary.

Disassemble in the order shown in the figure, referring to **Disassembly Note**.

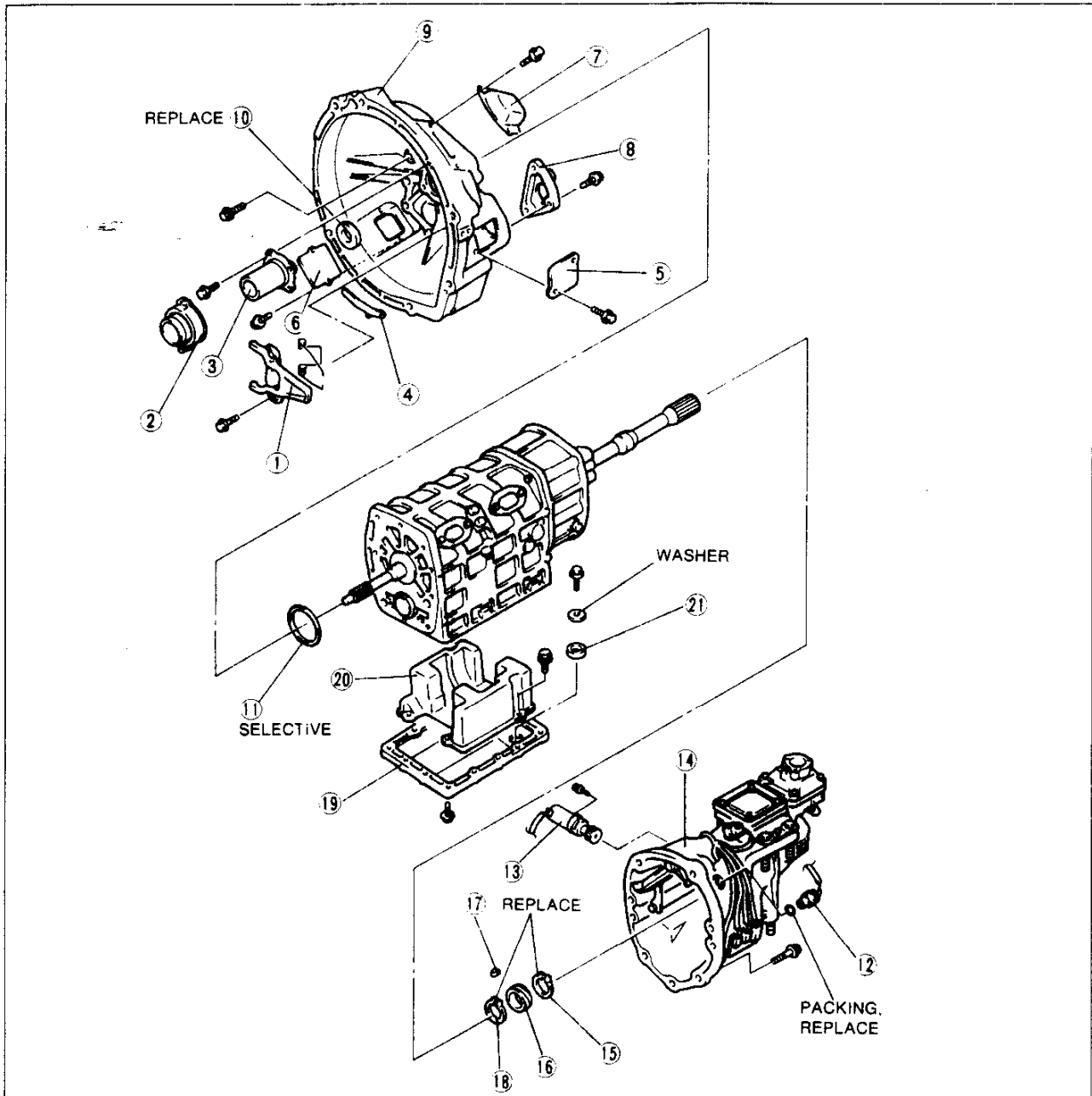

37U0JX-030

- | | | |
|-----------------------------|---|----------------------------|
| 1. Release fork assembly | 10. Oil seal (clutch housing) | 16. Speedometer drive gear |
| 2. Release collar | 11. Adjustment shim | 17. Key |
| 3. Front cover | 12. Back-up light switch | 18. Snap ring |
| 4. Dust cover | 13. Speedometer sensor
(Speedometer driven gear) | 19. Undercover |
| 5. Service hole A cover | 14. Extension housing | 20. Oil baffle |
| 6. Service hole B cover | Disassembly note | 21. Magnet |
| 7. Vent cover | page J-16 | |
| 8. Release cylinder support | 15. Snap ring | |
| 9. Clutch housing | | |

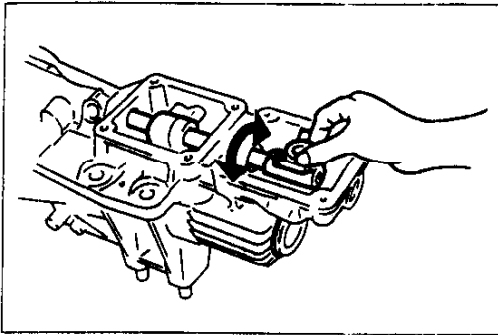

37JGJX-031

**Disassembly note
Extension housing**

1. Move the control rod end to the neutral position.
2. Remove the extension housing installation bolts.
3. Lift up on and remove the extension housing from the center housing.

MEMO

5th/Reverse Gear and Housing Components

Disassemble in the order shown in the figure, referring to **Disassembly Note**.

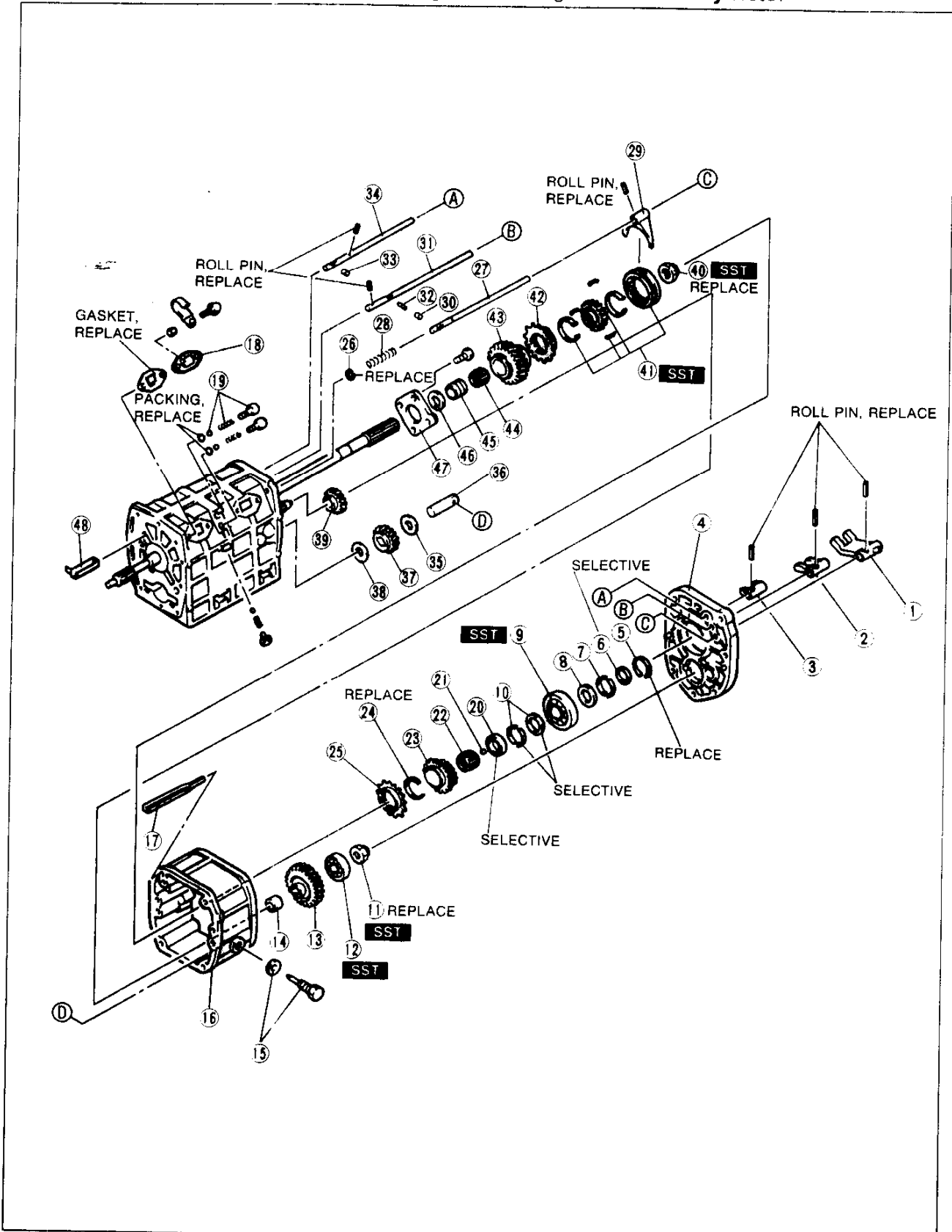

- | | | |
|--|--|---|
| <p>1. 5th/Reverse shift rod end
Inspection page J-32</p> <p>2. 3rd/4th shift rod end
Inspection page J-32</p> <p>3. 1st/2nd shift rod end
Inspection page J-32</p> <p>4. Bearing housing
Disassembly Note
..... below</p> <p>5. Snap ring</p> <p>6. Thrust washer</p> <p>7. C-washers</p> <p>8. Retaining ring</p> <p>9. Mainshaft rear bearing
Disassembly Note
..... below
Inspect for damage</p> <p>10. C-washers and retaining ring</p> <p>11. Locknut
Disassembly Note
..... page J-20</p> <p>12. Countershaft rear bearing
Disassembly Note
..... page J-20
Inspect for damage</p> <p>13. Counter 5th gear
Inspection page J-31</p> <p>14. Spacer</p> <p>15. Set bolt and washer</p> | <p>16. Center housing
Disassembly Note
..... page J-20</p> <p>17. Oil guide</p> <p>18. Blind cover</p> <p>19. Cap plug, spring, and detent ball</p> <p>20. Thrust lock washer</p> <p>21. Steel ball</p> <p>22. Bearing
Inspect for damage</p> <p>23. 5th gear
Inspection page J-31</p> <p>24. Retaining ring</p> <p>25. Synchronizer ring (5th)
Inspection page J-32</p> <p>26. Retaining ring</p> <p>27. 5th/Reverse shift rod
Disassembly Note
..... page J-20</p> <p>28. Spring
Inspection page J-33</p> <p>29. 5th/Reverse shift fork</p> <p>30. Interlock pin (large)</p> <p>31. 3rd/4th shift rod
Disassembly Note
..... page J-21</p> <p>32. Interlock pin (small)</p> <p>33. Interlock pin (large)</p> | <p>34. 1st/2nd shift rod
Disassembly Note
..... page J-21</p> <p>35. Thrust washer</p> <p>36. Reverse idler gear shaft
Inspection page J-33</p> <p>37. Reverse idler gear
Inspection page J-33</p> <p>38. Thrust washer</p> <p>39. Counter reverse gear
Inspection page J-31</p> <p>40. Locknut
Disassembly Note
..... page J-21</p> <p>41. 5th/Reverse clutch hub assembly
Disassembly Note
..... page J-21
Inspection page J-32</p> <p>42. Synchronizer ring (Reverse)
Inspection page J-32</p> <p>43. Reverse gear
Inspection page J-31</p> <p>44. Bearing
Inspect for damage</p> <p>45. Bearing race</p> <p>46. Thrust washer</p> <p>47. Bearing cover</p> <p>48. Oil guide</p> |
|--|--|---|

37U0JX-033

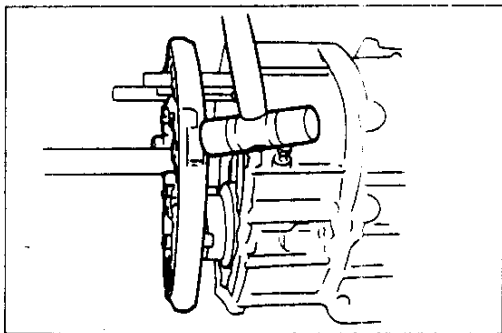

37U0.X-034

Disassembly note Bearing housing

Caution

- Using metal tools to remove the bearing housing could cause severe damage to its machined surfaces.

Hit down and outward on the bearing housing with a plastic hammer to remove.

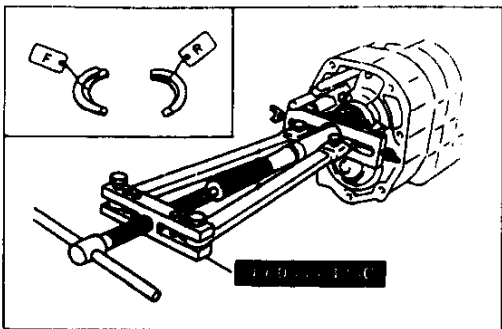

37U0JX-035

Mainshaft rear bearing

Caution

- The front and rear C-washers may have different thicknesses.

1. Remove the snap ring, washer, retaining ring, and rear C-washers.
2. Remove the mainshaft rear bearing by using the **SST**.
3. Remove the retaining ring and the front C-washers.

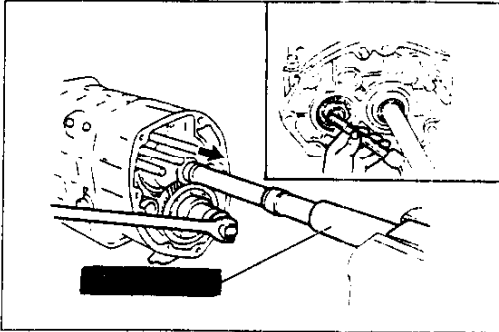

37U0JX-036

Locknut and countershaft rear bearing

1. Shift the 1st/2nd shift rod to 1st gear.

Caution

- Do not reuse the locknut.
- Do not scratch or damage the countershaft.

2. Uncrimp the tab of the locknut.
3. Hold the mainshaft by using the **SST** and a vise.
4. Remove the locknut.

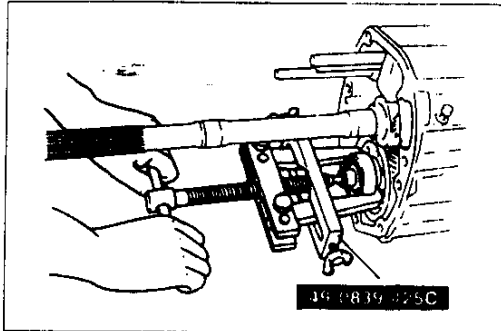

37U0JX-037

5. Remove the countershaft rear bearing by using the **SST**.

Center housing

1. Remove the set bolt and washer from the center housing.

Note

- If the center housing is difficult to remove, tap around the edge of the center housing with a plastic hammer.

2. Remove the center housing.

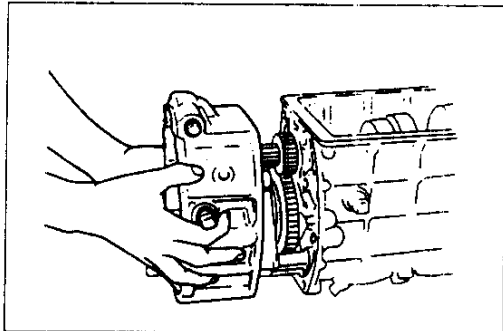

37U0JX-038

5th/Reverse shift rod

1. Remove the three cap plugs, packings, detent balls, and springs.

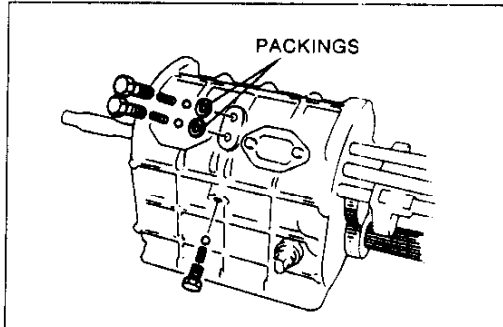

37U0JX-039

2. Drive the roll pin from the 5th/Reverse shift fork.

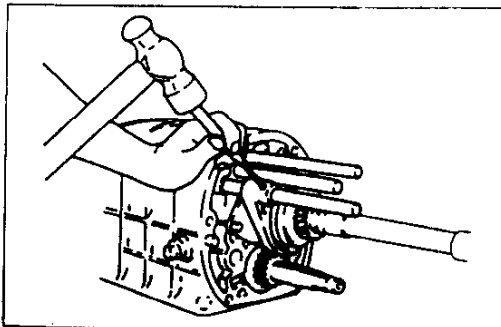

37U0JX-040

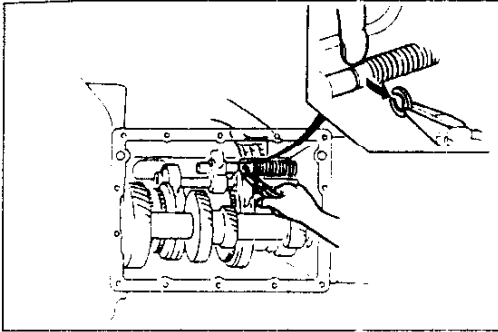

37U0JX-041

3. Pull the retaining ring from the 5th/Reverse shift rod.
4. Slide the 5th/Reverse shift rod out of the transmission case, and remove the spring.

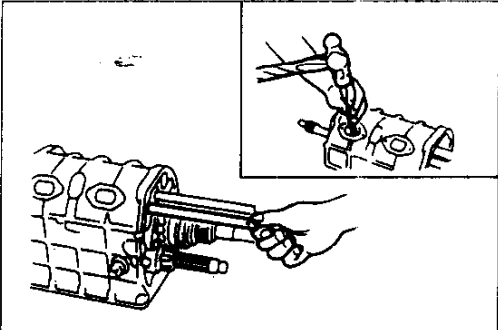

37U0JX-042

1st/2nd and 3rd/4th shift rods

1. Shift the transmission into 4th gear to gain access to the roll pin. Drive the roll pin from the 3rd/4th shift fork.
2. Slide the 3rd/4th shift rod and interlock pin (small) out from the rear of the transmission case.
3. Drive the roll pin from the 1st/2nd shift fork. Slide the 1st/2nd shift rod out from the rear of the transmission case, and remove the interlock pin (large).

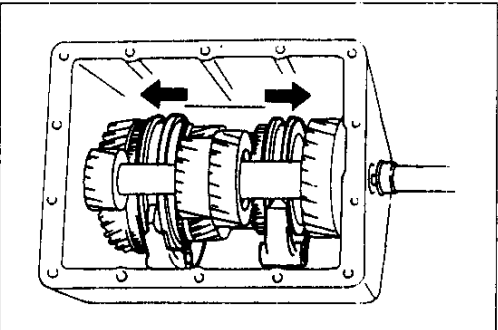

37U0JX-043

Locknut

1. Uncrimp the tab of the locknut.
2. Shift into 1st and 4th gears to lock the rotation of the mainshaft.

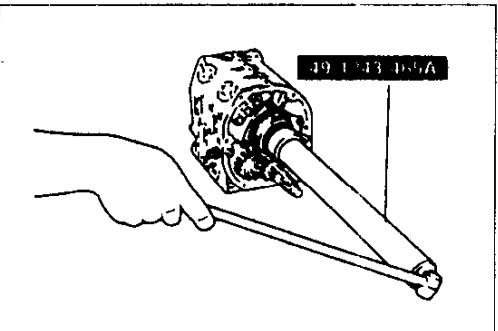

37U0JX-044

Caution

- Do not reuse the locknut.

3. Remove the locknut by using the **SST**.

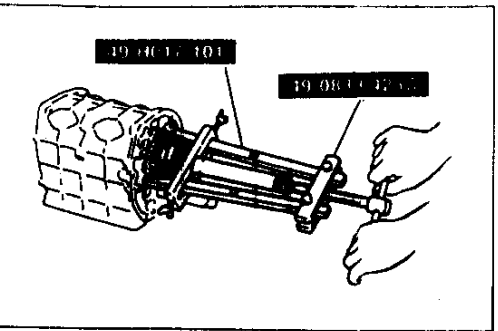

37U0JX-045

5th/Reverse clutch hub assembly

1. Remove the bearing cover installation bolts.
2. Attach the **SST** to the bearing cover and remove the assembly, which consists of the following parts:
 - 5th/Reverse clutch hub assembly
 - Synchronizer ring
 - Needle bearing
 - Bearing race
 - Reverse gear
 - Thrust washer

Transmission Case Components

Disassemble in the order shown in the figure, referring to **Disassembly Note**.

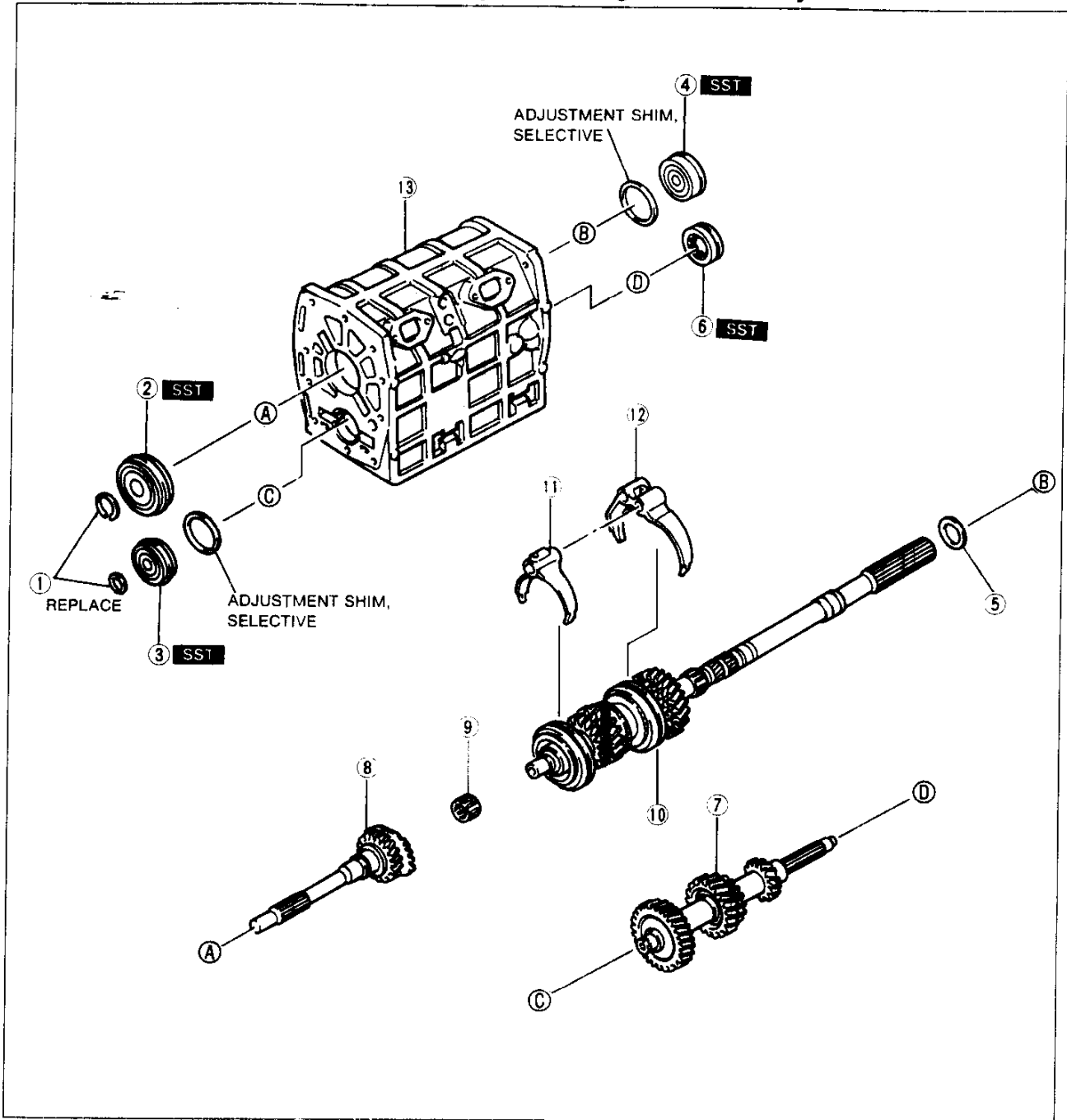

37U0JX-046

- 1. Snap rings
Disassembly Note
..... page J-23
- 2. Main drive gear bearing
Disassembly Note
..... page J-23
Inspect for damage
- 3. Countershaft front bearing
Disassembly Note
..... page J-23
Inspect for damage

- 4. Mainshaft front bearing
Disassembly Note
..... page J-24
Inspect for damage
- 5. Thrust washer
- 6. Countershaft center bearing
Disassembly Note
..... page J-24
Inspect for damage
- 7. Countershaft assembly

- 8. Main drive gear
Inspection page J-31
- 9. Bearing
- 10. Mainshaft gear assembly
Disassembly Note
..... page J-24
- 11. 3rd/4th shift fork
- 12. 1st/2nd shift fork
- 13. Transmission case

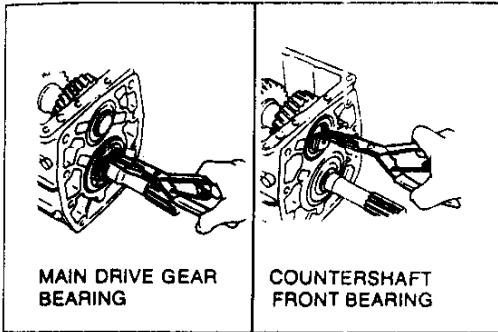

37U0JX-047

Disassembly note Snap rings

Caution

- Do not reuse the snap rings.

Remove the snap rings from the mainshaft and the countershaft by using snap ring pliers.

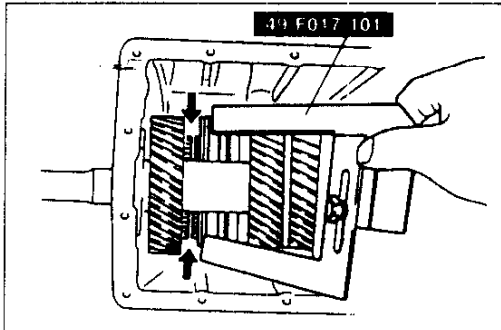

37U0JX-048

Main drive gear bearing

1. Install the **SST** between the 4th gear synchronizer ring and main drive synchromesh gear.

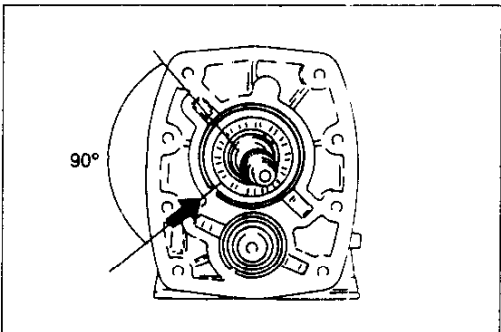

37U0JX-049

2. Turn the bearing snap rings so that the ends are 90° to the transmission case grooves.

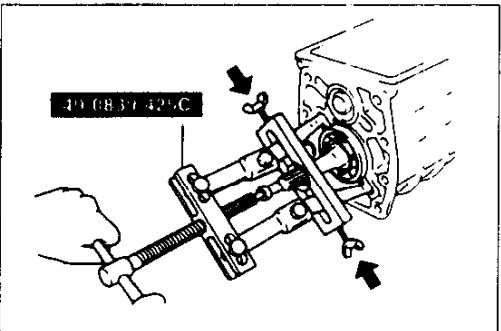

37U0JX-050

Caution

- Be extremely careful not to damage the bearing snap ring while using the SST (bearing puller).
- Tighten the SST side screws shown in the figure.

3. Remove the main drive gear bearing by using the **SST**.

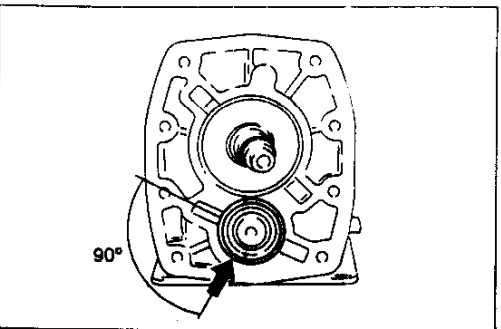

37U0JX-051

Countershaft front bearing

1. Turn the bearing snap rings so that the ends are 90° to the transmission case grooves.

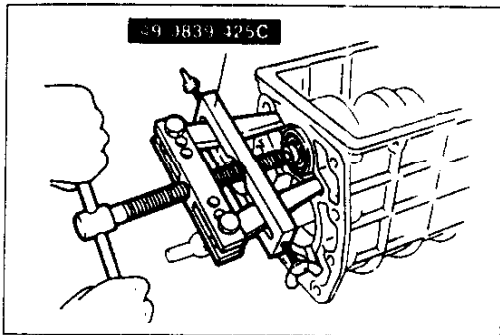

37U0JX-052

Note

- Replace the countershaft front bearing and countershaft front spacer as one assembly.

2. Remove the countershaft front bearing by using the **SST**.

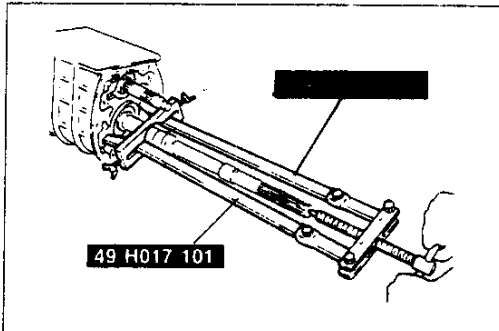

37U0JX-053

Mainshaft front bearing

Remove the mainshaft front bearing by using the **SST**.

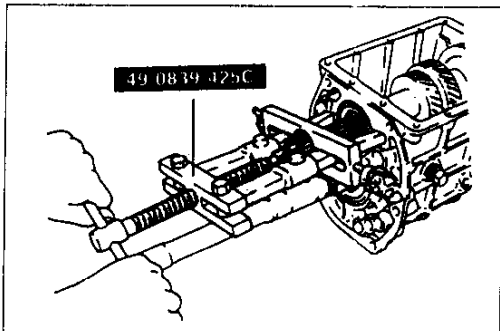

37U0JX-054

Countershaft center bearing

1. Remove the countershaft center bearing by using the **SST**.

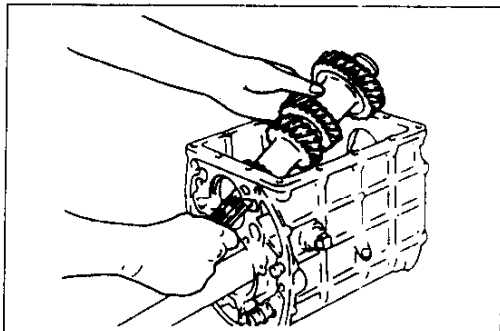

37U0JX-055

Caution

- Do not damage the transmission case or countershaft.

2. Remove the countershaft.

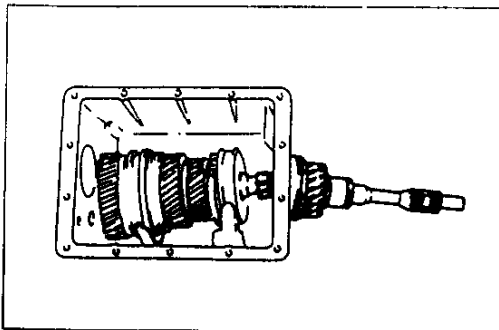

37U0JX-056

Mainshaft gear assembly

Caution

- Do not damage the main drive gear bearing bore.

1. Remove the main drive gear from the transmission case.
2. Remove the needle bearing from the mainshaft joint of the main drive gear.

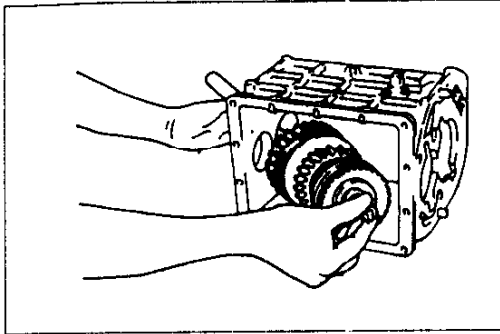

37U0JX-057

3. Remove the mainshaft gear assembly from the transmission case.

J

TRANSMISSION

Mainshaft and Countershaft Components

Caution

- Do not remove the countershaft center bearing race unless necessary.

Disassemble in the order shown, referring to **Disassembly Note**.

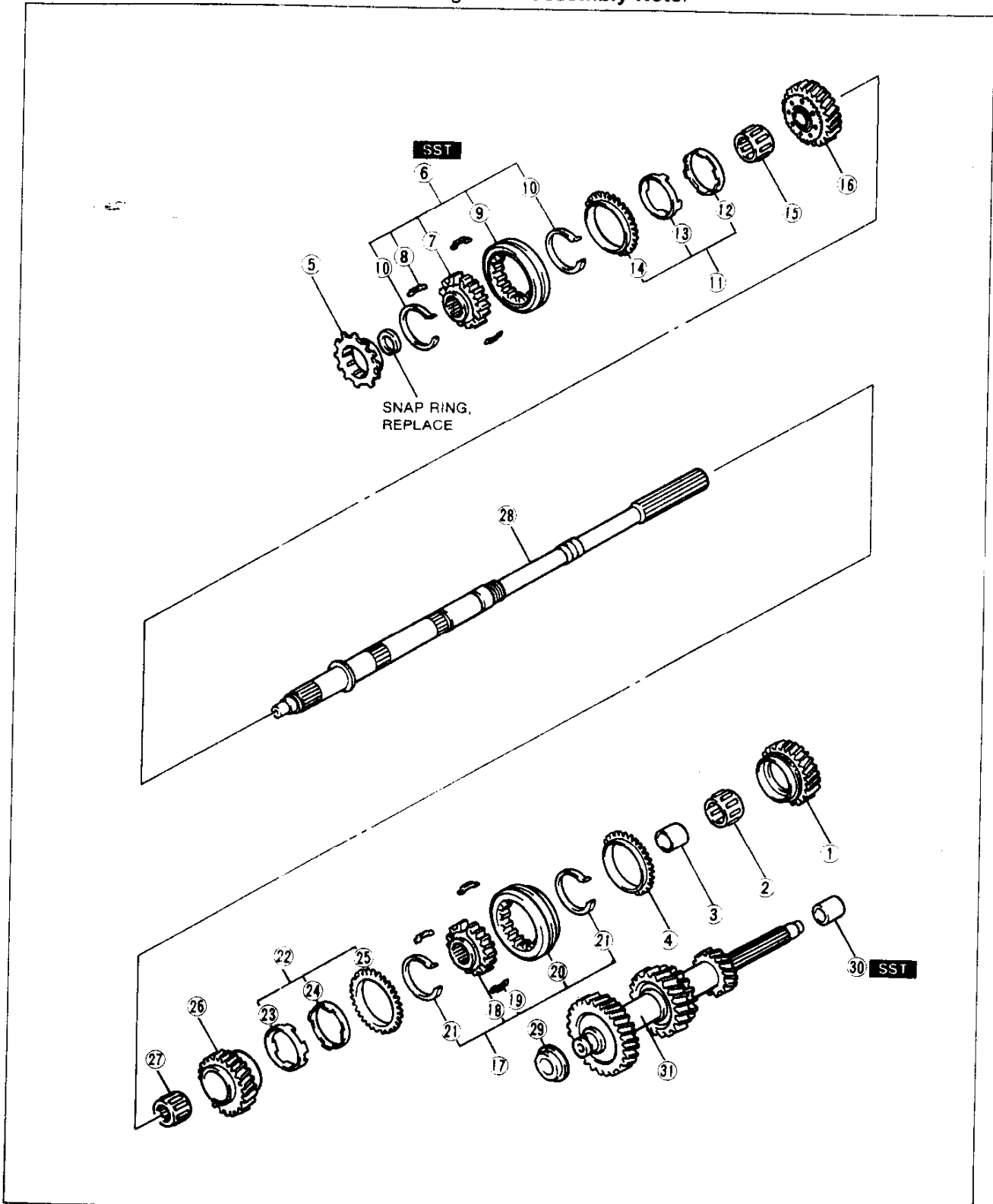

- | | | |
|--|---|--|
| 1. 1st gear
Inspection page J-31 | 12. Inner cone | 23. Inner cone |
| 2. Bearing
Inspect for damage | 13. Double cone | 24. Double cone |
| 3. Bearing race | 14. Synchronizer ring | 25. Synchronizer ring |
| 4. Synchronizer ring (1st)
Inspection page J-32 | 15. Bearing
Inspect for damage | 26. 2nd gear
Inspection page J-31 |
| 5. Synchronizer ring (4th)
Inspection page J-32 | 16. 3rd gear
Inspection page J-31 | 27. Bearing
Inspect for damage |
| 6. 3rd/4th clutch hub
assembly
Disassembly Note
..... below
Inspection page J-32 | 17. 1st/2nd clutch hub
assembly
Disassembly Note
..... below
Inspection page J-32 | 28. Mainshaft
Inspection page J-31 |
| 7. 3rd/4th clutch hub | 18. 1st/2nd clutch hub | 29. Countershaft front
bearing spacer |
| 8. Synchronizer key | 19. Synchronizer key | 30. Countershaft center
bearing race
Disassembly Note
..... page J-28 |
| 9. Clutch hub sleeve | 20. Clutch hub sleeve | 31. Countershaft
Inspection page J-31 |
| 10. Synchronizer key
spring (3rd/4th) | 21. Synchronizer key spring | |
| 11. Synchronizer assembly
(3rd)
Inspection page J-33 | 22. Synchronizer assembly
(2nd)
Inspection page J-33 | |

37U0JX-059

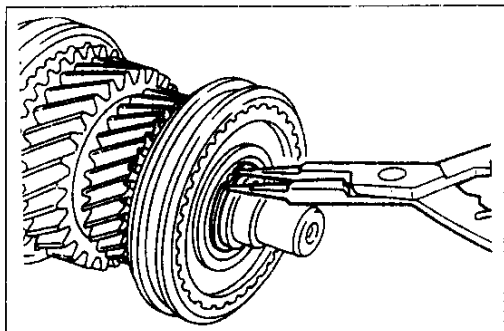

37U0JX-060

**Disassembly note
3rd/4th clutch hub assembly**

Caution

- Do not reuse the snap ring.

1. Remove the snap ring from the front of the mainshaft.

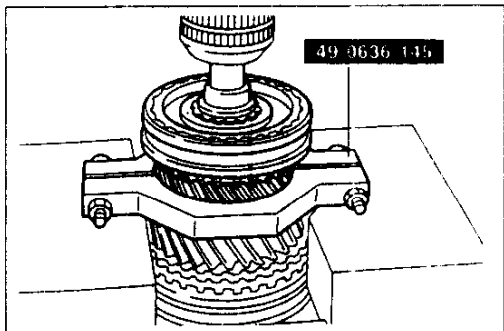

37JCJX-061

2. Position the SST between 2nd and 3rd gears.

Caution

- Hold the mainshaft with one hand so that it does not fall.

3. Press the mainshaft out from the 3rd gear, synchronizer ring assembly (3rd), and the 3rd/4th clutch hub assembly.

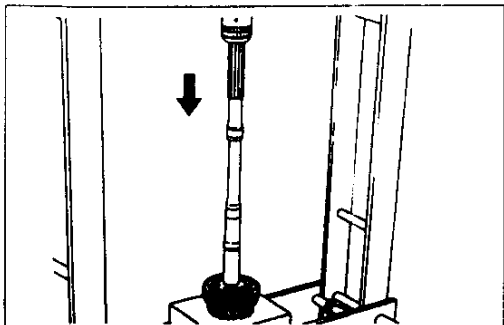

37U0JX-062

1st/2nd clutch hub assembly

Caution

- Hold the mainshaft with one hand so that it does not fall.

Press the 1st/2nd clutch hub assembly, synchronizer ring assembly (2nd), and 2nd gear from the mainshaft.

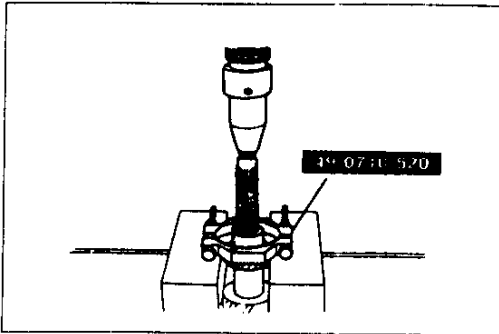

37L-0710-520

Countershaft center bearing race**Caution**

- Hold the countershaft with one hand so that it does not fall.

Note

- Replace the countershaft center bearing and bearing race as one assembly.

Remove the countershaft bearing race from the mainshaft by using the **SST**.

Extension Housing Components

Caution

● Do not remove the extension housing oil seal unless necessary.

Disassemble in the order shown, referring to **Disassembly Note**.

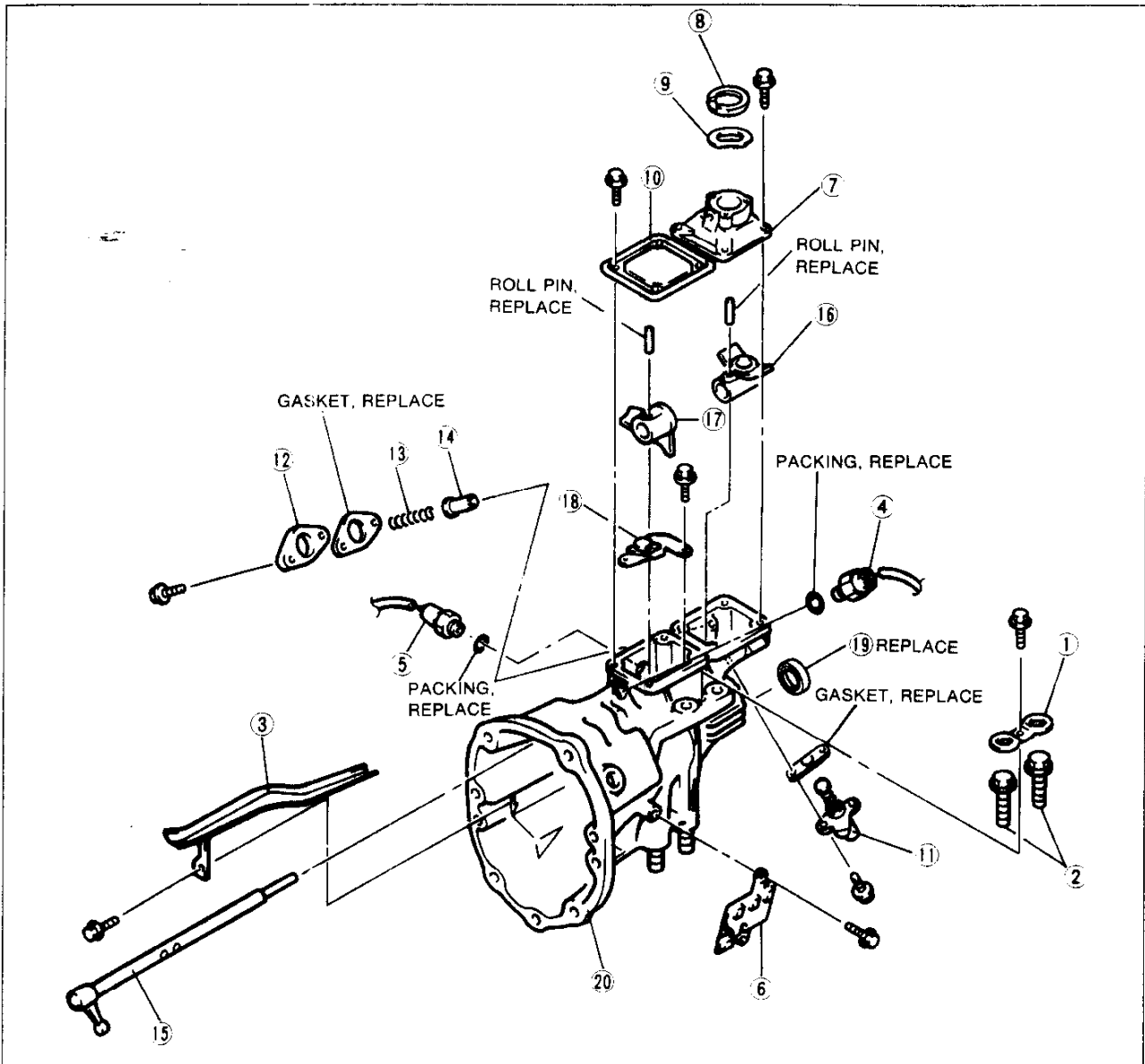

37U0JX-064

- | | | |
|---|--|---|
| <p>1. Stopper</p> <p>2. Power plant frame installation bolts</p> <p>3. Oil guide</p> <p>4. Neutral switch</p> <p>5. 1-2 switch</p> <p>6. Bracket</p> <p>7. Control case</p> <p>8. Bushing
Inspect for wear and damage</p> | <p>9. Wave washer
Inspect for wear and damage</p> <p>10. Blind cover</p> <p>11. Select spindle assembly</p> <p>12. Spring cap</p> <p>13. Select lock spindle spring
Inspection page J-33</p> <p>14. Select lock spindle</p> <p>15. Control rod
Disassembly Note
..... page J-30
Inspection page J-32</p> | <p>16. Control rod end</p> <p>17. Selector</p> <p>18. Shift guide assembly</p> <p>19. Oil seal
Disassembly Note
..... page J-30</p> <p>20. Extension housing
Inspection page J-34</p> |
|---|--|---|

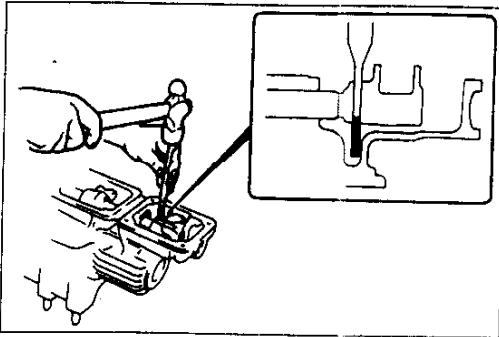

37U0JX-065

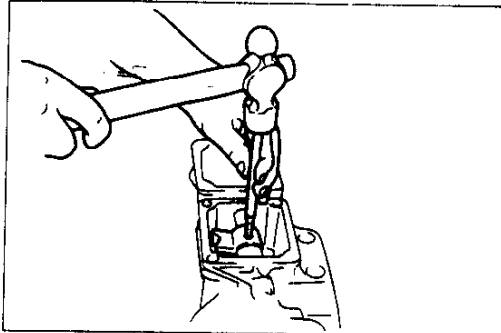

37U0JX-066

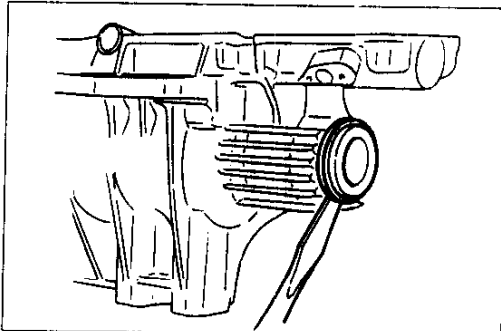

37U0IX-067

Disassembly note Control rod

1. Slide the control rod end to the point where the roll pin is directly above the recess in the extension housing.
2. Remove the roll pin from the control rod end by using a pin punch and hammer.
3. Remove the roll pin from the selector by using a pin punch and hammer.
4. Slide the control rod from the extension housing, and remove the control rod end and selector.

Oil seal (extension housing)

Caution

- **Do not scratch or damage the extension housing.**

Remove the oil seal from the extension housing by using a screwdriver.

INSPECTION

Inspect all parts, and repair or replace as necessary.

37U0JX-068

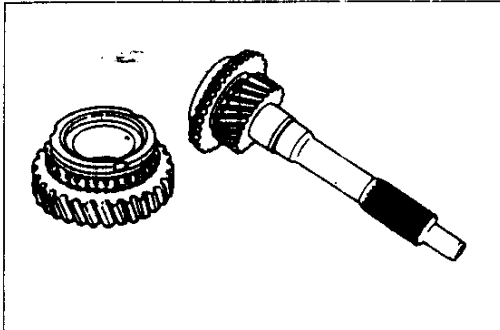

37U0JX-069

Each Gear and Main Drive Gear

1. Inspect synchronizer cones for wear.
2. Inspect individual gear teeth for damage, wear, and cracks.
3. Inspect synchronizer ring matching teeth for damage and wear.
4. Inspect main drive gear splines for damage and wear.

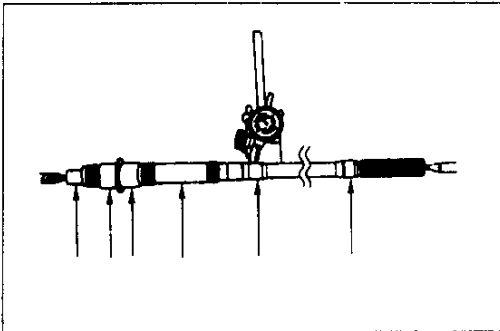

37U0JX-070

Mainshaft

1. Measure the mainshaft runout.
- Runout: 0.03 mm {0.0012 in} max.**
2. Inspect splines for damage and wear.

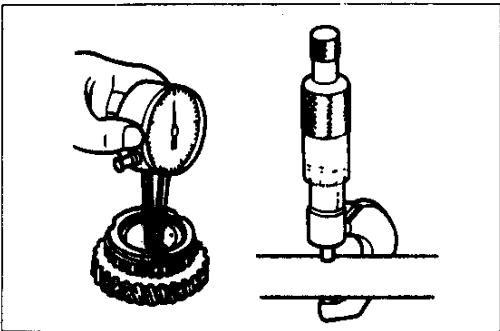

37U0JX-071

3. Measure the clearance between mainshaft and gear (or bushing).

Clearance: 0.15 mm {0.006 in} max.

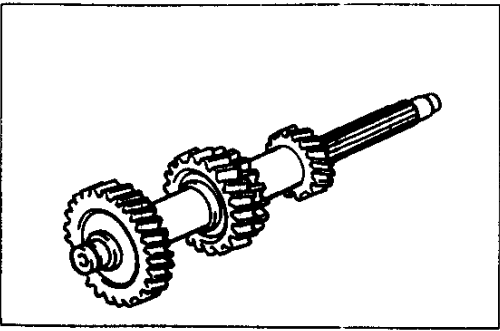

37U0JX-072

Countershaft

1. Inspect gear teeth for damage, wear, and cracks.
2. Inspect splines for damage and wear.

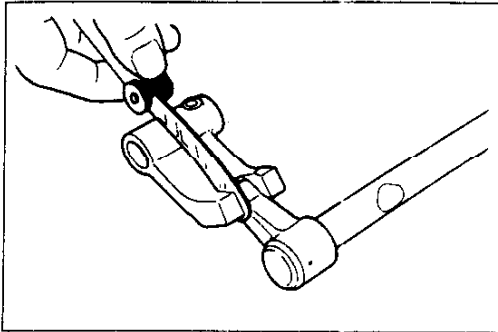

37U0JX-073

Control Rod Lever and Shift Rod

Measure the clearance between the control rod lever and the shift rod gate.

Clearance: 0.8 mm {0.031 in} max.

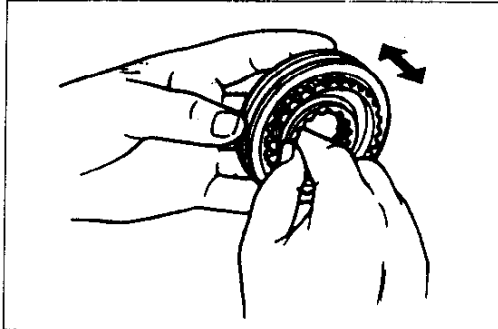

37U0JX-074

Each Clutch Hub Assembly

1. Inspect clutch hub sleeve and hub operation.
 2. Inspect individual gear teeth for damage, wear, and cracks.
 3. Inspect synchronizer keys for damage, wear, and cracks.
4. Measure the clearance between the hub sleeve groove and shift fork.

Clearance:

0.2–0.3 mm {0.008–0.012 in}

Maximum: 0.5 mm {0.020 in}

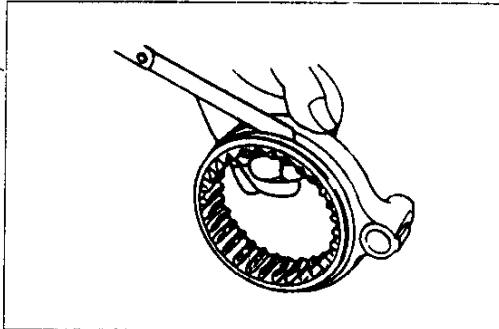

37U0JX-075

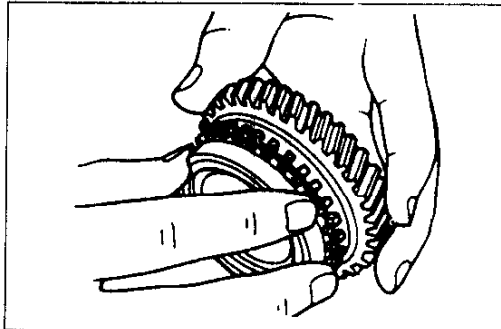

37U0JX-076

Synchronizer Ring (1st, 4th, 5th, Reverse)

1. Inspect individual synchronizer ring teeth for damage, wear, and cracks.
2. Inspect taper surface for wear and cracks.

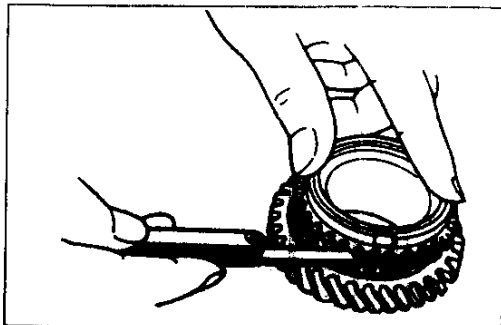

37U0JX-077

Note

- **Set the synchronizer ring squarely in the gear.**

3. Measure the clearance between the synchronizer ring and flank surface of gear.

Clearance: 1.5 mm {0.059 in}

Minimum: 0.8 mm {0.031 in}

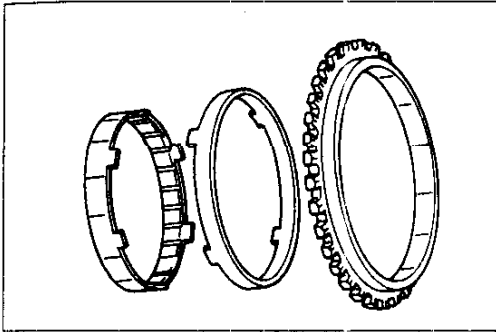

37U0JX-078

Synchronizer Assembly (2nd/3rd)

Caution

- If any part of the synchronizer assembly is damaged, replace the assembly as a whole.

1. Inspect individual synchronizer ring gear teeth for damage, wear, and cracks.
2. Inspect for wear and damage to the tapered surfaces of the inner cone, double cone, and synchronizer ring.

Note

- Set the synchronizer assembly squarely in the gear.

3. Measure the clearance between the synchronizer ring and flank surface of gear.

Clearance: 1.5 mm {0.059 in}
Minimum: 0.8 mm {0.031 in}

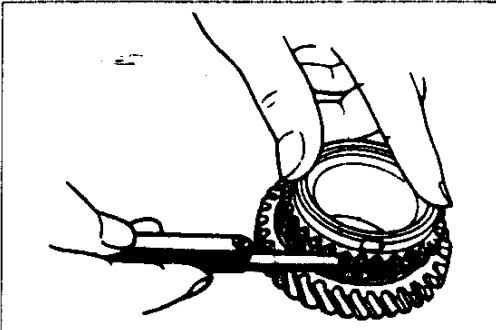

37U0JX-079

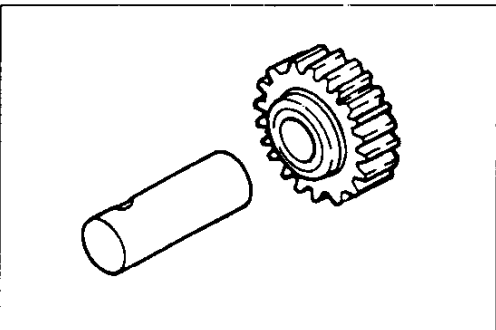

37J0JX-080

Reverse Idler Gear and Shaft

1. Inspect gear teeth for damage, wear, and cracks.

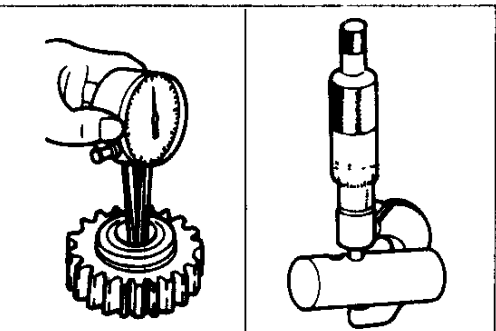

37U0JX-081

2. Measure the clearance between the reverse idler gear bushing and shaft.

Clearance:
0.02–0.05 mm {0.0008–0.0020 in}
Maximum: 0.15 mm {0.006 in}

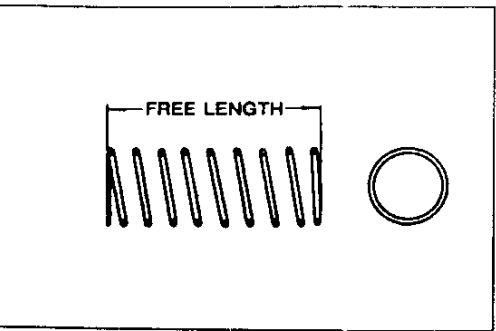

37U0JX-082

Spring

Measure the free length of the spring.

Standard free length: mm {in}
Detent ball spring: 22.5 {0.886}
5th/Reverse retaining spring: 73.00 {2.874}
Select lock spindle spring: 43.25 {1.703}

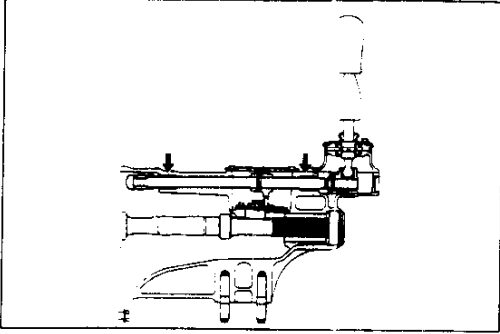

37U0JX-083

Extension Housing

1. Inspect the indicated bearings for damage.
2. Replace the extension housing if necessary.

ASSEMBLY

Precaution

1. Make sure each part is cleaned before assembling.
2. Coat all movable parts with the specified oil.
3. Replace parts wherever required.
4. Remove old sealant from contact surfaces before applying new sealant.
5. Assemble the parts within 10 minutes after applying sealant. Allow all sealant to cure at least 30 minutes after assembly before filling the transmission with transmission oil.
6. When using a vise, insert protective plates to prevent damage to the part.

37U0JX-084

Extension Housing Components

Assemble in the order shown, referring to **Assembly Note**.

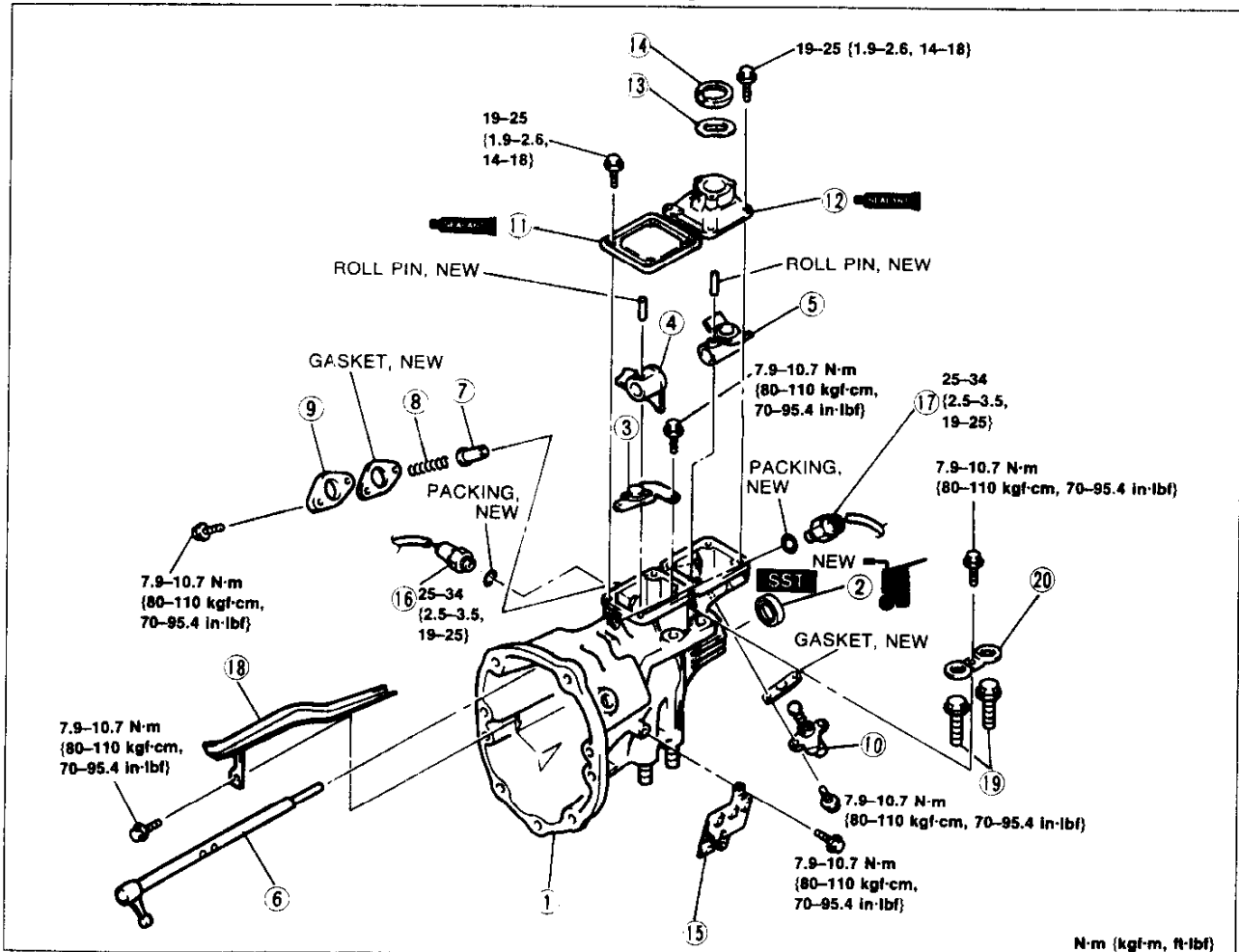

37U0JX-085

- | | | |
|---|--|---|
| <ol style="list-style-type: none"> 1. Extension housing 2. Oil seal (extension housing)
Assembly Note
..... page J-36 3. Shift guide assembly 4. Selector 5. Control rod end 6. Control rod
Assembly Note
..... page J-36 | <ol style="list-style-type: none"> 7. Select lock spindle 8. Select lock spindle spring 9. Spring cap 10. Select spindle assembly 11. Blind cover 12. Control case
Assembly Note
..... page J-36 | <ol style="list-style-type: none"> 13. Wave washer 14. Bushing 15. Bracket 16. 1-2 switch 17. Neutral switch 18. Oil guide 19. Power plant frame
installation bolts 20. Stopper |
|---|--|---|

J

TRANSMISSION

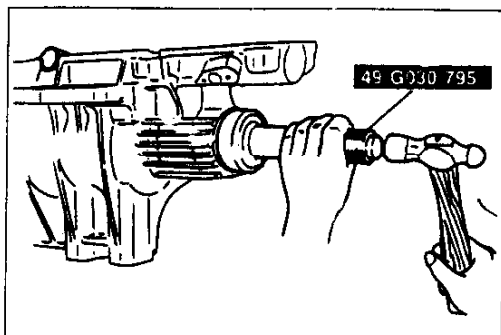

37U0JX-086

Assembly note

Oil seal (extension housing)

1. Apply clean oil to the lip and outer edge of a new oil seal.
2. Install the oil seal evenly and gradually by using the SST.

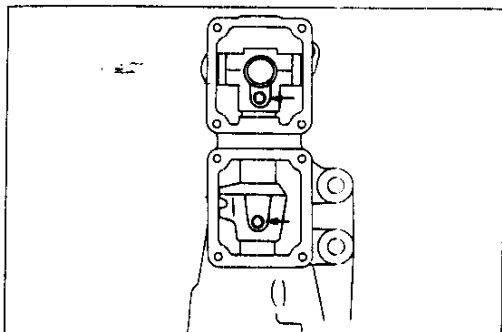

37U0JX-087

Control rod

1. Install the control rod through the selector and control rod end, into the extension housing.
2. Install new roll pins into the selector and control rod ends as shown in the figure.

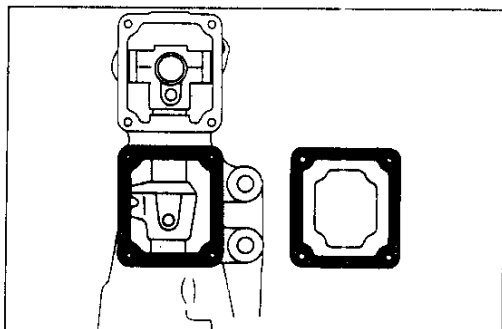

37U0JX-088

Blind cover

1. Apply sealant to the contact surfaces of the blind cover and extension housing.
2. Install the blind cover.

Tightening torque:

19–25 N·m {1.9–2.6 kgf·m, 14–18 ft·lbf}

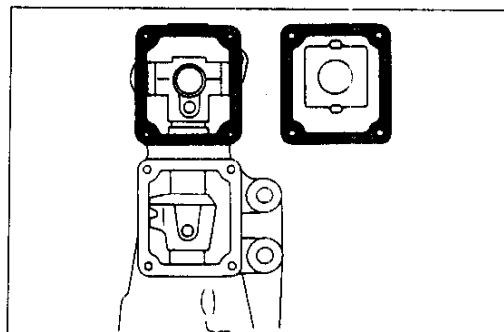

37U0JX-089

Control case

1. Apply sealant to the contact surfaces of the extension housing and control case.
2. Install the control case to the extension housing.

Tightening torque:

19–25 N·m {1.9–2.6 kgf·m, 14–18 ft·lbf}

MEMO

J

TRANSMISSION

Mainshaft and Countershaft Components

Assemble in the order shown, referring to **Assembly Note**.

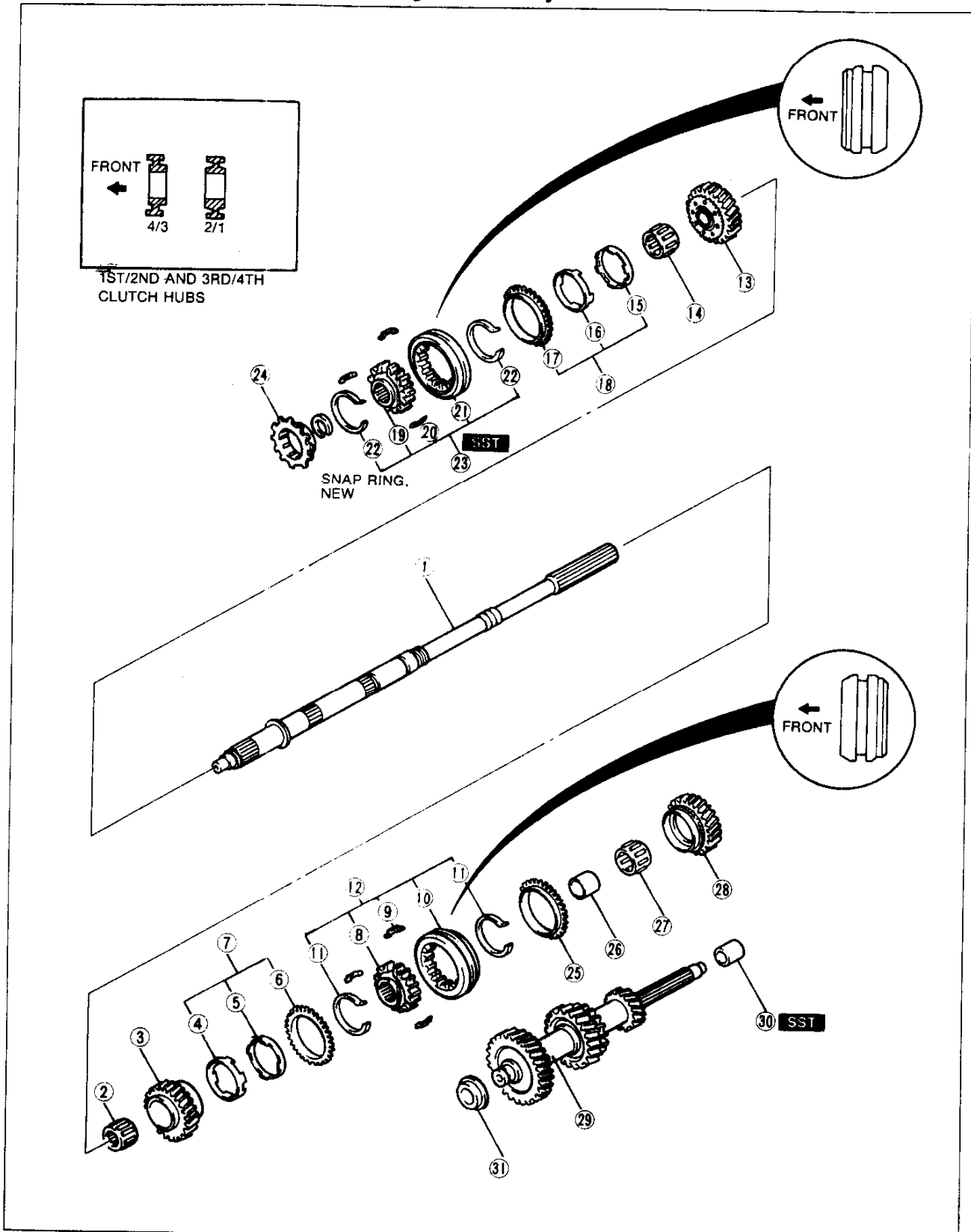

37U0JX-090

- | | | |
|---------------------------------|---------------------------------|---------------------------------------|
| 1. Mainshaft | 13. 3rd gear | 25. Synchronizer ring (1st) |
| 2. Bearing | 14. Bearing | 26. Bearing race |
| 3. 2nd gear | 15. Inner cone | 27. Bearing |
| 4. Inner cone | 16. Double cone | 28. 1st gear |
| 5. Double cone | 17. Synchronizer ring | 29. Countershaft |
| 6. Synchronizer ring | 18. Synchronizer assembly (3rd) | 30. Countershaft center bearing race |
| 7. Synchronizer assembly (2nd) | Assembly Note below | Assembly Note |
| Assembly Note below | 19. 3rd/4th clutch hub | page J-41 |
| 8. 1st/2nd clutch hub | 20. Synchronizer key | 31. Countershaft front bearing spacer |
| 9. Synchronizer key | 21. Clutch hub sleeve | Assembly Note |
| 10. Clutch hub sleeve | 22. Synchronizer key spring | page J-41 |
| 11. Synchronizer key spring | 23. 3rd/4th clutch hub assembly | |
| 12. 1st/2nd clutch hub assembly | Assembly Note below | |
| Assembly Note below | 24. Synchronizer ring (4th) | |

37U0JX-091

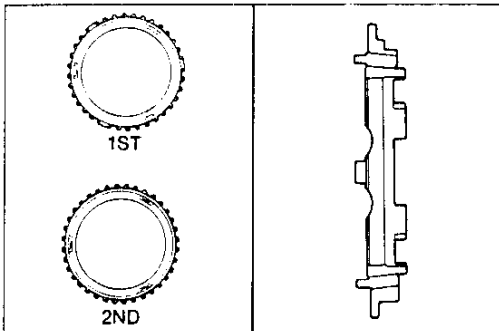

37J0JX-092

Assembly note

Synchronizer assembly (2nd, 3rd)

Note

- The 1st and 2nd synchronizer rings can be easily distinguished by noting that the 1st synchronizer ring has two teeth fused together at three equally spaced places around its outer edge. The 2nd synchronizer ring has no distinguishing marks.

Install the inner cone, double cone, and synchronizer ring as shown in the figure.

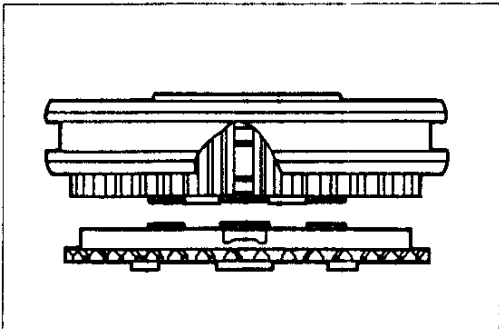

37J0JX-093

Clutch hub assembly (1st/2nd, 3rd/4th)

Caution

- Align the synchronizer ring grooves (2nd, 3rd) with the synchronizer keys during installation.
- Align the slots in the clutch hub with the tabs on the inner cone.

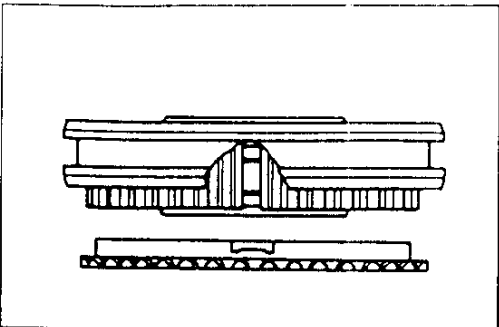

37U0JX-094

- Align the synchronizer ring grooves (1st, 4th) with the synchronizer keys.

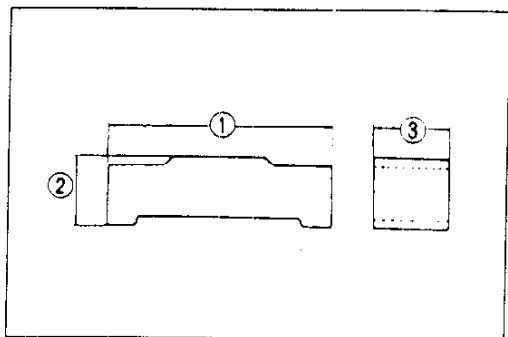

37U0JX-095

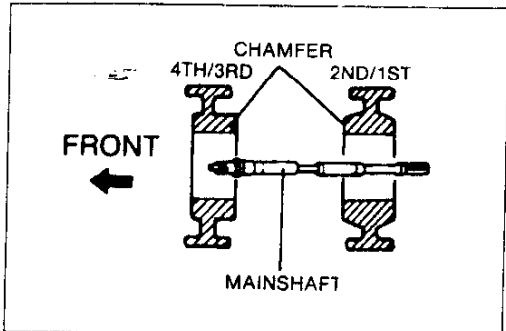

37U0JX-096

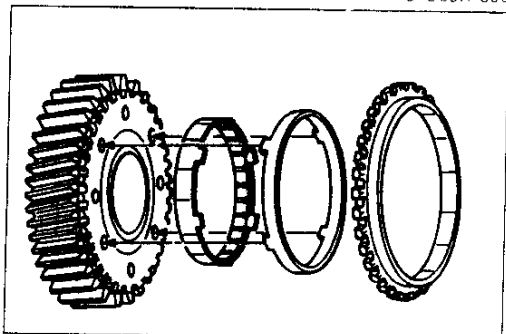

37J0JX-097

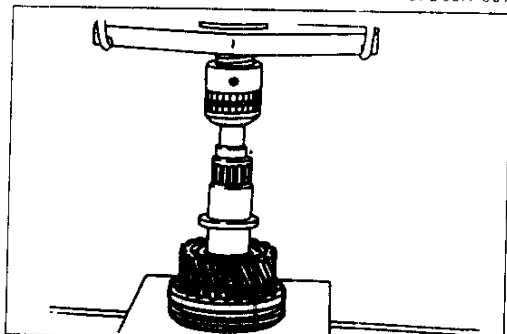

37U0JX-098

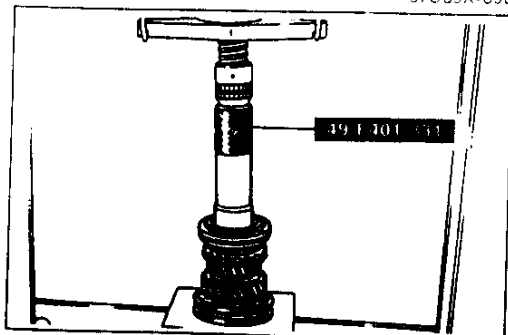

37U0JX-099

Note

- Standard key dimensions are as follows:

	mm {in}		
	1	2	3
1st and 2nd	18.00 {0.709}	5.45 {0.215}	6.00 {0.236}
3rd and 4th	17.00 {0.669}	4.25 {0.167}	5.00 {0.197}

Caution

- Press each clutch hub assembly onto the mainshaft in the proper direction as shown.

Caution

- Do not damage parts while using the press.
- Install the double cone pegs into the holes in the flank side of the gear as shown in the figure.

- 1 Set the needle bearing, 2nd gear, synchronizer assembly (2nd), and the 1st/2nd clutch hub assembly on the mainshaft, then press in the mainshaft.

- 2 Set the needle bearing, 3rd gear, synchronizer assembly (3rd), and 3rd/4th clutch hub assembly on the mainshaft, then press them onto the mainshaft by using the SST.

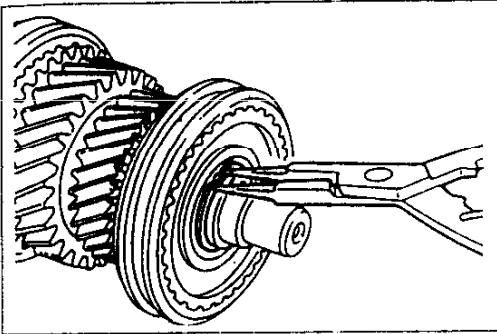

37U0JX-100

3. Install a new snap ring on the front of the mainshaft.

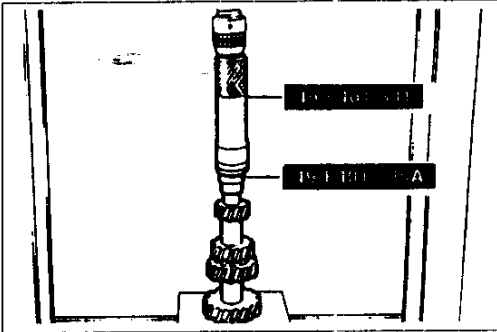

37U0JX-101

Countershaft center bearing race

Press the countershaft center bearing race onto the countershaft by using the **SST**.

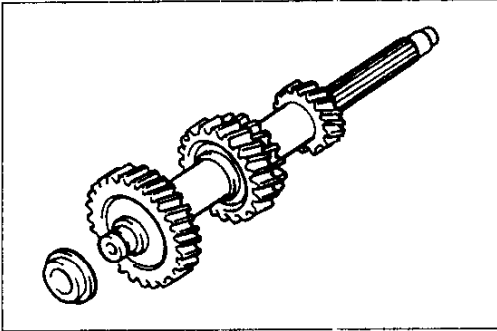

37U0JX-102

Countershaft front bearing spacer

Note

- **Replace the countershaft front bearing and countershaft front bearing spacer as one assembly.**

Install the countershaft front bearing spacer.

J

TRANSMISSION

Transmission Case Components

Assemble in the order shown, referring to **Assembly Note**.

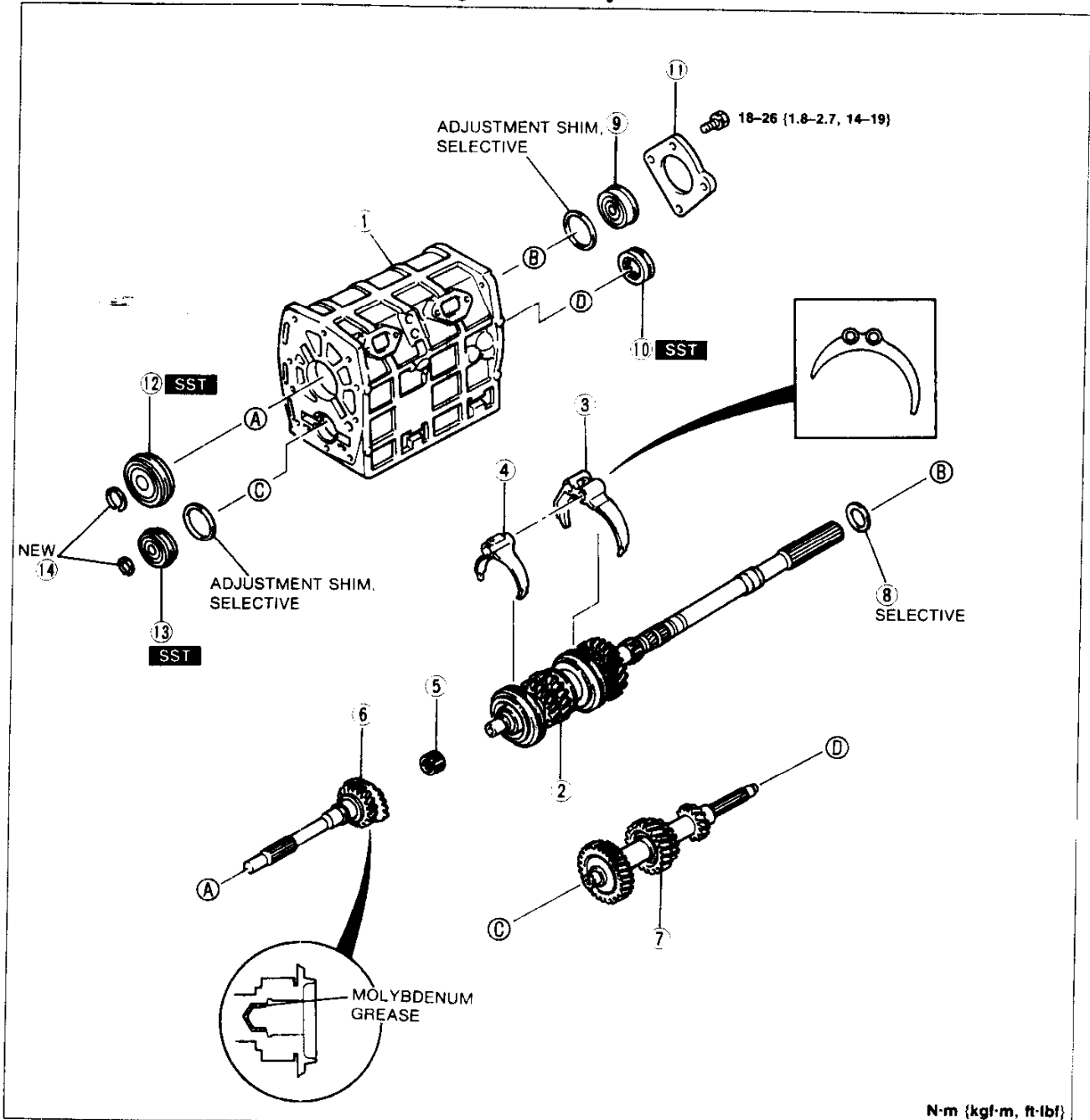

N·m (kgf·m, ft·lbf)

37U0JX-103

- | | | |
|--|--|--|
| 1. Transmission case
Assembly Note
..... page J-43 | 7. Countershaft assembly
8. Thrust washer
9. Mainshaft front bearing
Assembly Note
..... page J-44 | 12. Main drive gear bearing
Assembly Note
..... page J-44 |
| 2. Mainshaft gear assembly | 10. Countershaft center
bearing
Assembly Note
..... page J-44 | 13. Countershaft front bearing
Assembly Note
..... page J-45 |
| 3. 1st/2nd shift fork | 11. Bearing cover | 14. Snap rings |
| 4. 3rd/4th shift fork | | |
| 5. Bearing | | |
| 6. Main drive gear | | |

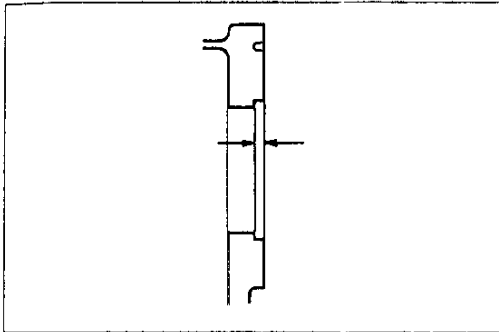

37U0JX-104

Assembly note
Transmission case

1. Measure the mainshaft front bearing thrust play as follows.

- (1) Measure the depth of the mainshaft front bearing bore in the rear of the transmission case.

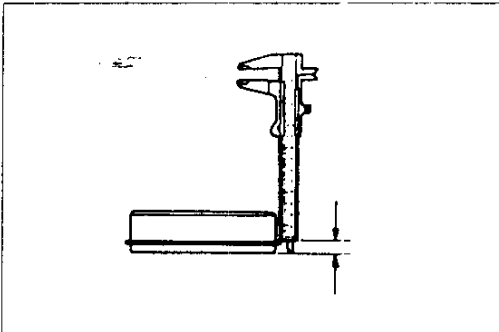

37U0JX-105

- (2) Measure the mainshaft front bearing height. The difference between the two measurements indicates the required thickness of the adjustment shim.

Standard thrust play:

0–0.05 mm {0–0.002 in}

Adjustment shim thicknesses:

0.1 mm {0.004 in}, 0.3 mm {0.012 in}

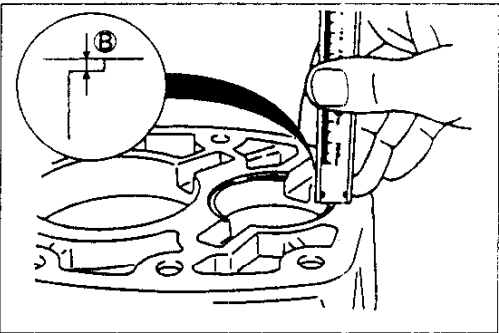

37U0JX-106

2. Measure the countershaft front bearing thrust play as follows.

- (1) Measure depth B of the countershaft front bearing bore in the transmission case.

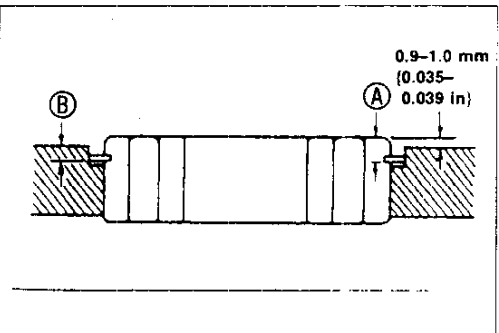

37J0JX-107

- (2) Measure the countershaft front bearing snap ring height A.

- (3) Choose an adjustment shim that will allow the difference between the two measurements to be equal to the standard bearing height.

A-B + Adjustment shim(s) = 0.9–1.0 mm {0.035–0.039 in}

Standard bearing height on installing:

0.9–1.0 mm {0.035–0.039 in}

Adjustment shim thicknesses:

0.1 mm {0.004 in}, 0.3 mm {0.012 in}

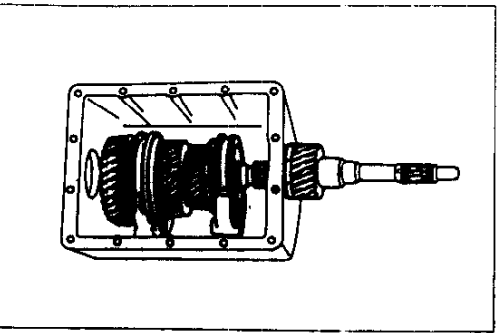

37U0JX-108

3. Position the 1st/2nd and 3rd/4th shift forks into the grooves of the clutch hub and sleeve assemblies.

4. Apply molybdenum grease to the needle bearing and install it in the main drive gear.

5. Install the main drive gear onto the front of the mainshaft.

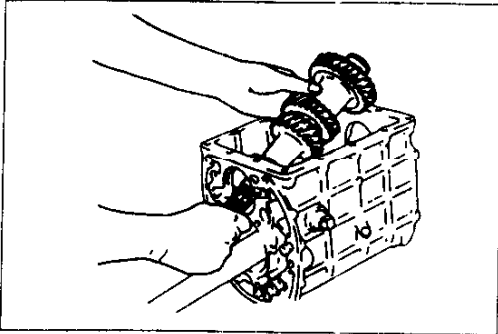

37U0JX-109

- Set the countershaft assembly into the case, making sure the countershaft gears engage each gear of the mainshaft assembly.

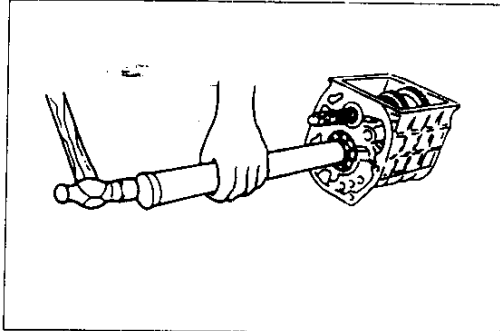

37U0JX-110

Mainshaft front bearing

- Install the correct shim onto the rear of the mainshaft as determined in the transmission case assembly note (page J-43.)
- Install the mainshaft front bearing with a suitable pipe.

Bearing inner diameter: 32 mm {1.3 in}
Bearing outer diameter: 75 mm {3.0 in}

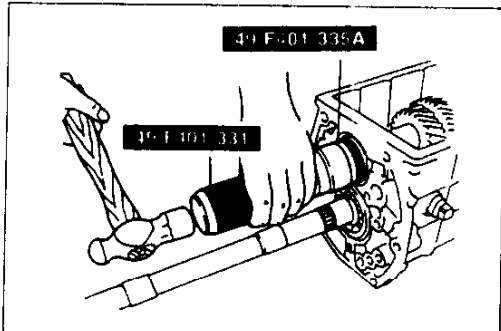

37U0JX-111

Countershaft center bearing

- Install the countershaft center bearing onto the rear of the countershaft by using the **SST**.

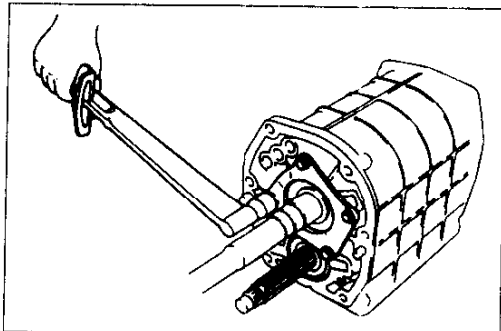

37U0JX-112

- Install the bearing cover.

Tightening torque:
18-26 N·m {1.8-2.7 kgf·m, 14-19 ft·lbf}

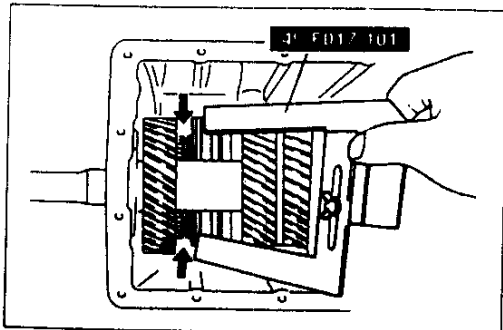

37U0JX-113

Main drive gear bearing

- Install the **SST** between the 4th synchronizer ring and the main drive synchromesh gear.

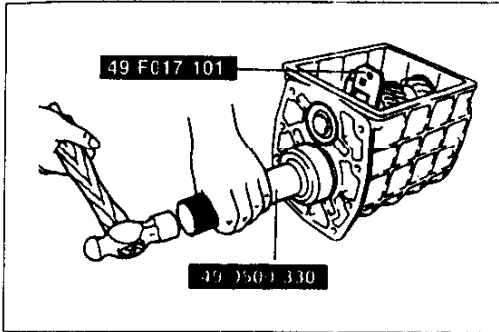

37U0JX-114

2. Install the main drive gear bearing by using the **SST**.

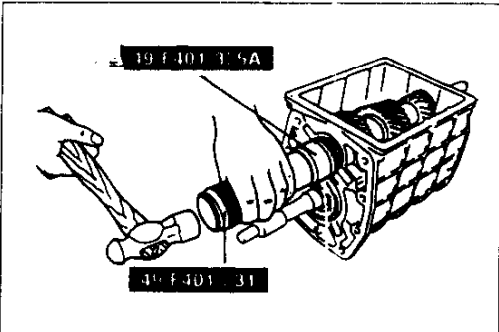

37U0JX-115

Countershaft front bearing

Note

- Replace the countershaft front bearing and countershaft front bearing spacer as an assembly.

1. Install the correct shim onto the countershaft front bearing as determined in the transmission case assembly note (page J-43.)
2. Install the countershaft front bearing by using the **SST**.

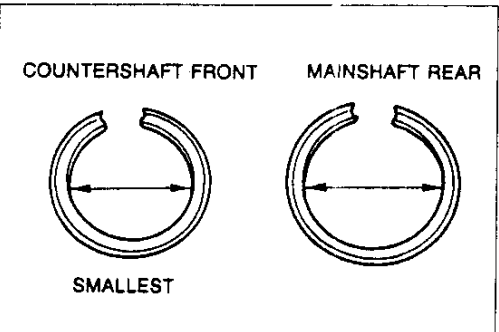

37U0JX-116

Note

- Do not confuse the front and rear bearing snap rings. The countershaft front snap ring is the smallest.

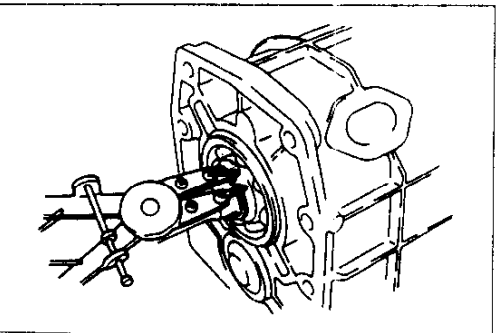

37U0JX-117

3. Install new snap rings to the main drive gear and countershaft gear.

5th/Reverse Gear and Housing Components

Assemble in the order shown, referring to **Assembly Note**.

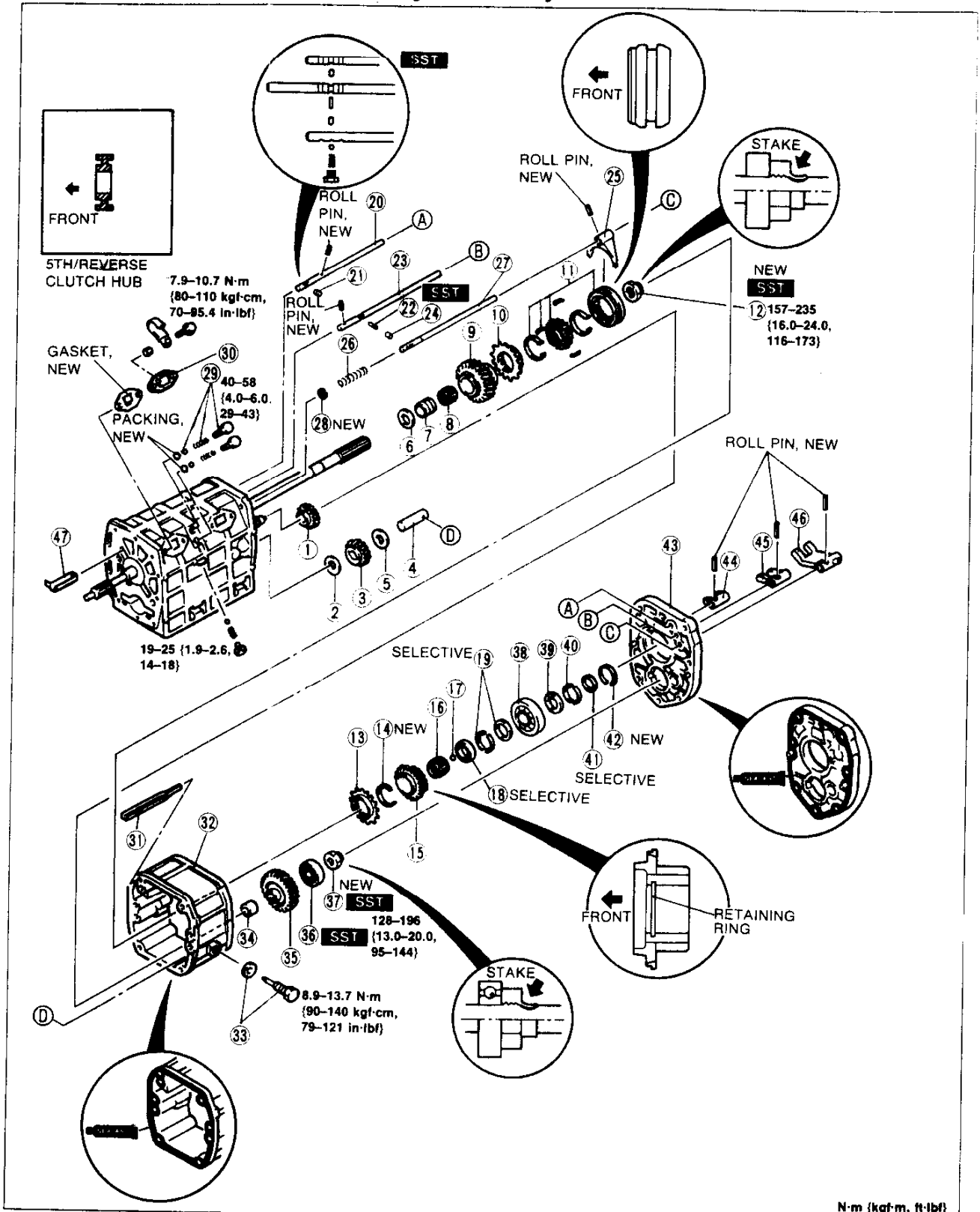

N-m (kgf-m, ft-lbf)
 37U0JX-118

- | | | |
|--|---|---|
| <ol style="list-style-type: none"> 1. Counter reverse gear 2. Thrust washer 3. Reverse idler gear 4. Reverse idler gear shaft 5. Thrust washer 6. Thrust washer 7. Bearing race 8. Bearing 9. Reverse gear 10. Synchronizer ring (Reverse)
Assembly Note below 11. 5th/Reverse clutch hub assembly
Assembly Note below 12. Locknut
Assembly Note below 13. Synchronizer ring (5th)
Assembly Note below 14. Retaining ring 15. 5th gear
Assembly Note page J-48 16. Bearing 17. Steel ball | <ol style="list-style-type: none"> 18. Thrust lock washer 19. C-washers and retaining ring 20. 1st/2nd shift rod
Assembly Note page J-49 21. Interlock pin (large) 22. Interlock pin (small) 23. 3rd/4th shift rod
Assembly Note page J-49 24. Interlock pin (large) 25. 5th/Reverse shift fork
Assembly Note page J-49 26. Spring 27. 5th/Reverse shift rod
Assembly Note page J-49 28. Retaining ring 29. Cap plug, spring, and detent ball 30. Blind cover 31. Oil guide 32. Center housing
Assembly Note page J-50 | <ol style="list-style-type: none"> 33. Set bolt and washer 34. Spacer 35. Counter 5th gear 36. Countershaft rear bearing
Assembly Note page J-51 37. Locknut 38. Mainshaft rear bearing
Assembly Note page J-51 39. Retaining ring 40. C-washers 41. Thrust washer 42. Snap ring 43. Bearing housing
Assembly Note page J-52 44. 1st/2nd shift rod end
Assembly Note page J-52 45. 3rd/4th shift rod end
Assembly Note page J-52 46. 5th/Reverse shift rod end
Assembly Note page J-52 47. Oil guide |
|--|---|---|

37U0JX-119

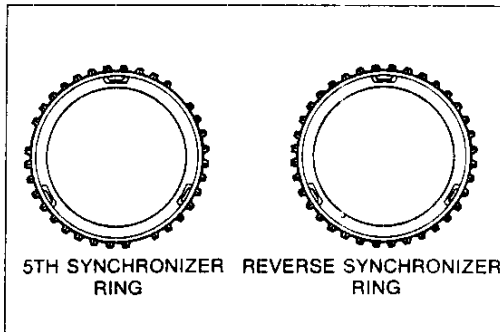

37U0JX-120

Assembly note Synchronizer ring (5th/Reverse)

The 5th and Reverse synchronizer rings are differentiated as follows.

- (1) The 5th synchronizer ring has 3 places on its circumference with one tooth missing in each place.
- (2) The Reverse synchronizer ring has no distinguishing marks.

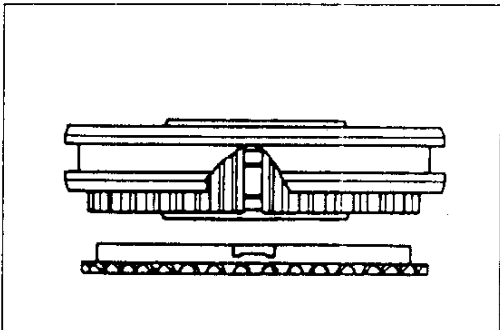

37U0JX-121

5th/Reverse clutch hub assembly and locknut

Caution

- Align the 5th/Reverse synchronizer grooves with the synchronizer keys.

Note

- Standard key dimensions are as follows.

mm {in}

	1	2	3
5th/Reverse	17.00 {0.669}	4.250 {0.167}	5.00 {0.197}

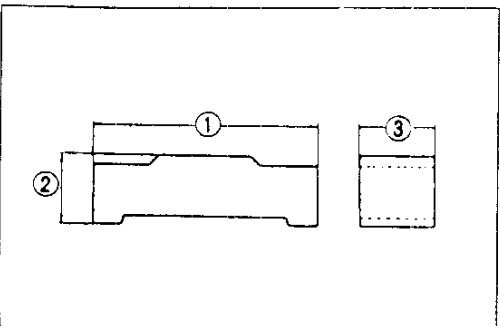

37U0JX-122

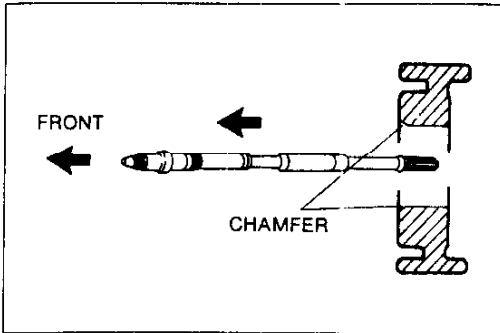

37U0JX-123

Caution

- Install the 5th/Reverse clutch hub assembly in the proper direction as shown.

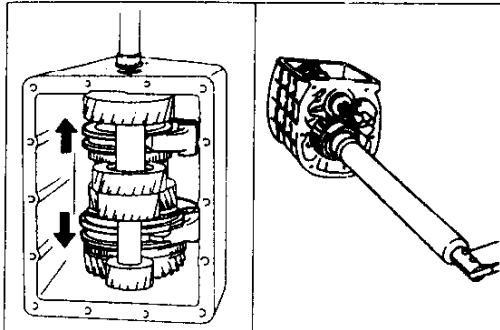

37U0JX-124

1. Shift the clutch hubs into 1st and 4th gears to lock the rotation of the mainshaft.
2. Install a new locknut and tighten it with the SST.

Tightening torque:

157–235 N·m {16.0–24.0 kgf·m, 116–173 ft·lbf}

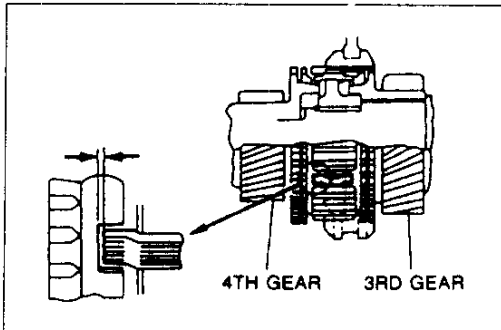

37U0JX-125

Caution

- The total combined thickness of the front and rear thrust washers must equal 6.0 mm {0.236 in}.

3. Check the clearance between the synchronizer key and the exposed edge of the synchronizer ring. If it is not as specified, adjust by changing the thrust washers on the front and rear of the mainshaft front bearing.

Clearance: 0.66–2.0 mm {0.026–0.079 in}

Available thrust washer thicknesses:

2.5 mm {0.098 in}, 3.0 mm {0.118 in},
3.5 mm {0.138 in}

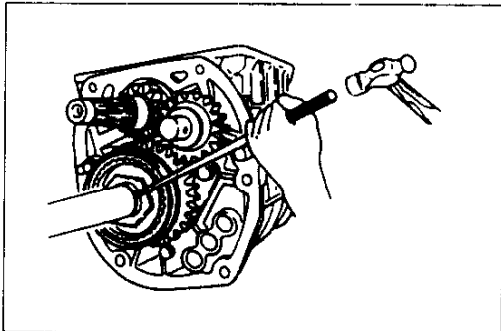

37U0JX-126

4. Stake the locknut into the mainshaft groove.

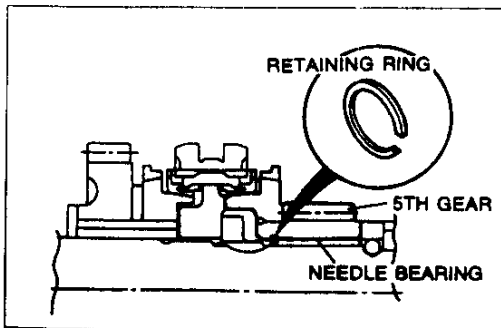

37U0JX-127

5th gear

1. Install a new retaining ring to the 5th gear.

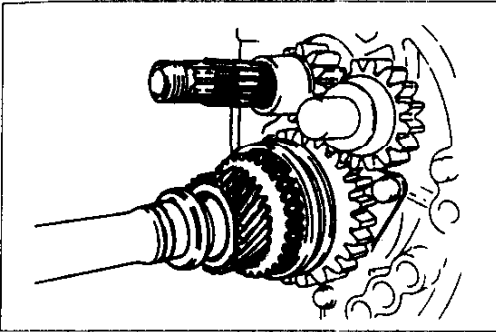

37U0JX-128

2. Install the synchronizer ring, 5th gear, and needle bearing.
3. Install the steel ball and thrust lock washer.
4. Install the 3.0 mm {0.118 in} C-washers and hold them with a retaining ring.

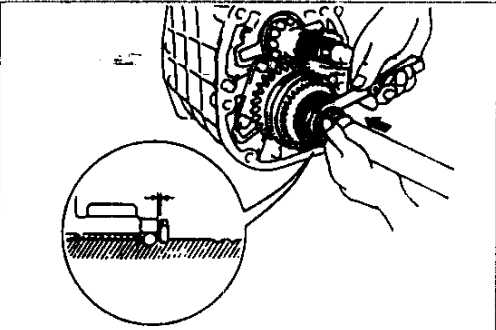

37J0JX-129

5. Push the C-washers toward 5th gear and measure the clearance between the C-washers and thrust lock washer. If the clearance is not as specified, select the proper thrust lock washer.

Standard: 0.1–0.2 mm {0.004–0.008 in}

Available thrust lock washer thicknesses:

- 6.2 mm {0.244 in}, 6.3 mm {0.248 in}
- 6.4 mm {0.252 in}, 6.5 mm {0.256 in}
- 6.6 mm {0.260 in}, 6.7 mm {0.264 in}

Shift forks and rods

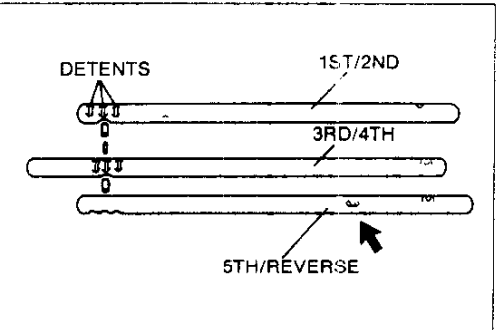

37U0JX-130

Note

- A simple way to identify the shift rods is as follows:
- The 3rd/4th shift rod is the longest.
- The 5th/Reverse shift rod has an extra hole for the shift fork roll pin at the rear of the rod.
- When installing the shift rods, set the detents toward the ball side.

Caution

- The roll pin must be installed with the split as shown.

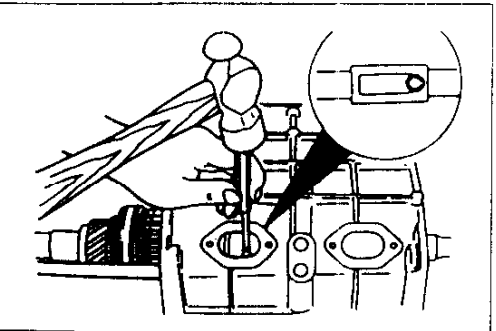

37U0JX-131

1. Slide the 1st/2nd shift rod into the case.
2. Secure the 1st/2nd shift fork to the rod with a new roll pin.

Note

- The interlock pins must be installed as shown.

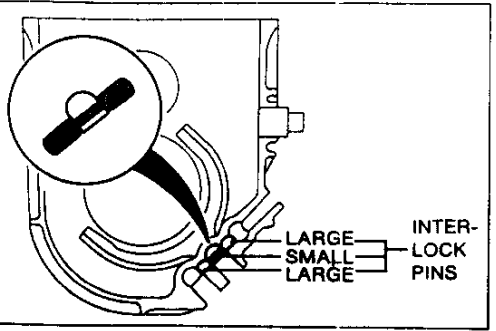

37U0JX-132

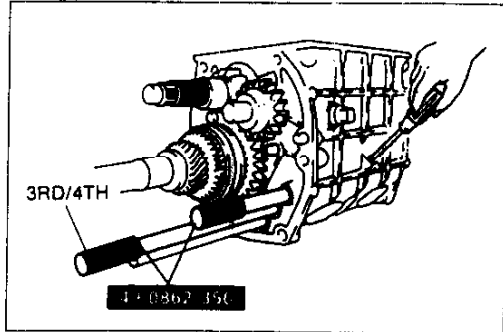

3. Slide the two **SST** into the transmission case to guide the interlock pins, and insert the first pin.
4. Remove the 3rd/4th shift fork guide from the case.
5. Slide the 3rd/4th shift rod containing the interlock pin (small) into the case.
6. Secure the 3rd/4th shift rod onto the fork with the new roll pin.
7. Insert the remaining interlock pin and remove the **SST**

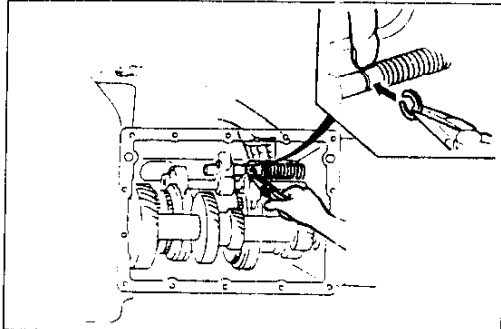

8. Install the 5th/Reverse shift fork onto the clutch hub.
9. Install the 5th/Reverse shift rod in the transmission case through the spring.
10. Push back the spring, and install a new clip to the 5th/Reverse shift rod.

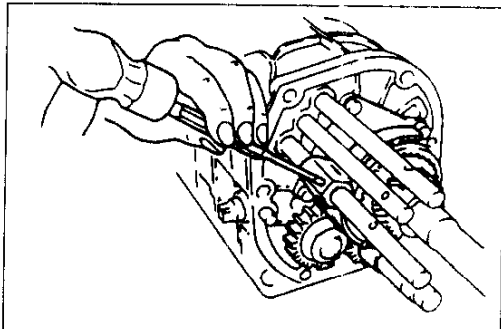

11. Install a new roll pin into the 5th/Reverse shift fork.

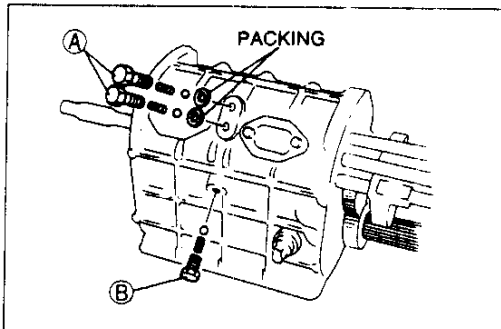

12. Install the two blind covers and two new gaskets.

Tightening torque:

7.9–10.7 N·m {80–110 kgf·cm, 70–95.4 in·lbf}

13. Install the packings, detent balls, springs, and cap bolts.

Tightening torque:

A: 40–58 N·m {4.0–6.0 kgf·m, 29–43 ft·lbf}

B: 19–25 N·m {1.9–2.6 kgf·m, 14–18 ft·lbf}

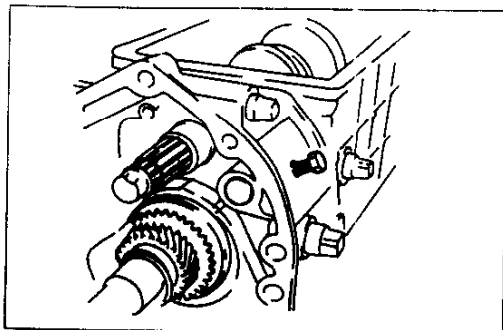

Center housing

1. Apply sealant to the contact surfaces of the transmission case and center housing.
2. Install the oil guide.
3. Install the center housing.
4. Align the reverse idler gear shaft with the set bolt hole, and install the set bolt and washer.

Tightening torque:

8.9–13.7 N·m {90–140 kgf·cm, 79–121 in·lbf}

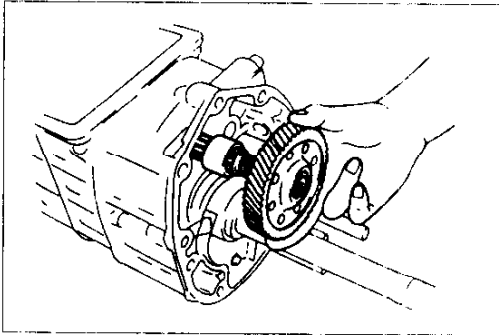

37U0JX 138

5. Install the spacer and counter 5th gear.

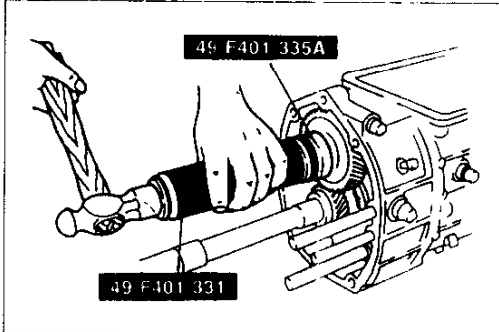

37U0JX 139

Countershaft rear bearing

1. Install the countershaft rear bearing by using the **SST**

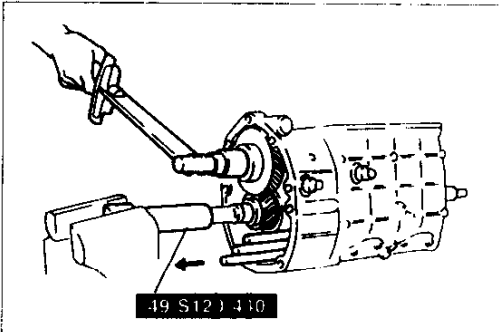

37J0JX 140

2. Connect the **SST** to the mainshaft and mount it securely in a vise.
3. Shift into 1st gear to lock the countershaft.
4. Install the new countershaft locknut.

Tightening torque:

128–196 N·m {13.0–20.0 kgf·m, 95–144 ft·lbf}

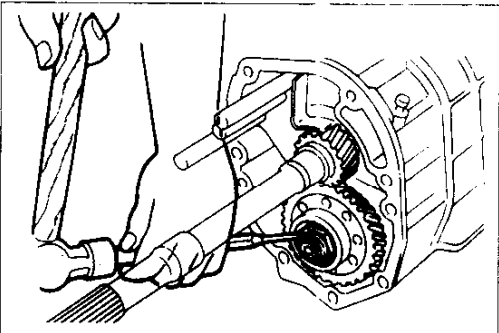

37J0JX 141

5. Stake the locknut into the countershaft groove.

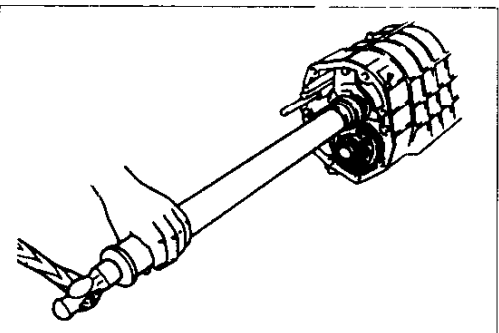

37J0JX 142

Mainshaft rear bearing

1. Drive on the mainshaft rear bearing with a suitable pipe

Bearing diameter (inner): 22 mm {0.87 in}

Bearing diameter (outer): 56 mm {2.2 in}

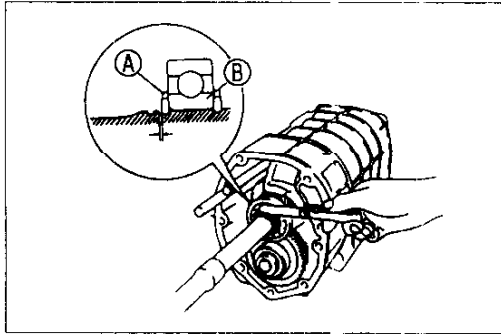

37 J0JX-143

2. Install the C-washers and hold them in place with a new retaining ring.
3. With points A and B pressed tightly together, measure the clearance between the C-washers and the groove. If the clearance is not as specified, select the proper C-washers.

Standard: 0–0.1 mm {0–0.004 in}

Available C-washer thicknesses:

2.9 mm {0.114 in}, 3.0 mm {0.118 in}

3.1 mm {0.122 in}, 3.2 mm {0.126 in}

Bearing housing

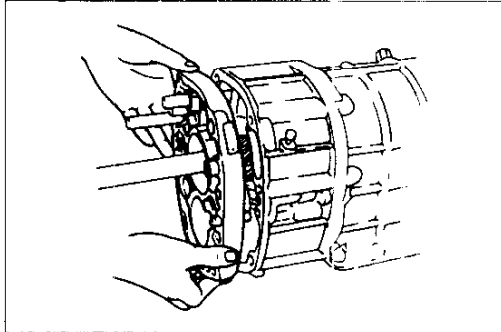

37 J0JX-144

1. Apply sealant to the contact surfaces of the center housing and bearing housing.
2. Install the bearing housing onto the center housing.

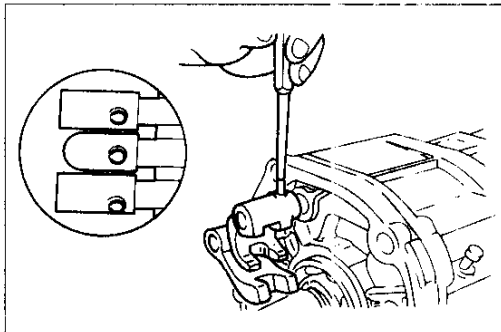

37 J0JX-145

Shift rod ends

Install the shift rod ends onto the proper shift rods, and secure them with new roll pins facing as shown in the figure.

TRANSMISSION

J

Clutch Housing and Extension Housing Components

Assemble in the order shown, referring to **Assembly Note**.

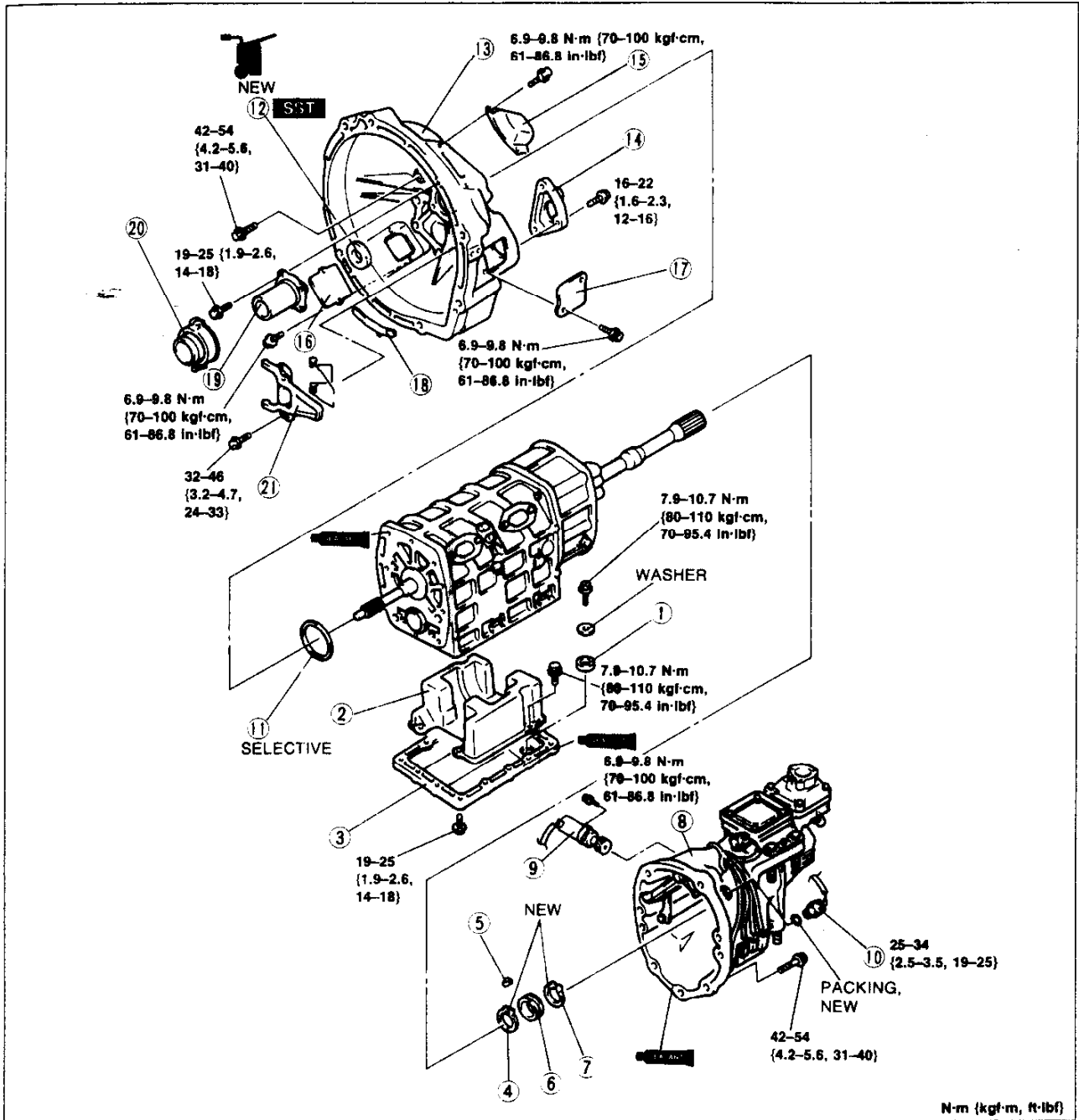

N·m {kgf·m, ft·lbf}

37U0JX-146

- | | | |
|--|---|---|
| 1. Magnet | 9. Speedometer sensor
(Speedometer driven gear) | 15. Vent cover |
| 2. Oil baffle | 10. Back-up light switch | 16. Service hole B cover |
| 3. Undercover
Assembly Note
..... page J-54 | 11. Assist shim | 17. Service hole A cover |
| 4. Snap ring | 12. Oil seal (clutch housing)
Assembly Note
..... page J-54 | 18. Dust cover |
| 5. Key | 13. Clutch housing
Assembly Note
..... page J-54 | 19. Front cover |
| 6. Speedometer drive gear | 14. Release cylinder support | 20. Release collar
Assembly Note
..... page J-55 |
| 7. Snap ring | | 21. Release fork assembly
Assembly Note
..... page J-55 |
| 8. Extension housing
Assembly Note
..... page J-54 | | |

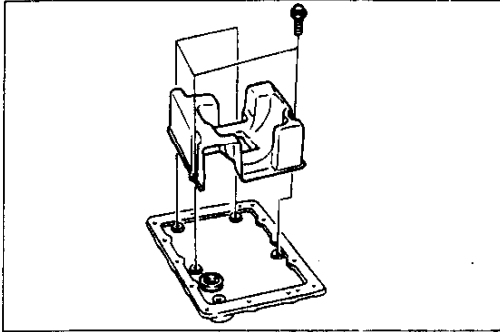

37U0JX-147

Assembly note

Undercover

1. Install the magnet to the undercover.

Tightening torque:

7.9–10.7 N·m {80–110 kgf·cm, 70–95.4 in·lbf}

2. Install the oil baffle to the undercover.

Tightening torque:

7.9–10.7 N·m {80–110 kgf·cm, 70–95.4 in·lbf}

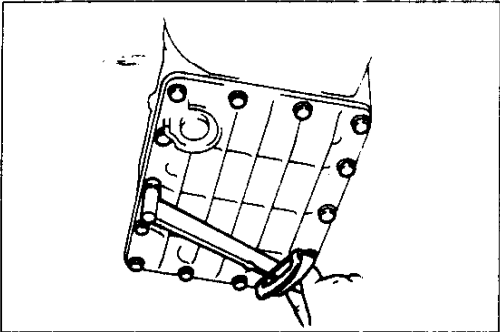

37UCJX-148

3. Apply sealant to the contact surfaces of the undercover and the transmission case.

4. Install the undercover.

Tightening torque:

19–25 N·m {1.9–2.6 kgf·m, 14–18 ft·lbf}

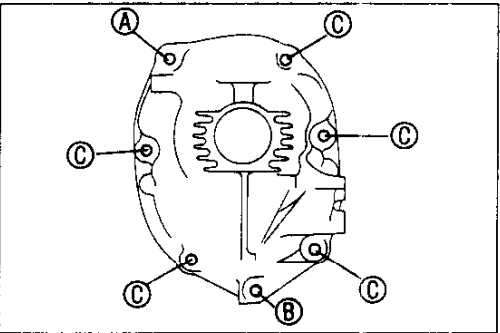

37U0JX-149

Extension housing

1. Apply sealant to the contact surfaces of the extension housing and bearing housing.
2. Install the extension housing.

Bolt length (measured from below the head):

A: 135 mm {5.31 in}

B: 48 mm {1.89 in}

C: 165 mm {6.50 in}

Tightening torque:

42–54 N·m {4.2–5.6 kgf·m, 31–40 ft·lbf}

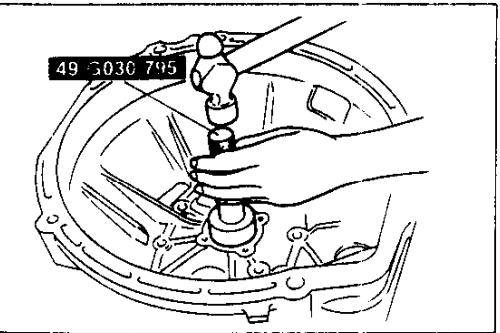

37U0JX-150

Oil seal (clutch housing)

1. Apply the specified oil to the lip of a new oil seal.
2. Install the oil seal evenly by using the **SST**.

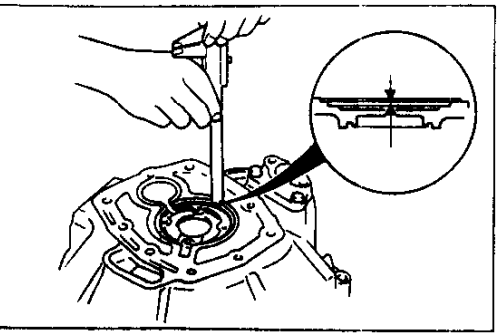

37U0JX-151

Clutch housing

1. Measure the depth of the main drive gear bearing bore in the clutch housing by using vernier calipers.

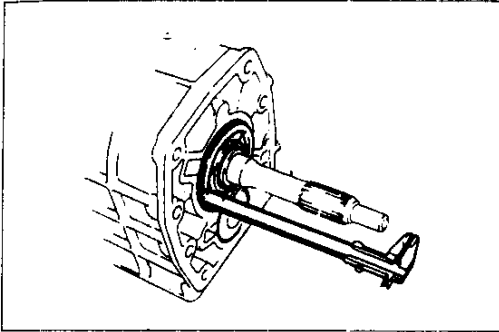

37UCJX-152

Caution

● **Make the following measurement after assembling the transmission case.**

2. Measure the main drive gear bearing height.
3. The difference between the measurements in steps 1 and 2 indicates the required thickness of the adjustment shim.

Standard thrust play: 0–0.1 mm {0–0.004 in}

Adjustment shim thicknesses:

- 0.3 mm {0.012 in}, 0.4 mm {0.016 in}
- 0.5 mm {0.020 in}, 0.6 mm {0.024 in}
- 0.7 mm {0.028 in}

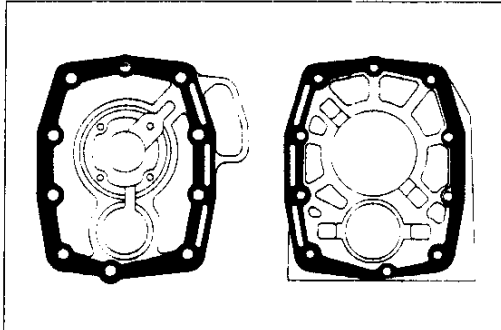

37U0JX-153

4. Apply sealant to the contact surfaces of the clutch housing and transmission case.
5. Install the correct adjustment shim on the main drive gear bearing as determined in steps 1 and 2.

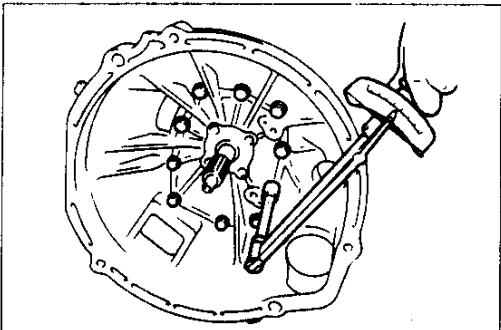

37U0JX-154

6. Install the clutch housing.

Tightening torque:

42–54 N·m {4.2–5.6 kgf·m, 31–40 ft·lbf}

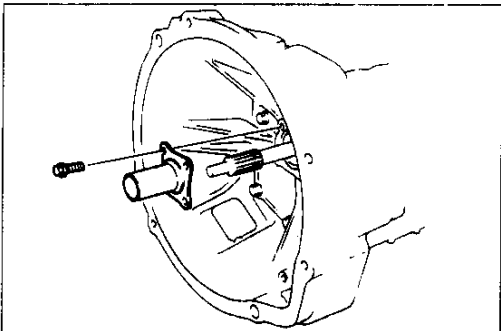

37U0JX-155

7. Install the front cover to the clutch housing.

Tightening torque:

19–25 N·m {1.9–2.6 kgf·m, 14–18 ft·lbf}

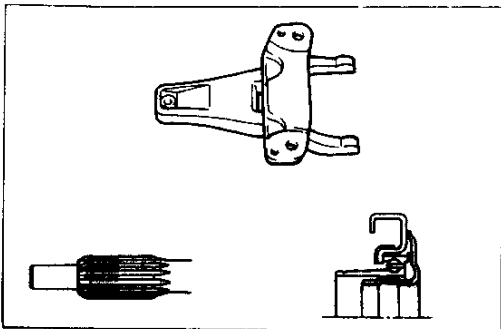

37U0JX-156

Release collar and release fork assembly

1. Apply molybdenum grease to the shaded areas of the release bearing and release fork.

J

TRANSMISSION

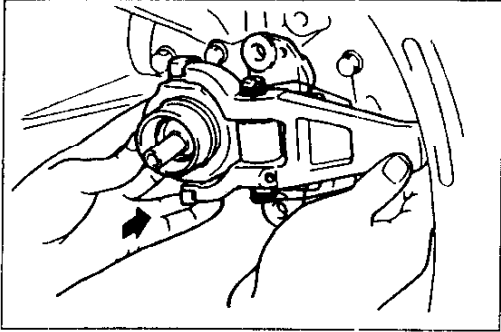

37U0JX-157

2. Install the release bearing and release fork assembly.

Tightening torque:

32–46 N·m {3.2–4.7 kgf·m, 24–33 ft·lbf}

TRANSMISSION

J

INSTALLATION

1. Install in the order shown, referring to **Installation Note**.
2. After installation, fill the transmission with the specified oil and do a road test.

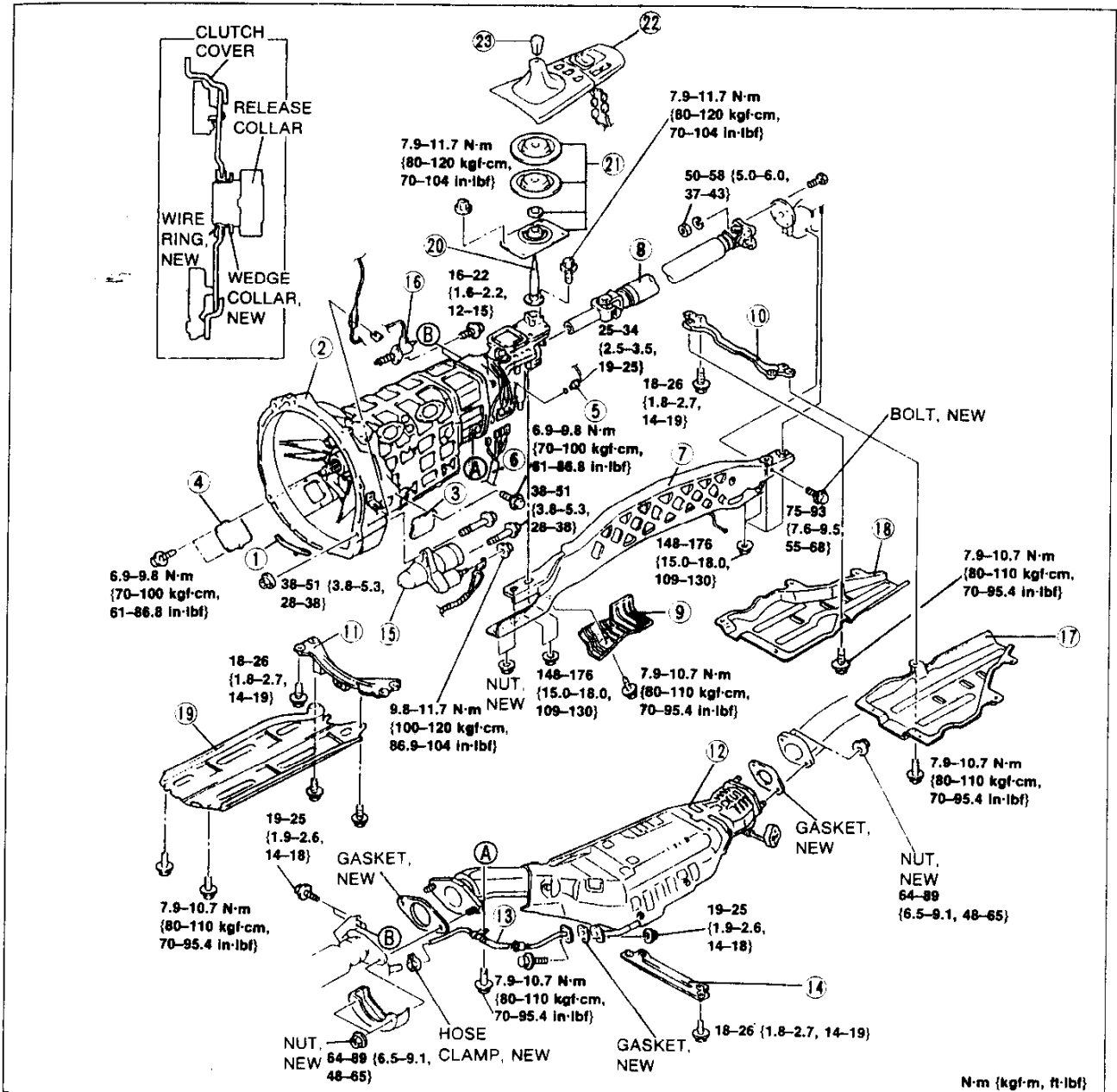

N-m {kgf-m, ft-lbf}

37U0JX-158

- | | | |
|----------------------------|-----------------------------|-----------------------------|
| 1. Dust cover | 8. Propeller shaft | 14. Tunnel reinforcement |
| 2. Transmission | Installation Note | (center) |
| Installation Note | page J-60 | 15. Starter |
| page J-58 | | 16. Clutch release cylinder |
| 3. Service hole A cover | 9. Cover | 17. Left undercover |
| 4. Service hole B cover | 10. Tunnel reinforcement | 18. Right undercover |
| 5. Back-up light switch | (rear) | 19. Transmission cover |
| 6. Connectors | 11. Tunnel reinforcement | 20. Shift lever assembly |
| 7. Power Plant Frame (PPF) | (front) | 21. Insulator assembly |
| Installation Note | 12. Catalytic converter | 22. Console panel assembly |
| page J-59 | assembly | 23. Shift lever knob |
| | 13. Secondary air injection | |
| | pipe | |

J

TRANSMISSION

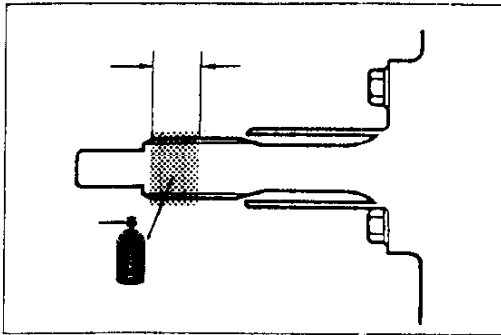

37U0JX-159

Installation Note Transmission

Caution

- Do not install the back-up light switch until after the transmission is installed.

1. Coat the main drive gear splines with grease as shown in the figure.

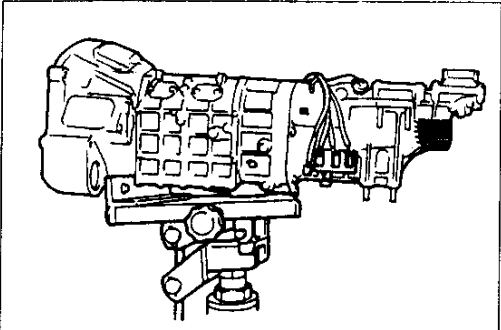

37U0JX-160

Warning

- Do not allow the transmission to fall from the jack.

2. Set the transmission on a transmission jack.

Caution

- Do not damage the wedge collar when installing the transmission to the engine.
- Do not damage the harnesses, clutch pipe, or clutch release cylinder.

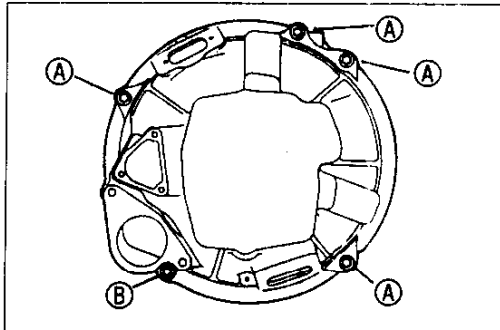

37U0JX-161

3. Raise the transmission into place and install it to the engine.

4. Tighten the installation bolts.

Bolt length:

A: 55 mm {2.2 in}

B: 90 mm {3.5 in}

Tightening torque:

38–51 N·m {3.8–5.3 kgf·m, 28–38 ft·lbf}

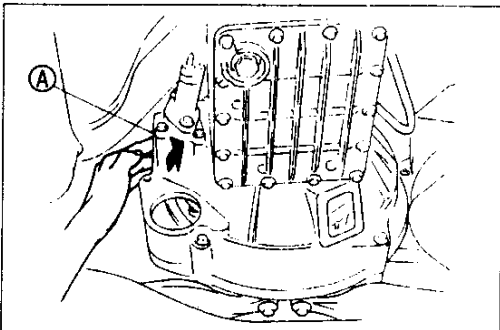

37U0JX-162

Caution

- Make sure that the clutch release collar snaps properly into the clutch cover.

5. Through service hole A, push the release-cylinder end of the clutch release fork toward the transmission, and connect the clutch release collar to the clutch cover.

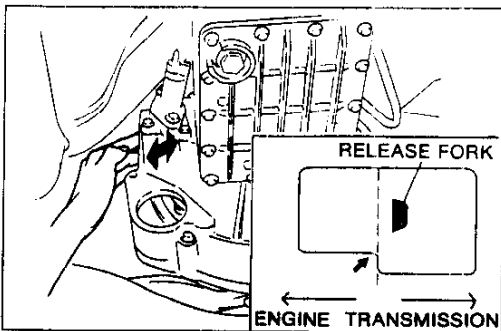

37U0JX-174

6. Swing the clutch release fork back and forth to verify that the clutch release collar is connected to the clutch cover.

7. Push the release-cylinder end of the clutch release fork toward the engine, and verify that it does not move past the dotted line.

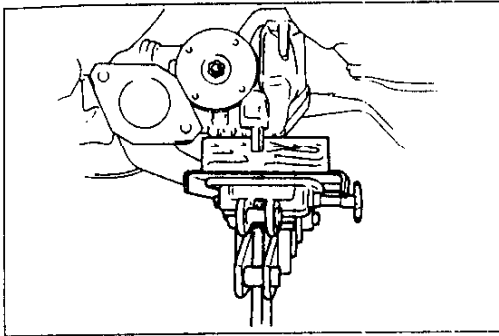

37U0JX-163

Power plant frame (PPF)

Caution

- Do not reuse PPF installation nuts.

1. Hold the differential at a 0° angle by using the transmission jack.

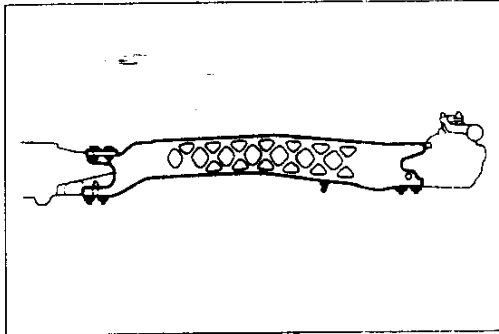

37U0JX-164

2. Hold the PPF in place with a new bolt and 8 new nuts.

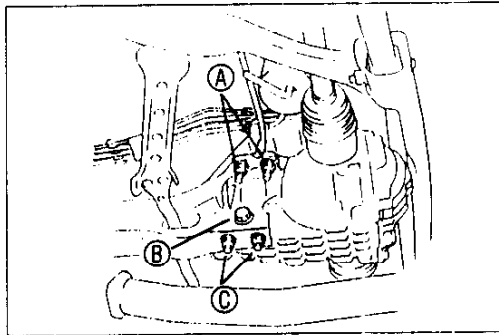

37U0JX-165

Caution

- Tighten the differential-side PPF installation bolt/nuts first.

3. Tighten the differential-side PPF installation bolt and nuts in the order shown.

Tightening torque:

- A, C: 148–176 N·m {15.0–18.0 kgf·m, 109–130 ft·lbf}
- B: 75–93 N·m {7.6–9.5 kgf·m, 55–68 ft·lbf}

4. Tighten the transmission-side PPF installation nuts in the order shown.

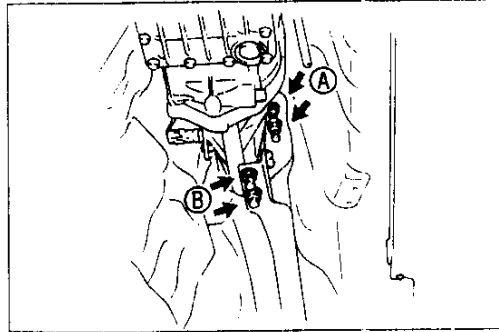

37U0JX-166

Tightening torque:

- 148–176 N·m {15.0–18.0 kgf·m, 109–130 ft·lbf}

5. Remove the transmission jack.

6. Lower the vehicle to the ground, and remove the SST (engine supports).

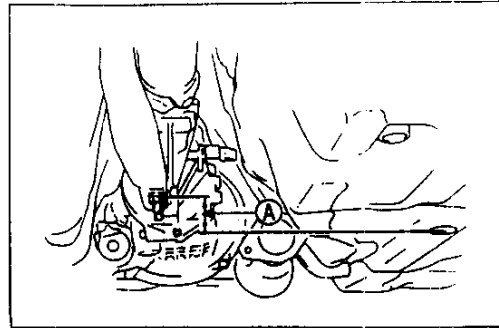

37U0JX-167

7. Measure A as shown in the figure.

Standard:

- Right: 73 mm {2.9 in} min.
- Left : 75 mm {3.0 in} min.

Note

- When measuring by using a straight edge placed on both the right and left sides, the clearance should be 74.0 mm {2.91 in} minimum.

8. If outside the standard, readjust the PPF.

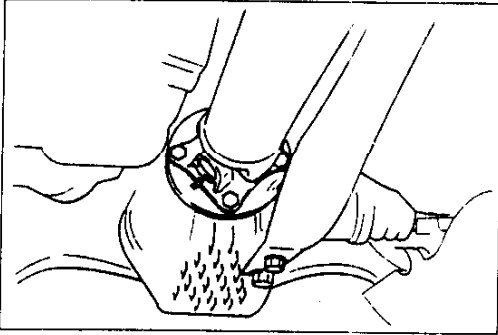

37U0.JX.168

Propeller shaft

1. Align the marks on the flanges (made during removal).
2. Install the propeller shaft.

Tightening torque:**50–58 N·m {5.0–6.0 kgf·m, 37–43 ft·lbf}**

SHIFT MECHANISM

OVERHAUL

1. Disassemble as shown in the figure.
2. Inspect each part, and replace if necessary.
3. Assemble in the reverse order of disassembly.
4. After assembly, pump the clutch pedal and verify that the shift lever moves smoothly.

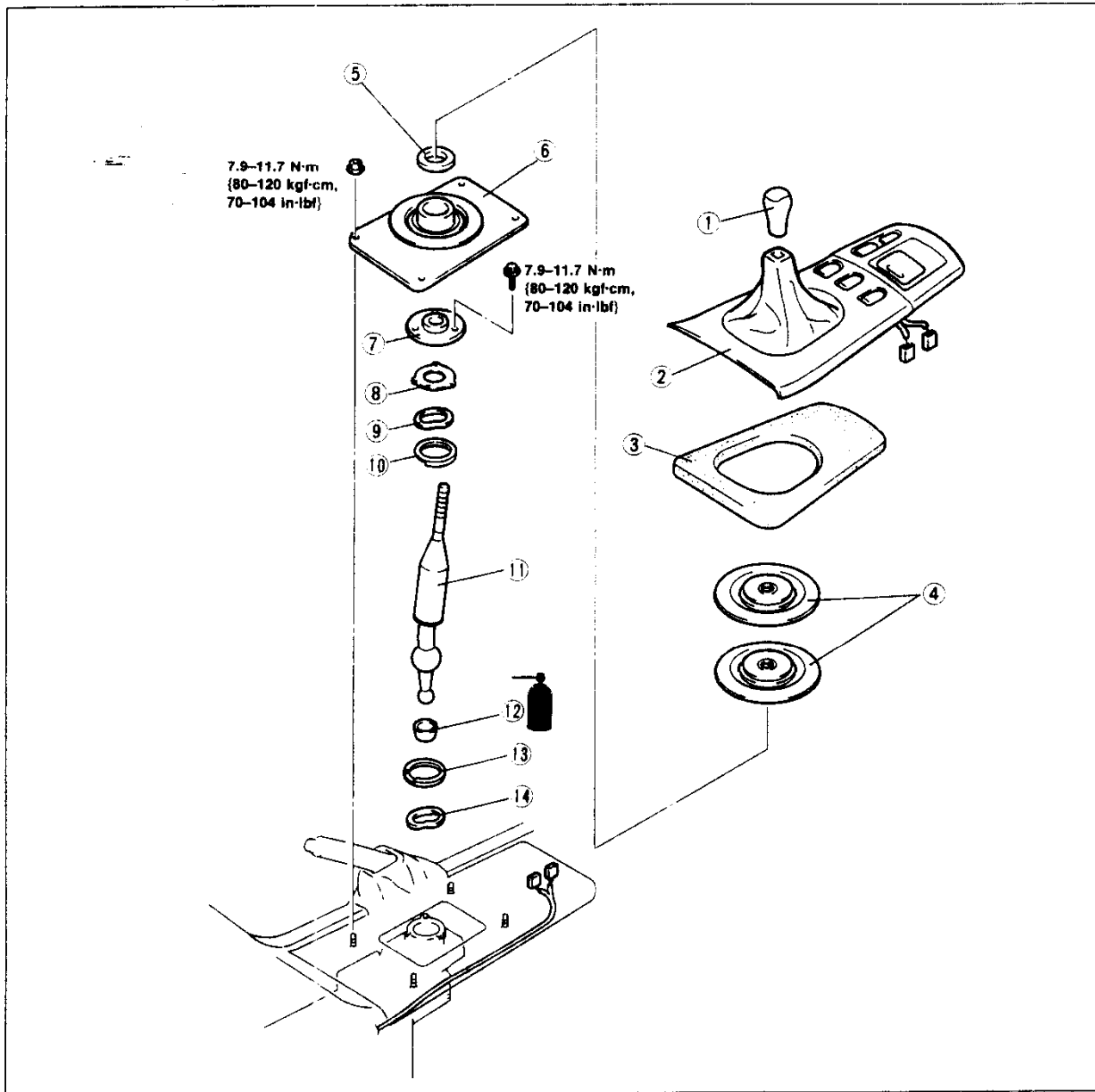

37U0JX-169

- 1. Shift lever knob
- 2. Console panel assembly
- 3. Bushing pad
- 4. Insulator boot pads
- 5. Insulator boot ring
- 6. Insulator boot
- 7. Dust boot

- 8. Gasket
- 9. Wave washer
- 10. Bushing
- 11. Shift lever
- Assembly Note
..... page J-62

- 12. Shift seat
- Assembly Note
..... page J-62
- 13. Bushing
- 14. Wave washer

J

SHIFT MECHANISM

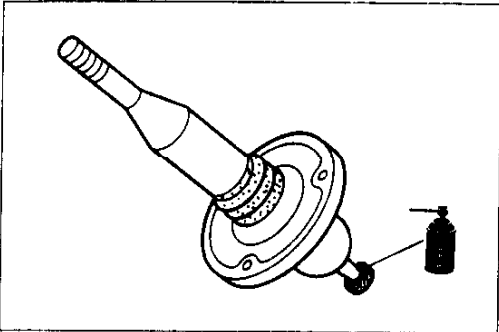

37U0JX-170

Assembly Note Shift seat

Apply grease to both the inside and outside of the shift seat.

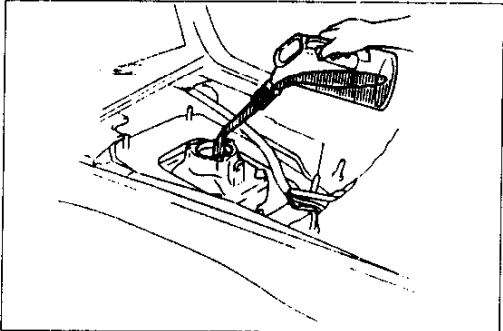

37U0JX-171

Shift lever

Note

- Fill the change control case with oil after removing the clutch housing or disassembling the transmission.

1. Fill the change control case with the specified oil.

Capacity: 80–95 cc {4.9–5.8 cu in}

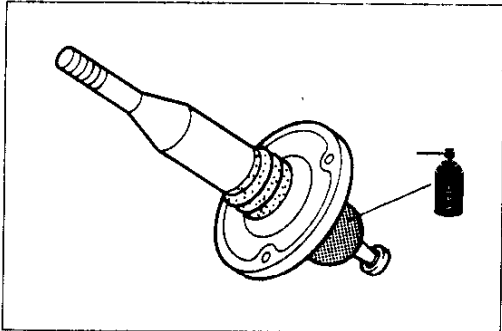

37U0JX-172

2. Apply grease to the shift lever ball joint.

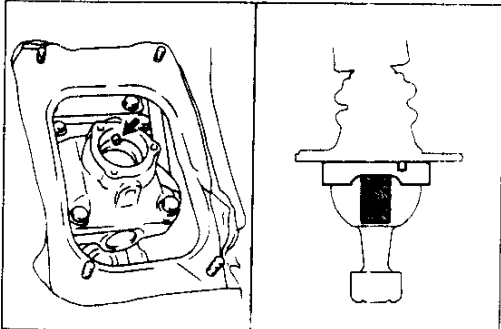

37U0JX-173

3. Align the control case pin with the slots in the change bushings and the shift lever, and install.