

THIS MANUAL IS AN ONLINE BACKUP TO YOUR  
**ORIGINAL HARDCOPY VERSION.**

RX7CITY.COM ASSUMES NO RESPONSIBILITY IN HOW YOU USE  
THIS MANUAL. THIS MANUAL IS FOR EXPERIENCED MECHANICS  
AND IS TO BE USED AT YOUR OWN RISK!



Before beginning any service procedure, refer to the 1993 RX-7 Body Electrical Troubleshooting Manual; see section S for air bag system precautions and J1 for audio anti-theft system precautions.

## CLUTCH

<b>INDEX</b> .....	H - 2
<b>OUTLINE</b> .....	H - 3
SPECIFICATIONS .....	H - 3
<b>TROUBLESHOOTING GUIDE</b> .....	H - 3
<b>CLUTCH FLUID</b> .....	H - 4
PREPARATION .....	H - 4
INSPECTION .....	H - 4
REPLACEMENT .....	H - 4
<b>CLUTCH PEDAL</b> .....	H - 6
ADJUSTMENT .....	H - 6
REMOVAL/INSTALLATION .....	H - 7
OVERHAUL .....	H - 8
<b>CLUTCH MASTER CYLINDER</b> .....	H - 9
PREPARATION .....	H - 9
REMOVAL/INSPECTION/ INSTALLATION .....	H - 9
AIR BLEEDING .....	H -11
OVERHAUL .....	H -12
<b>CLUTCH RELEASE CYLINDER</b> .....	H -14
PREPARATION .....	H -14
REMOVAL/INSPECTION/ INSTALLATION .....	H -14
OVERHAUL .....	H -15
<b>CLUTCH UNIT</b> .....	H -16
PREPARATION .....	H -16
REMOVAL/INSTALLATION .....	H -17
<b>CLUTCH COVER</b> .....	H -20
INSPECTION .....	H -20
<b>CLUTCH DISC</b> .....	H -21
INSPECTION .....	H -21
<b>CLUTCH RELEASE FORK ASSEMBLY</b> .....	H -21
INSPECTION .....	H -21
OVERHAUL .....	H -22
<b>CLUTCH RELEASE COLLAR</b> .....	H -23
INSPECTION .....	H -23
<b>PILOT BEARING</b> .....	H -23
INSPECTION .....	H -23
<b>FLYWHEEL</b> .....	H -23
INSPECTION .....	H -23

## INDEX

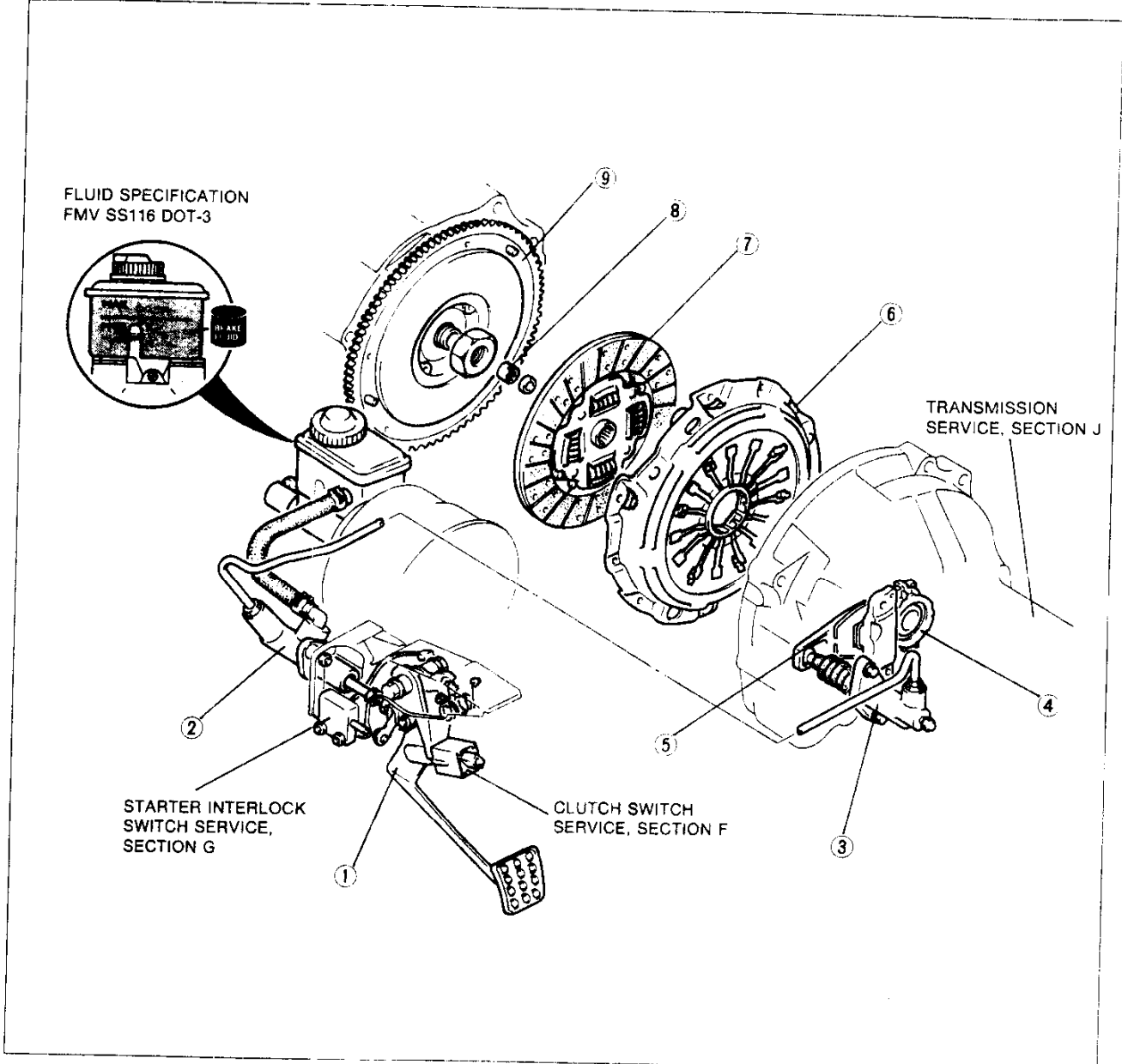

3710-HX-002

- |   |   |  |
|---|---|--|
| <p>1. Clutch pedal<br/>             Adjustment ..... page H- 6<br/>             Removal/<br/>             Installation ..... page H- 7<br/>             Overhaul ..... page H- 8</p> <p>2. Clutch master cylinder<br/>             Removal/Inspection/<br/>             Installation ..... page H- 9<br/>             Air bleeding .... page H-11<br/>             Overhaul ..... page H-12</p> <p>3. Clutch release cylinder<br/>             Removal/Inspection/<br/>             Installation ..... page H-14<br/>             Air bleeding .... page H-11<br/>             Overhaul ..... page H-15</p> | <p>4. Clutch release coil<br/>             Removal/<br/>             Installation ..... page H-17<br/>             Inspection ..... page H-23</p> <p>5. Clutch release fork assembly<br/>             Removal/<br/>             Installation ..... page H-17<br/>             Inspection ..... page H-21<br/>             Overhaul ..... page H-22</p> <p>6. Clutch cover<br/>             Removal/<br/>             Installation ..... page H-17<br/>             Inspection ..... page H-20</p> | <p>7. Clutch disc<br/>             Removal/<br/>             Installation ..... page H-17<br/>             Inspection ..... page H-21</p> <p>8. Pilot bearing<br/>             Removal/<br/>             Installation ..... page H-17<br/>             Inspection ..... page H-23</p> <p>9. Flywheel<br/>             Removal/<br/>             Installation ..... page H-17<br/>             Inspection ..... page H-23</p> |
|---|---|--|

OUTLINE

SPECIFICATIONS

Item		Transmission model	R15M-D (R5M-D)	
Clutch control			Hydraulic	
Clutch pedal	Type		Suspended	
	Pedal ratio		6.35	
	Full stroke	mm {in}	135 {5.32}	
	Height (with carpet)	mm {in}	165.5-177.0 {6.516-6.968}	
Clutch disc	Outer diameter	mm {in}	236 {9.29}	
	Inner diameter	mm {in}	160 {6.30}	
	Facing thickness	Flywheel side	mm {in}	3.5 {0.14}
		Pressure plate side	mm {in}	3.5 {0.14}
Clutch cover	Type		Diaphragm spring	
	Set load	N {kgf, lbf}	7.220 {736,1619}	
Clutch master cylinder	Inner diameter	mm {in}	15.87 {0.625}	
Clutch release cylinder	Inner diameter	mm {in}	19.05 {0.750}	
Clutch fluid			FMVSS116 DOT-3	

37U0HX-003

TRUBLESHOOTING GUIDE

Problem	Possible Cause	Action	Page
<b>Slipping</b>	Clutch disc facing worn excessively	Replace	H-17
	Clutch disc facing surface hardened or oil soaked	Repair or replace	H-17
	Pressure plate damaged	Replace	H-17
	Flywheel damaged	Replace	H-17
	Diaphragm spring damaged or weak	Replace	H-17
	Insufficient clutch pedal play	Adjust	H-6
	Clutch pedal sticking	Repair or replace	H-7, 8
<b>Faulty disengagement</b>	Clutch disc damaged or excessive runout	Replace	H-17
	Clutch disc splines rusted or worn	Repair or replace	H-17
	Oil on clutch disc facing	Repair or replace	H-17
	Diaphragm spring damaged or weak	Replace	H-17
	Excessive clutch pedal play	Adjust	H-6
	Leakage of clutch fluid	Locate and repair or replace	-
<b>Clutch vibrates when accelerating</b>	Oil on clutch disc facing	Repair or replace	H-17
	Clutch disc facing hardened or damaged	Repair or replace	H-17
	Diaphragm spring weak	Replace	H-17
	Clutch disc facing rivets loose	Replace	H-17
	Pressure plate damaged or excessive runout	Replace	H-17
	Flywheel surface hardened or damaged	Repair or replace	H-17
	Loose or worn engine mount	Tighten or replace	-
<b>Clutch pedal sticks</b>	Pedal shaft not properly lubricated	Lubricate or replace	H-8
<b>Abnormal noise</b>	Clutch release collar damaged	Replace	H-17
	Release collar not properly lubricated	Lubricate or replace	H-17
	Torsion spring weak	Replace	H-17
	Pilot bearing worn or damaged	Replace	H-17
	Worn pivot points of release fork	Repair or replace	H-17
	Release fork contact points not properly lubricated	Lubricate or replace	H-17
<b>Clutch pedal vibrates when engine running</b>	Improper installation of or damage to wedge collar and wire ring assembly	Replace	H-17

37U0HX-004

## CLUTCH FLUID

## PREPARATION

## SST

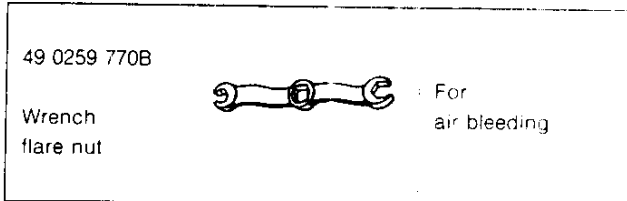

37U0HX-005

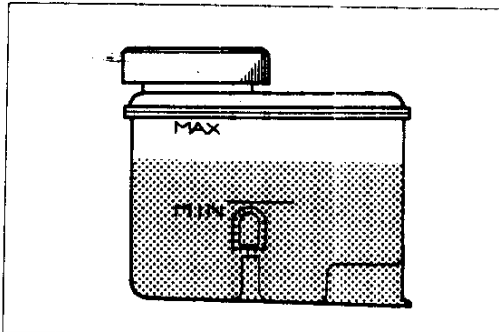

37U0HX-006

## INSPECTION

## Note

- A common reservoir is used for the clutch and brake system fluids.

1. Make sure that the fluid level in the reservoir is between the MAX and MIN mark.
2. If the fluid level is extremely low, check the clutch and brake systems for leakage.

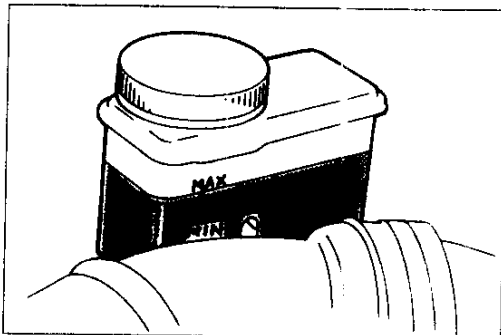

37U0HX-007

## REPLACEMENT

## Caution

- Be careful not to spill fluid on a painted surface. If this should happen, wash the surface off immediately.
- Use only the specified fluid. Avoid mixing different brands of fluid.
- Do not reuse old clutch fluid.
- The clutch and brakes draw fluid from the same reservoir; therefore draining the clutch fluid also drains the brake fluid from the reservoir.

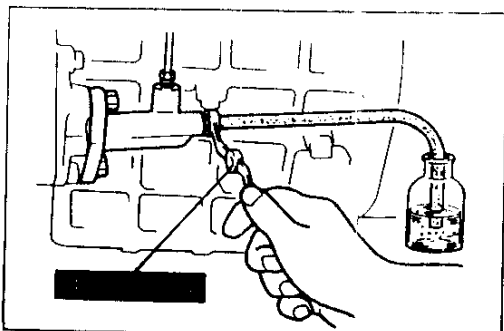

37U0HX-009

1. Drain the brake fluid from the reservoir by using a suction pump. (Refer to section P.)
2. Remove the bleeder cap from the clutch release cylinder and attach a vinyl hose to the bleeder plug.
3. Insert the other end of the vinyl hose into a clear container.
4. Loosen the bleeder screw by using the **SST**.
5. With another person slowly pumping the clutch pedal, drain the clutch fluid.
6. Repeat step 5 until all the fluid is drained.

7. Tighten the bleeder screw by using the **SST**.

**Caution**

- When tightening the bleeder screw with the SST, adjust the below-written tightening torque by using the following formulas. Choose the formula that applies to you.

(L = torque wrench length)

N·m	$N \cdot m \times L \text{ m} \div (L \text{ m} + 0.05)$
kgf·cm	$\text{kgf} \cdot \text{cm} \times L \text{ cm} \div (L \text{ cm} + 5.0)$
in·lbf	$\text{in} \cdot \text{lbf} \times L \text{ in} \div (L \text{ in} + 2.0)$

**Tightening torque:**

**5.9–8.8 N·m {60–90 kgf·cm, 53–78 in·lbf}**

8. Add fluid to the MAX mark.
9. Bleed the air from the clutch. (Refer to page H-11.)
10. Bleed the air from the brakes. (Refer to section P.)
11. Check for correct clutch operation.
12. Verify that there is no fluid leakage.

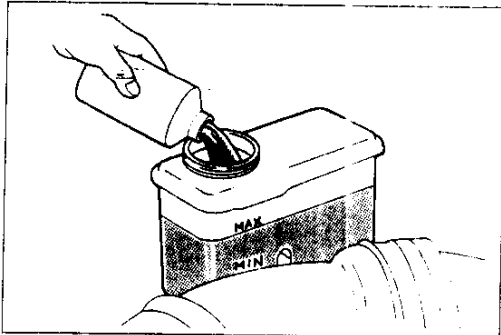

37J0HX 010



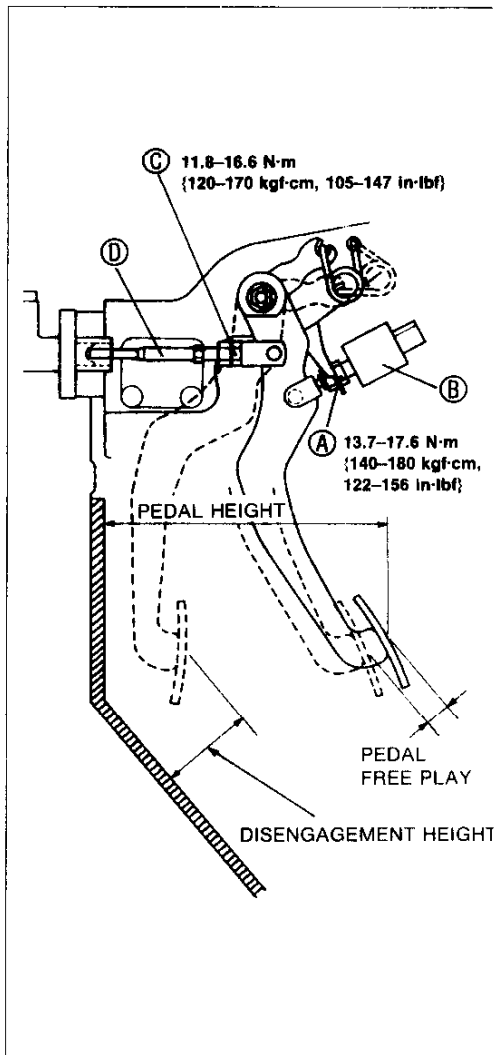

## CLUTCH PEDAL

### ADJUSTMENT

#### Clutch Pedal Height Inspection

Measure the distance from the upper surface of the pedal to the carpet.

**Pedal height: 165.5–177.0 mm {6.516–6.968 in} (with carpet)**

If necessary, adjust the pedal height.

#### Adjustment

1. Disconnect the clutch switch connector.
2. Loosen locknut A and turn clutch switch B until the pedal height is correct.
3. Tighten locknut A.

#### Tightening torque:

**13.8–17.6 N·m {140–180 kgf·cm 122–156 in·lbf}**

4. After adjustment, inspect the pedal free play.

#### Clutch Pedal Free Play Inspection

Depress the clutch pedal by hand until clutch resistance is felt.

**Pedal free play: 0.6–3.2 mm {0.02–0.13 in}**  
**Total pedal free play: 5.1–14 mm {0.20–0.55 in}**

If necessary, adjust the pedal free play.

#### Adjustment

1. Loosen locknut C and turn push rod D until pedal free play is correct.
2. Verify that the disengagement height from the upper surface of the pedal height to the carpet is correct when the pedal is fully depressed.

**Minimum disengagement height: 48 mm {1.9 in} (with carpet)**

3. Tighten locknut C.

#### Tightening torque:

**11.8–16.6 N·m {120–170 kgf·cm, 105–147 in·lbf}**

4. After adjustment, inspect the pedal height.

## REMOVAL / INSTALLATION

1. Remove in the order shown in the figure.
2. Install in the reverse order of removal.

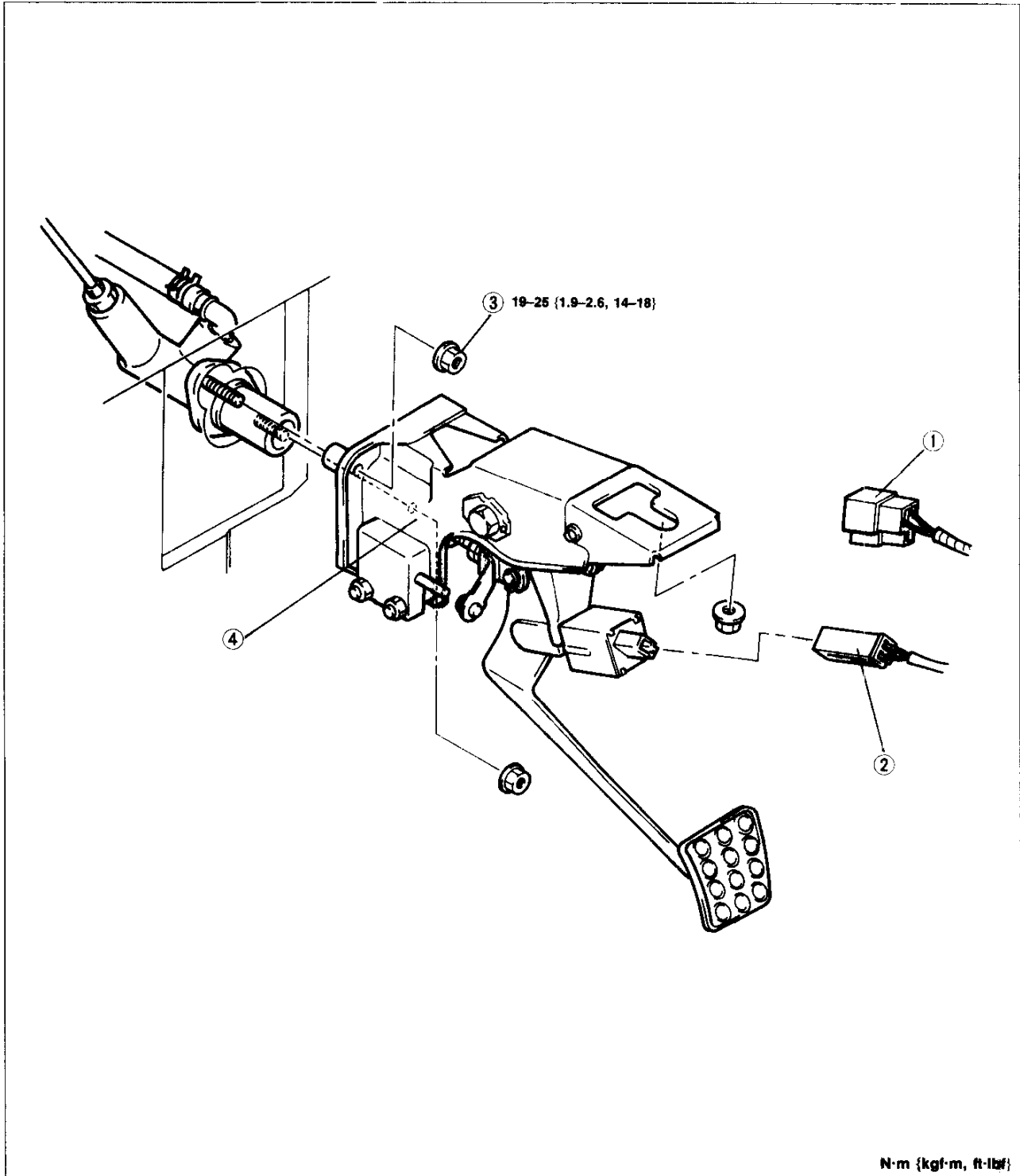

N·m {kgf·m, ft·lbf}

37U0HX-012

1. Starter interlock switch connector
2. Clutch switch connector

3. Nut

4. Clutch pedal assembly  
 Adjustment ..... page H-6  
 Overhaul ..... page H-8

# H

## CLUTCH PEDAL

### OVERHAUL

1. Disassemble in the order shown in the figure.
2. Inspect all parts and repair or replace as necessary.

#### Note

- Apply lithium-based grease to the spring, bushings, and pins when assembling.

3. Assemble in the reverse order of disassembly, referring to **Assembly Note**.

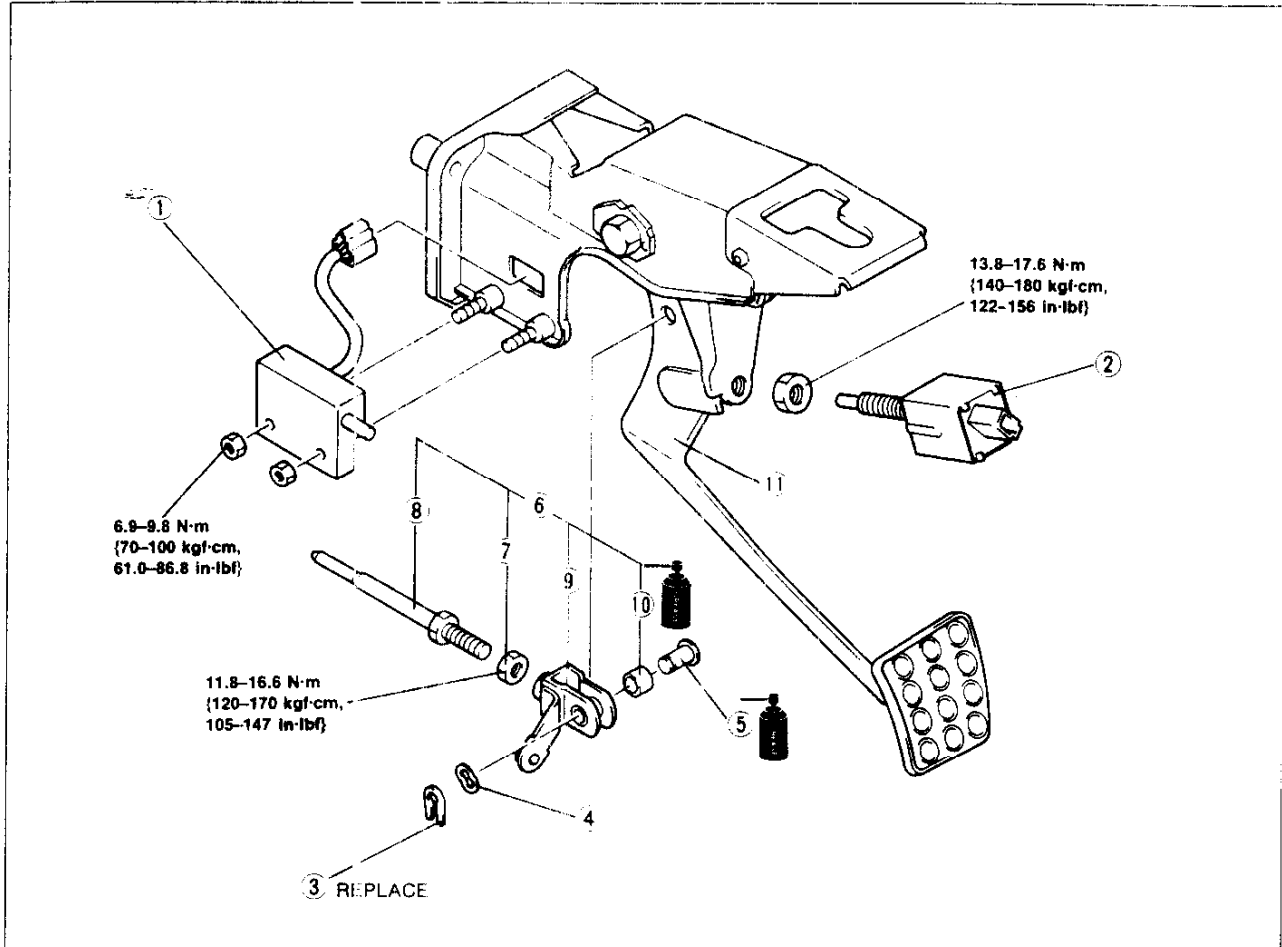

37U0-X-013

- |                             |  |                           |
|-----------------------------|--|---------------------------|
| 1. Starter interlock switch | 5. Pin   | 8. Push rod               |
| 2. Clutch switch            | 6. Push rod assembly<br>Inspect for damage and<br>bending. | 9. Fork                   |
| 3. Retaining ring           | 7. Nut   | 10. Spacer                |
| 4. Wave washer              |  | 11. Clutch pedal assembly |

CLUTCH MASTER CYLINDER

PREPARATION

SST

49 0259 770B		For disconnecting and connecting clutch pipe
--------------	---	--

37U0HX 014

REMOVAL / INSPECTION / INSTALLATION

Caution

- Clutch fluid will damage painted surfaces. Be sure to use a container or rags to collect it. If fluid gets on a painted surface, wipe it off immediately with a rag.

1. Remove in the order shown in the figure, referring to **Removal Note**.
2. Inspect all parts and repair or replace as necessary
3. Install in the reverse order of removal, referring to **Installation Note**.

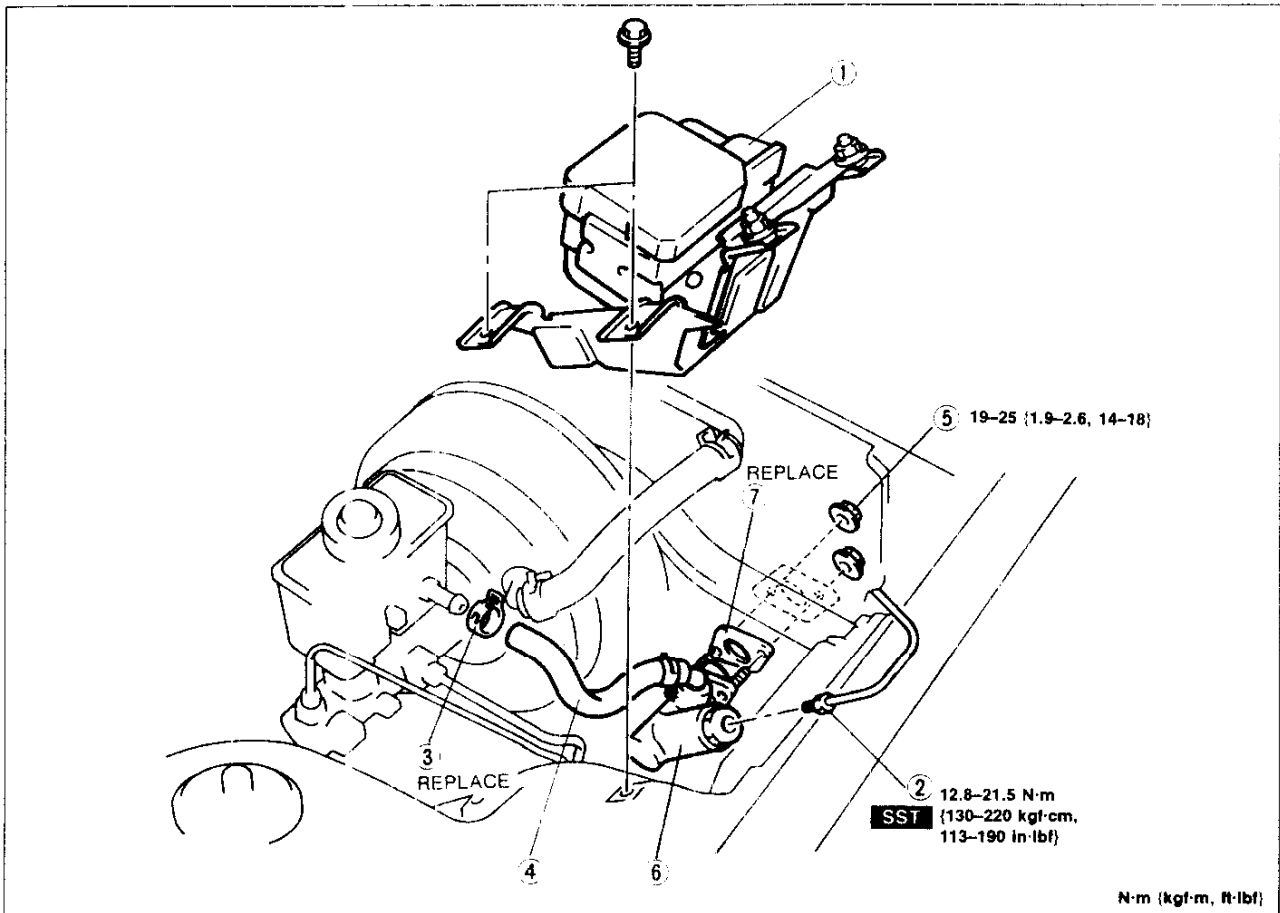

37U0HX-015

- |   |   |   |
|---|---|---|
| <p>1. Cruise control actuator assembly<br/>Removal Note ..... page H-10<br/>Installation Note ..... page H-10</p> | <p>3. Hose clamp<br/>4. Clutch hose<br/>Installation Note ..... page H-10</p> <p>5. Nut</p> | <p>6. Clutch master cylinder<br/>Overhaul ..... page H-12<br/>Inspect for fluid leakage from the cylinder bore<br/>Air bleeding .... page H-11</p> <p>7. Gasket</p> |
|---|---|---|

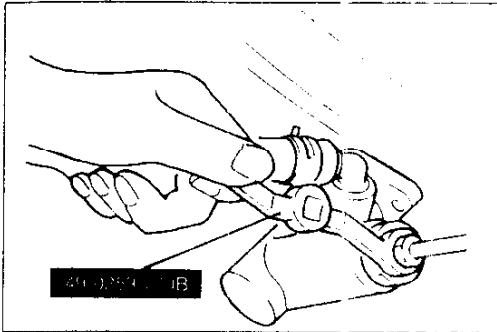

37U0HX-016

### Removal Note Clutch pipe

#### Caution

- Clutch fluid will damage painted surfaces. If fluid does get on a painted surface, wipe it off immediately with a rag.

1. Disconnect the clutch pipe by using the **SST**

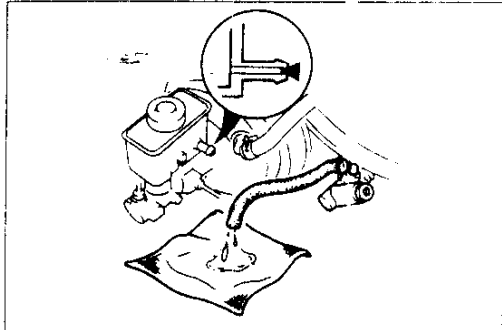

37J00X-017

2. Disconnect the clutch hose from the reservoir.
3. Plug the outlet of the reservoir.

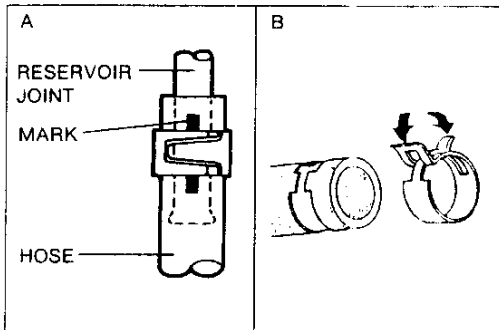

37U0HX-018

### Installation Note Clutch hose

#### Caution

- Install the clutch hose with the mark facing upward, as shown in figure A.
- If reusing the clutch hose, install the new hose clamp exactly into the mark left by the previous hose clamp, as shown in figure B.
- Squeeze the clamp lightly with large pliers to ensure a good fit.

### Clutch pipe

Tighten the clutch pipe by using the **SST**.

#### Caution

- Before tightening the clutch pipe with the SST, refer to the formulas on page H-5 to calculate the required torque.

#### Tightening torque:

12.8–21.5 N·m {130–220 kgf·cm, 113–190 in·lbf}

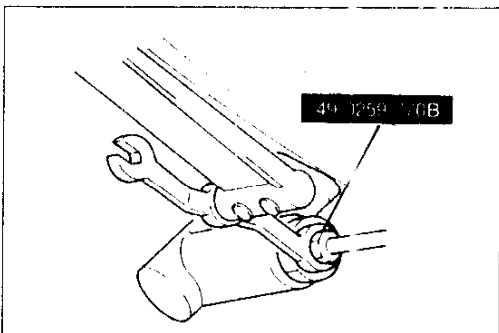

37U0HX-019

### After-installation Procedure

1. Bleed the clutch system. (Refer to page H-11.)
2. Add fluid to the reservoir MAX mark.
3. Inspect and adjust the clutch pedal height and free play. (Refer to page H-6.)

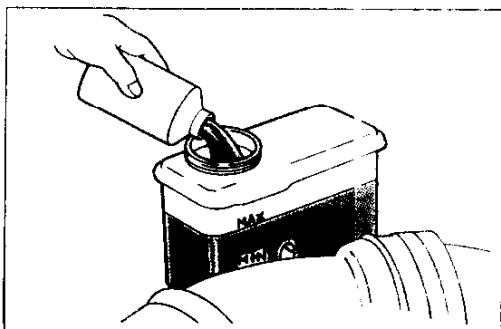

37U0HX-020

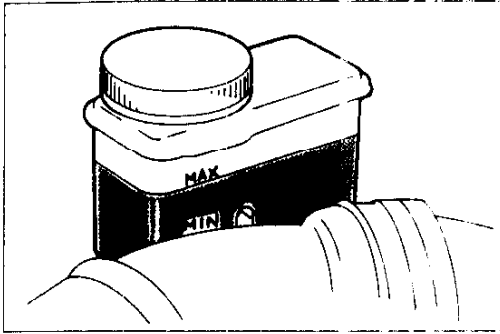

37U0HX-022

## AIR BLEEDING

The clutch hydraulic system must be bled to remove air introduced whenever a hydraulic line is disconnected.

### Note

- The fluid in the reservoir must be maintained at the 3/4 level or higher during air bleeding.

### Caution

- Be careful not to spill fluid on a painted surface. If this should happen, wash the surface off immediately.
- Use only the specified fluid. Avoid mixing different brands of fluid.
- Do not reuse clutch fluid.

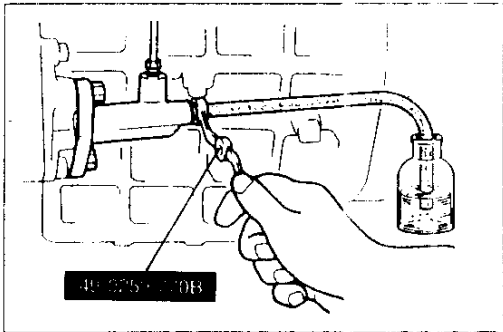

37U0HX-022

- 1 Remove the bleeder cap from the clutch release cylinder and attach a vinyl hose to the bleeder plug.
- 2 Insert the other end of the vinyl hose in a fluid-filled clear container.
- 3 With another person slowly pumping the clutch pedal, use the **SST** to loosen the bleeder screw to let fluid and air escape. Close the bleeder screw.
- 4 Repeat step 3 until no air bubbles are seen in the fluid.

### Caution

- Before tightening the bleeder screw with the **SST**, refer to the formulas on page H-5 to calculate the required torque.

- 5 Tighten the bleeder screw by using the **SST**.

### Tightening torque:

5.9–8.8 N·m {60–90 kgf·cm, 53–78 in·lbf}

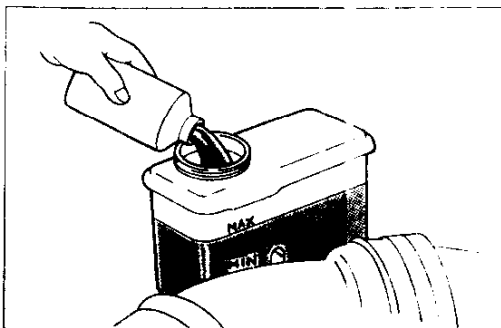

37U0HX-023

- 6 Add fluid to the MAX mark.
- 7 Check for correct clutch operation.
- 8 Verify that there is no fluid leakage.
- 9 Verify that the brakes function properly. (Refer to section P.)

# H

## CLUTCH MASTER CYLINDER

### OVERHAUL

#### Caution

- Clean the disassembled parts in solvent and blow through all ports and passages with compressed air. Before assembling, coat the piston secondary cup and the cylinder bore with clean fluid, and make sure there are no dust or particles in or on any of the parts.

1. Disassemble in the order shown in the figure, referring to **Disassembly Note**.
2. Inspect all parts and repair or replace as necessary.
3. Assemble in the reverse order of disassembly, referring to **Assembly Note**.

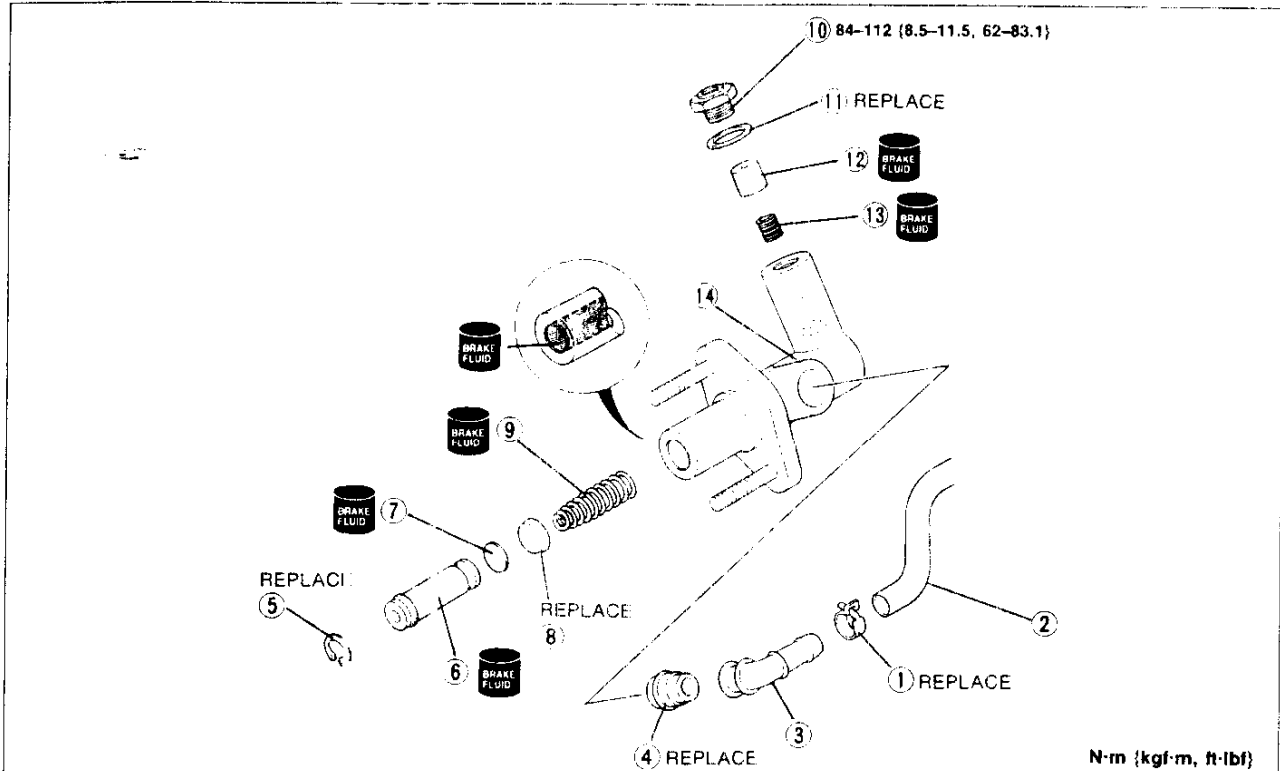

37U0HX-024

1. Hose clamp
2. Clutch hose
3. Joint
4. Bushing
5. Snap ring

Disassembly Note ..... below  
 Assembly Note ..... page H-13

6. Piston and secondary cup assembly  
 Disassembly Note ..... page H-13  
 Inspect for wear, scoring, and cracks  
 Assembly Note ..... page H-13
7. Spacer

8. Primary cup  
 Inspect for wear and cracks
9. Return spring
10. Joint bolt
11. Packing  
 Disassembly Note ..... page H-13
12. One-way valve piston  
 Disassembly Note ..... page H-13
13. Return spring
14. Master cylinder body  
 Inspect for scoring and corrosion.  
 Replace master cylinder assembly if any  
 scoring or corrosion is found.

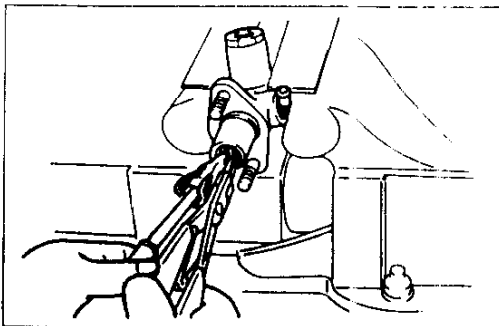

#### Disassembly Note

##### Snap ring

#### Caution

- Do not damage the push rod contact surface of the piston.

Press down on the piston by using a cloth-wrapped Phillips screwdriver, and remove the snap ring.

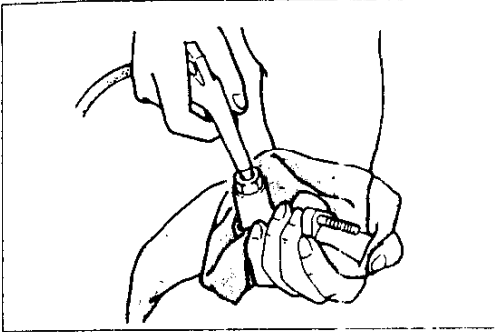

37U0HX-024

**Piston and secondary cup assembly****Caution**

- Hold a rag over the master cylinder to prevent the piston and secondary cup assembly from jumping out.

Remove the piston and secondary cup assembly, spacer, primary cup, and the return spring by applying compressed air through the clutch pipe installation hole.

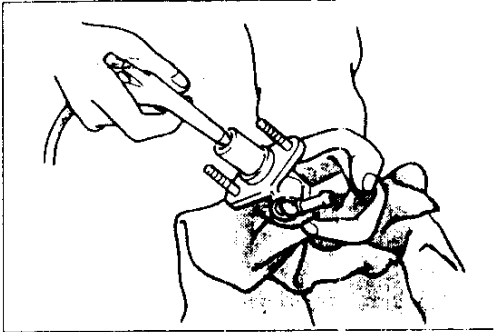

37U0HX-025

**One-way valve piston****Caution**

- Hold a rag over the master cylinder to prevent the piston and spring from jumping out.

Remove the piston by applying compressed air through the cylinder bore.

**Assembly Note****Caution**

- Before assembly, make sure all parts are completely clean.
- Use only the specified clutch fluid. Avoid mixing different brands of clutch fluid.
- Do not reuse clutch fluid.
- Apply the specified clutch fluid to the piston and secondary cup assembly, spacer, primary cup, and cylinder bore before assembly.
- Replace parts with new ones whenever specified.

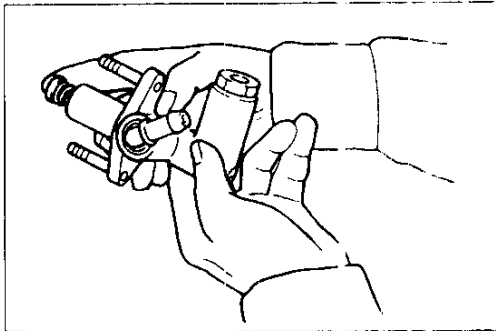

37U0HX-027

**Piston and secondary cup assembly**

Install the spring, primary cup, spacer, and piston and secondary cup assembly, noting the proper direction of the parts.

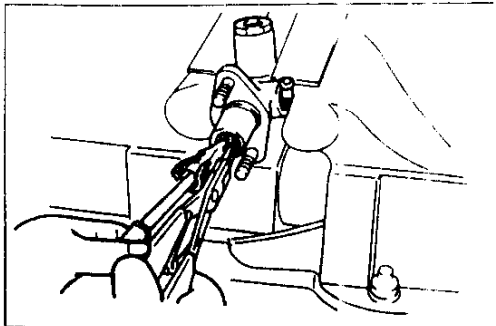

37U0HX-028

**Snap ring****Caution**

- Do not damage the pushrod contact surface of the piston.

Press down on the piston with a cloth-wrapped Phillips screwdriver, and install the snap ring.

### CLUTCH RELEASE CYLINDER

#### PREPARATION

##### SST

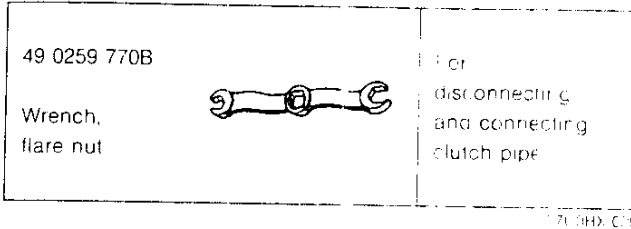

#### REMOVAL / INSPECTION / INSTALLATION

##### Caution

- Clutch fluid will damage painted surfaces. If fluid does get on a painted surface, wipe it off immediately with a rag.

1. Remove in the order shown in the figure, referring to **Removal Note**.
2. Inspect all parts and repair or replace as necessary.
3. Install in the reverse order of removal, referring to **Installation Note**.

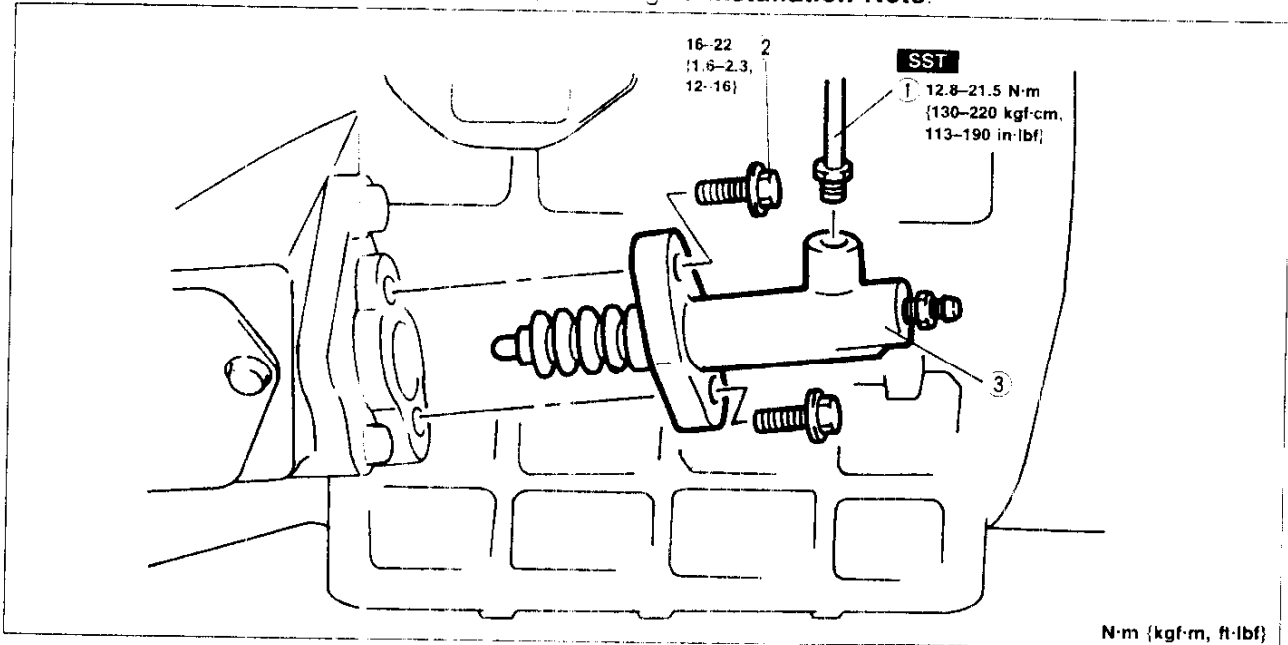

- |   |  |
|---|--|
| <ol style="list-style-type: none"> <li>1. Clutch pipe<br/>Removal Note ..... below<br/>Installation Note ..... page H-15</li> </ol> | <ol style="list-style-type: none"> <li>2. Bolt</li> <li>3. Clutch release cylinder<br/>Remove boot and check for fluid leakage<br/>Overhaul ..... page H-15</li> </ol> |
|---|--|

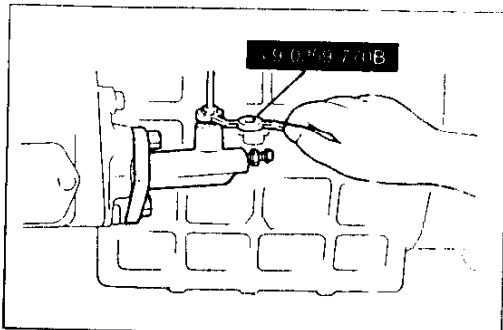

#### Removal Note Clutch pipe

##### Caution

- Plug the clutch pipe after removing, to avoid fluid leakage.

Disconnect the clutch pipe from the clutch release cylinder by using the **SST**.

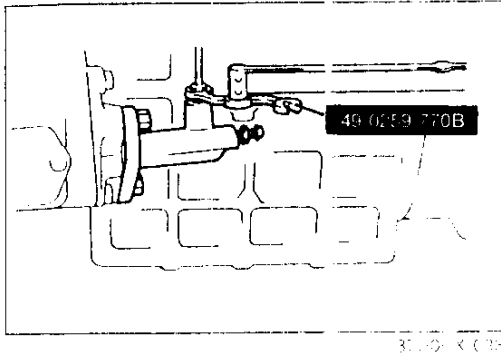

### Installation Note Clutch pipe

#### Caution

- Before tightening the clutch pipe with the SST, refer to the formulas on page H-5 to calculate the required torque.

Tighten the clutch pipe onto the clutch release cylinder.

#### Tightening torque:

12.8–21.5 N·m {130–220 kgf·cm, 113–190 in·lbf}

### Air Bleeding

After installation, bleed the clutch system.  
(Refer to page H-11.)

## OVERHAUL

### Caution

- Clean the disassembled parts in solvent and blow through all ports and passages with compressed air.
- Before assembly, make sure all parts are completely clean.
- Apply the specified clutch fluid to the piston and cup assembly and cylinder bore before assembly.

1. Disassemble in the order shown in the figure, referring to **Disassembly Note**.
2. Inspect all parts and repair or replace as necessary.
3. Assemble in the reverse order of disassembly.

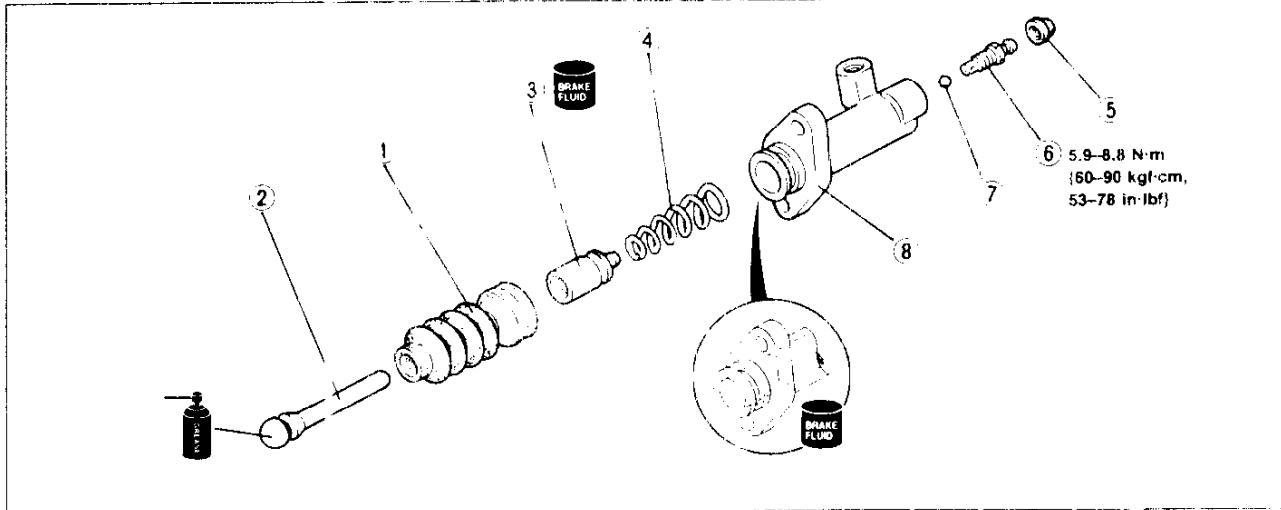

1. Boot
2. Push rod
3. Piston and cup assembly  
Disassembly Note ..... page H-16  
Inspect for wear, scoring and cracks
4. Return spring

5. Bleeder cap
6. Bleeder screw  
5.9–8.8 N·m  
(60–90 kgf·cm,  
53–78 in·lbf)
7. Steel ball
8. Release cylinder body  
Inspect cylinder bore for scoring and corrosion  
Replace cylinder assembly if any is found

# H

## CLUTCH RELEASE CYLINDER, CLUTCH UNIT

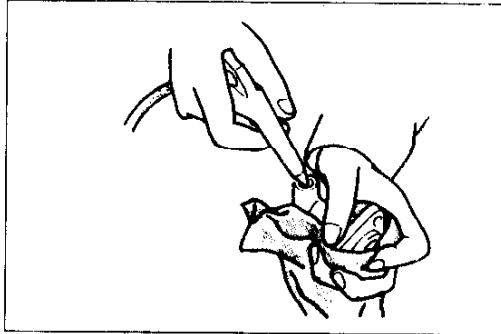

37U0HX-035

### Disassembly Note Piston and cup assembly

#### Caution





- Hold a rag over the release cylinder to prevent the piston and cup assembly from jumping out.

Remove the piston and cup assembly by applying compressed air through the clutch pipe installation hole.

## CLUTCH UNIT

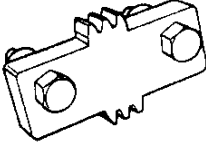
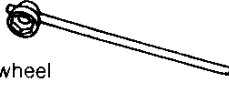
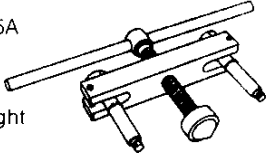
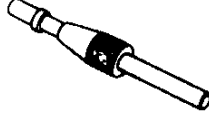
### PREPARATION

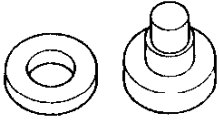
#### SST

<p>49 F011 101 Brake, ring gear</p> 	<p>For prevention of engine rotation</p>	<p>49 0820 035 Box wrench, flywheel</p> 	<p>For removal and installation of flywheel</p>
<p>49 0839 305A Puller, counterweight</p> 	<p>For removal of flywheel</p>	<p>49 SE01 310A Clutch disc centering tool</p> 	<p>For support of clutch disc</p>
<p>49 1285 071 Puller, bearing</p> 	<p>For removal of pilot bearing and oil seal</p>	<p>49 1285 073 Chuck (Part of 49 1285 071)</p> 	<p>For removal of pilot bearing and oil seal</p>
<p>49 F011 1A1 Installer set, bearing</p> 	<p>For installation of pilot bearing and oil seal</p>	<p>49 G030 795 Installer, oil seal</p> 	<p>For installation of pilot bearing and oil seal</p>
<p>49 G030 797 Handle (Part of 49 G030 795)</p> 	<p>For installation of pilot bearing and oil seal</p>		

37U0HX-036

## REMOVAL / INSTALLATION

### Note

- Remove the clutch release cylinder with the clutch pipe connected.
- Do not remove the pilot bearing unless necessary.

1. Remove in the order shown in the figure, referring to **Removal Note**.
2. Install in the reverse order of removal, referring to **Installation Note**.

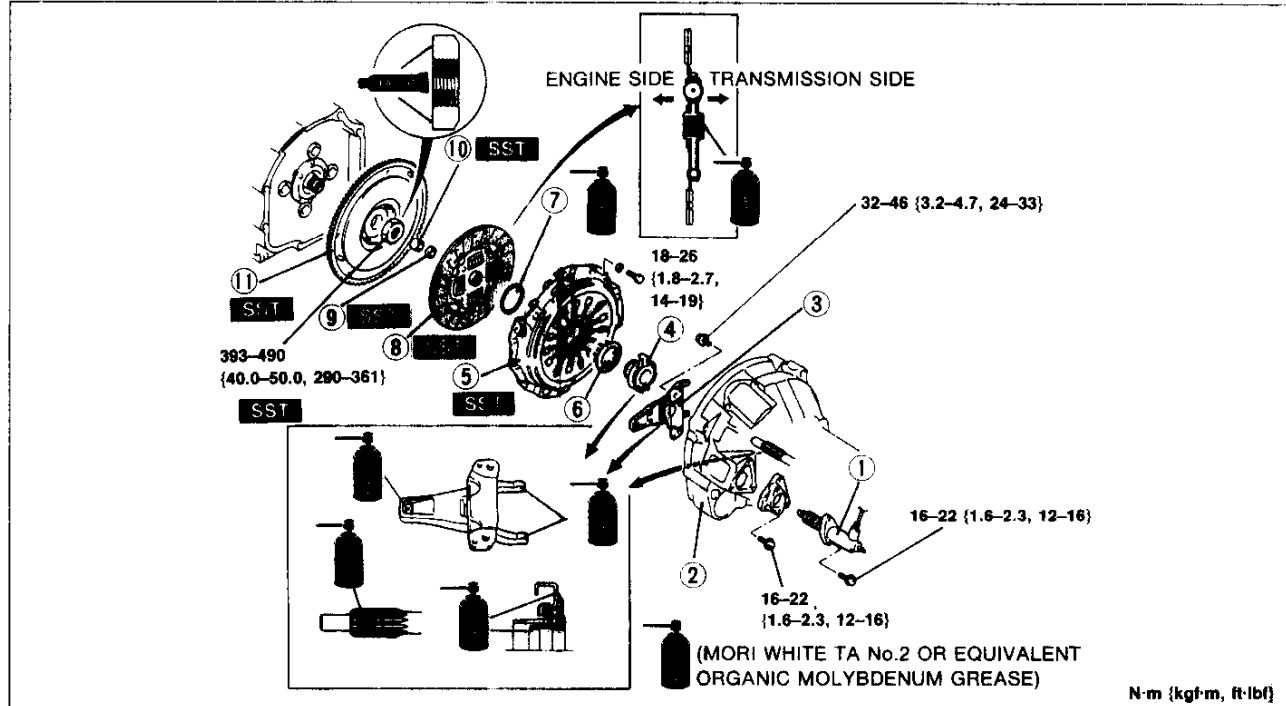

1. Clutch release cylinder
2. Transmission  
Service ..... section J
3. Clutch release fork assembly  
Removal Note ..... below  
Inspection ..... page H-21  
Overhaul ..... page H-22
4. Clutch release collar  
Removal Note ..... below  
Inspection ..... page H-23
5. Clutch cover  
Removal Note  
..... page H-18  
Inspection ..... page H-20  
Installation Note  
..... page H-20

6. Wedge collar  
Removal Note  
..... page H-18  
Installation Note  
..... page H-19
7. Wire ring
8. Clutch disc  
Removal Note  
..... page H-18  
Inspection ..... page H-21  
Installation Note  
..... page H-20
9. Oil seal  
Removal Note  
..... page H-18  
Installation Note  
..... page H-19

10. Pilot bearing  
Removal Note  
..... page H-18  
Inspection ..... page H-23  
Installation Note  
..... page H-19
11. Flywheel  
Removal Note  
..... page H-18  
Inspection ..... page H-23  
Installation Note  
..... page H-19

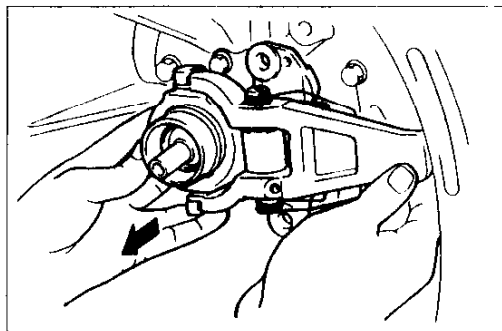

37U0HX-0-8

### Removal Note

#### Clutch release fork assembly and clutch release collar

1. Remove the release fork assembly bolts.
2. Remove the release fork assembly and release collar together as shown in the figure.

## CLUTCH UNIT

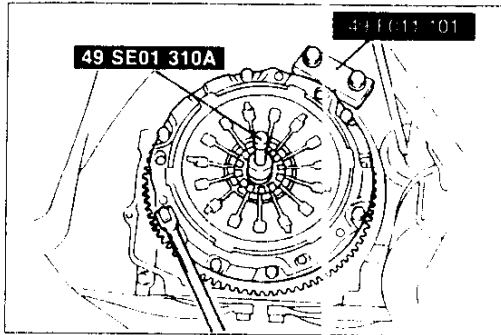

37-00-K-03E

### Clutch cover and disc

1. Install the **SST**.
2. Loosen each bolt one turn each in a crisscross pattern until spring tension is released.
3. Remove the clutch cover and disc.

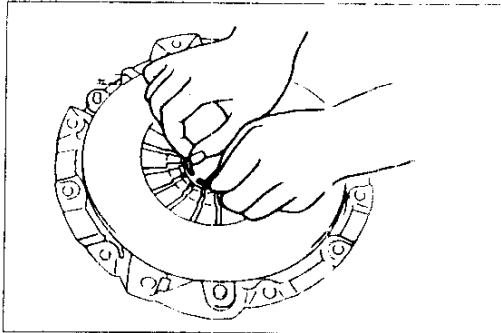

37-00-K-03F

### Wedge collar

#### Caution

- Do not reuse the wire ring or the wedge collar.

1. Remove the wire ring from the wedge collar.
2. Remove the wedge collar from the clutch cover.

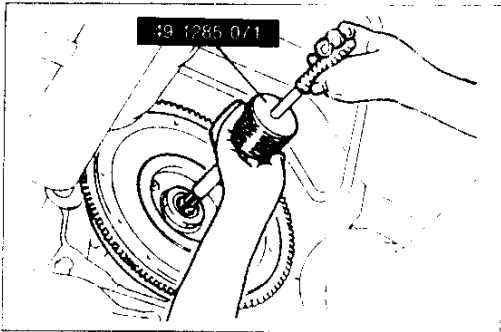

37-00-K-03G

### Oil seal and pilot bearing

Remove the pilot bearing together with the oil seal by using the **SST**.

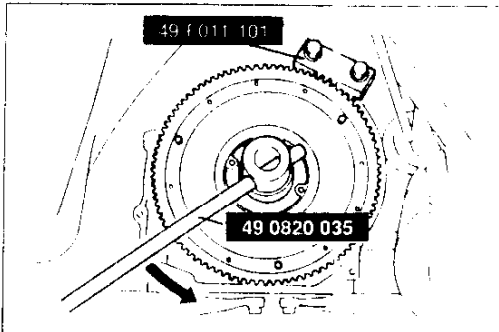

37-00-K-03H

### Flywheel

1. Hold the flywheel by using the **SST**.
2. Remove the locknut by using the **SST**.

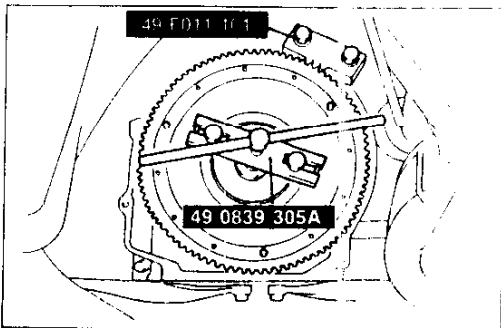

37-00-K-04

#### Note

- After removing the flywheel, inspect for oil leakage past the crankshaft rear oil seal.
- If necessary, replace the oil seal. (Refer to section C.)

3. Remove the flywheel by using the **SST**.
4. Remove the key from the eccentric shaft.

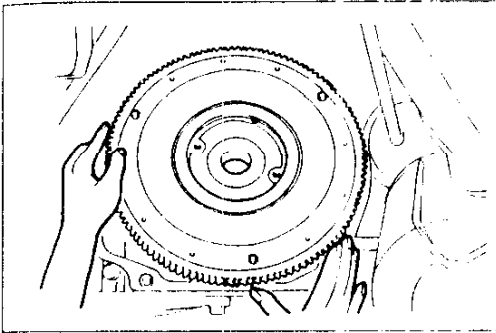

37UHX 044

## Installation Note Flywheel

1. Set the key in the eccentric shaft.
2. Align the groove with the eccentric shaft key and slide the flywheel into place.

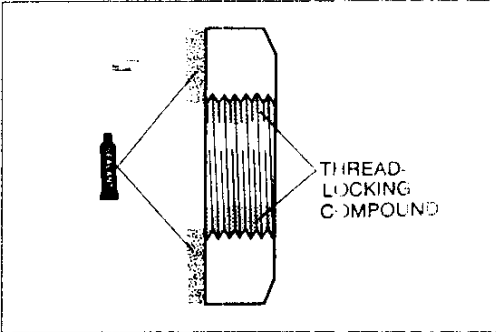

37UHX 044

3. Apply a small amount of sealant and thread-locking compound to the flywheel locknut as shown.

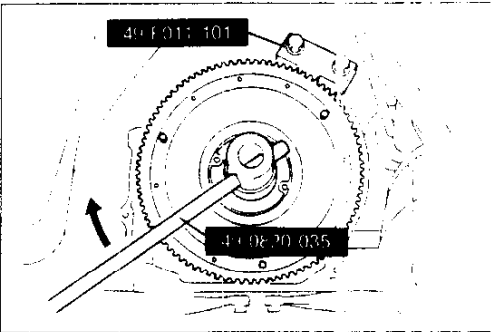

37UHX 044

4. Install the **SST** to the flywheel.
5. Tighten the locknut by using the **SST**.

### Tightening torque:

**393–490 N·m {40.0–50.0 kgf·m, 290–361 ft·lbf}**

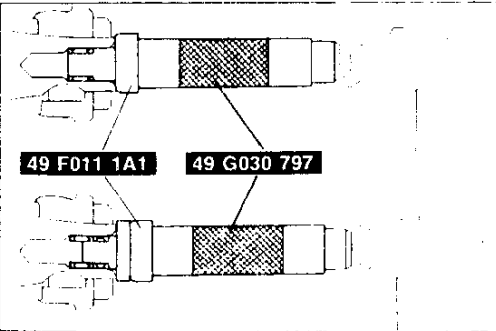

37UHX 044

## Pilot bearing and oil seal

1. Install the new bearing by using the **SST**.

**Bearing outer diameter: 20 mm {0.79 in}**

**Insertion depth: 11.5–12.3 mm {0.453–0.482 in}**

2. Install the new oil seal by using the **SST**.

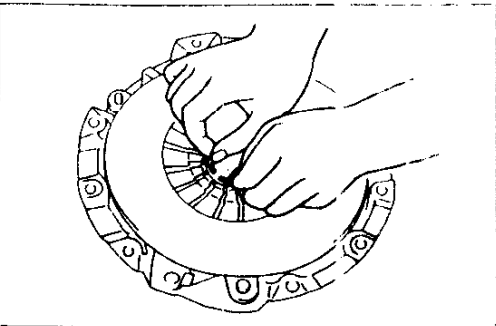

37UHX 047

## Wedge collar

### Caution

- Do not deform the wedge collar or wire ring when installing.

1. Install a new wedge collar to the clutch cover.
2. Apply a small amount of grease to a new wire ring and install into exact position.

# H

## CLUTCH UNIT, CLUTCH COVER

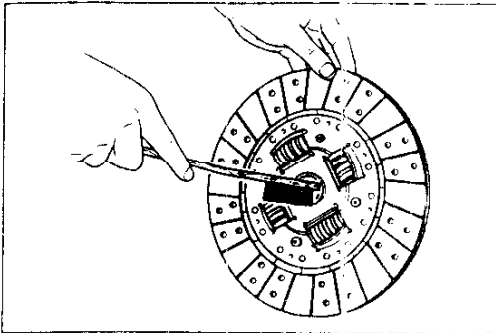

### Clutch disc

- 1 Clean the clutch disc splines and main drive gear splines. Apply molybdenum sulfide grease to the splines.

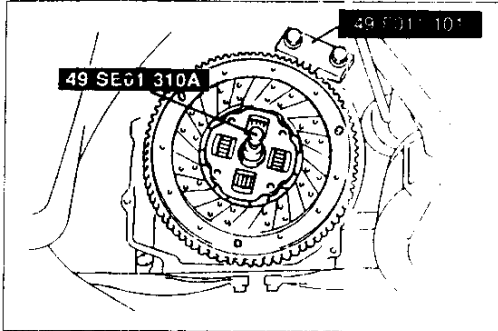

- 2 Hold the flywheel by using the **SST**.
- 3 Hold the clutch disc in position by using the **SST**.

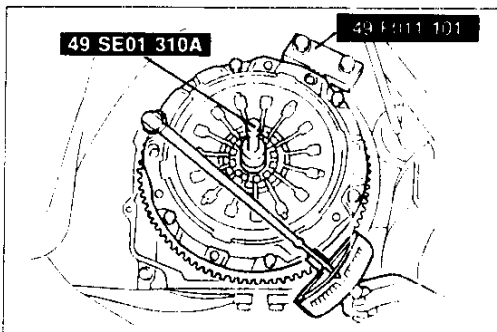

### Clutch cover

#### Caution

- Do not damage the wedge collar when installing the clutch cover.

- 1 Align the dowel holes with the flywheel dowels and set the clutch cover in place.
- 2 Tighten the bolts evenly and gradually in a crisscross pattern, while securing the flywheel by using the **SST**.

#### Tightening torque:

18–26 N·m {1.8–2.7 kgf·m, 14–19 ft·lbf}

## CLUTCH COVER INSPECTION

#### Caution

- Inspect for wear and damage, and replace if necessary.

- 1 Inspect for wear or damage to the wire ring contact surface of the diaphragm spring plate.
- 2 Inspect for loosening of the diaphragm spring plate support.
- 3 Measure the flatness of the pressure plate/clutch disc contact surface in a crisscross pattern with a straight-edge and a feeler gauge.

**Maximum: 0.20 mm {0.008 in}**

- 4 Check for discoloration of the pressure plate/clutch disc contact surface.

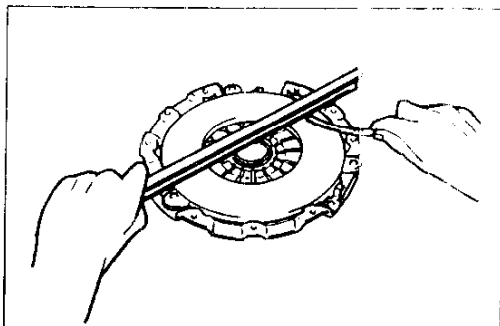
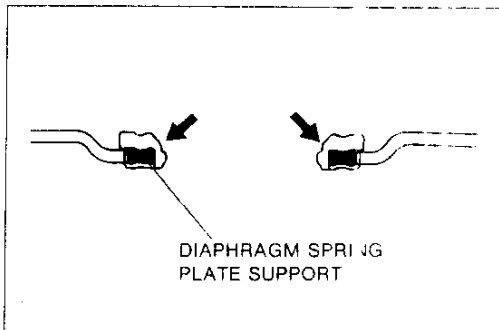

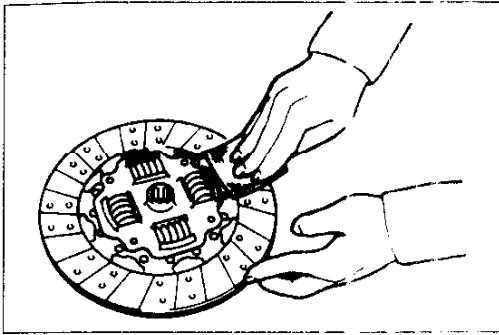

3710-X-53

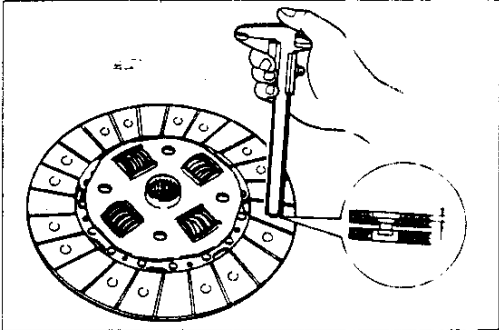

3710-X-54

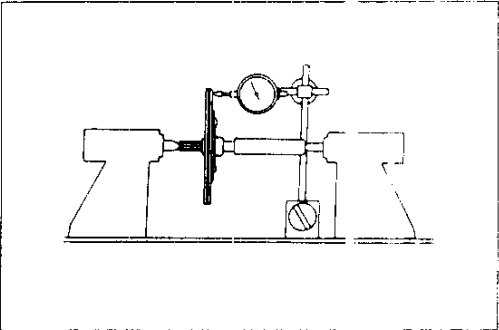

3710-X-55

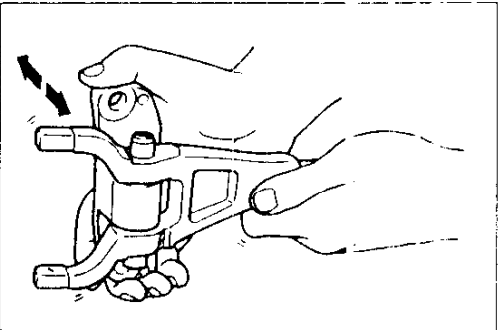

3710-X-56

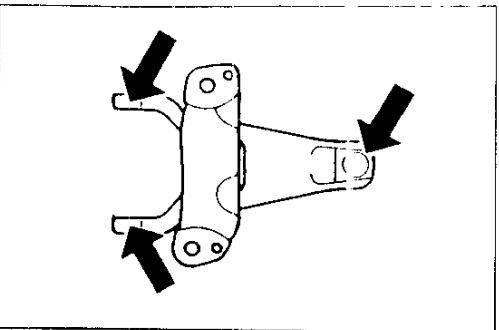

3710-X-57

## CLUTCH DISC

### INSPECTION

**Caution**

- Inspect for wear and damage, and replace if necessary.

1. Inspect the lining surface for burning or oil contamination. Remove minor scratches or discoloration with sandpaper.
2. Inspect for loose facing rivets and torsion springs. Replace the clutch disc if any are loose.
3. Measure the thickness of the lining at a rivet head on both sides with vernier calipers.

**Thickness: 0.3 mm {0.012 in} min.**

4. Measure the clutch disc runout with a dial indicator. Replace the clutch disc if runout is excessive.

**Runout: 0.6 mm {0.024 in} max.**

## CLUTCH RELEASE FORK ASSEMBLY

**Caution**

- Remove the return spring before inspection.

### INSPECTION

1. Swing the release fork back and forth, and make sure it moves smoothly.
2. Inspect for wear and damage to the push rod contact surface.
3. Inspect for wear and damage to the release collar contact surfaces.
4. Replace parts as necessary.

# H

## CLUTCH RELEASE FORK ASSEMBLY

### OVERHAUL

1. Disassemble in the order shown.
2. Inspect all parts and replace as necessary.
3. Assemble in the reverse order of disassembly, referring to **Assembly Note**.

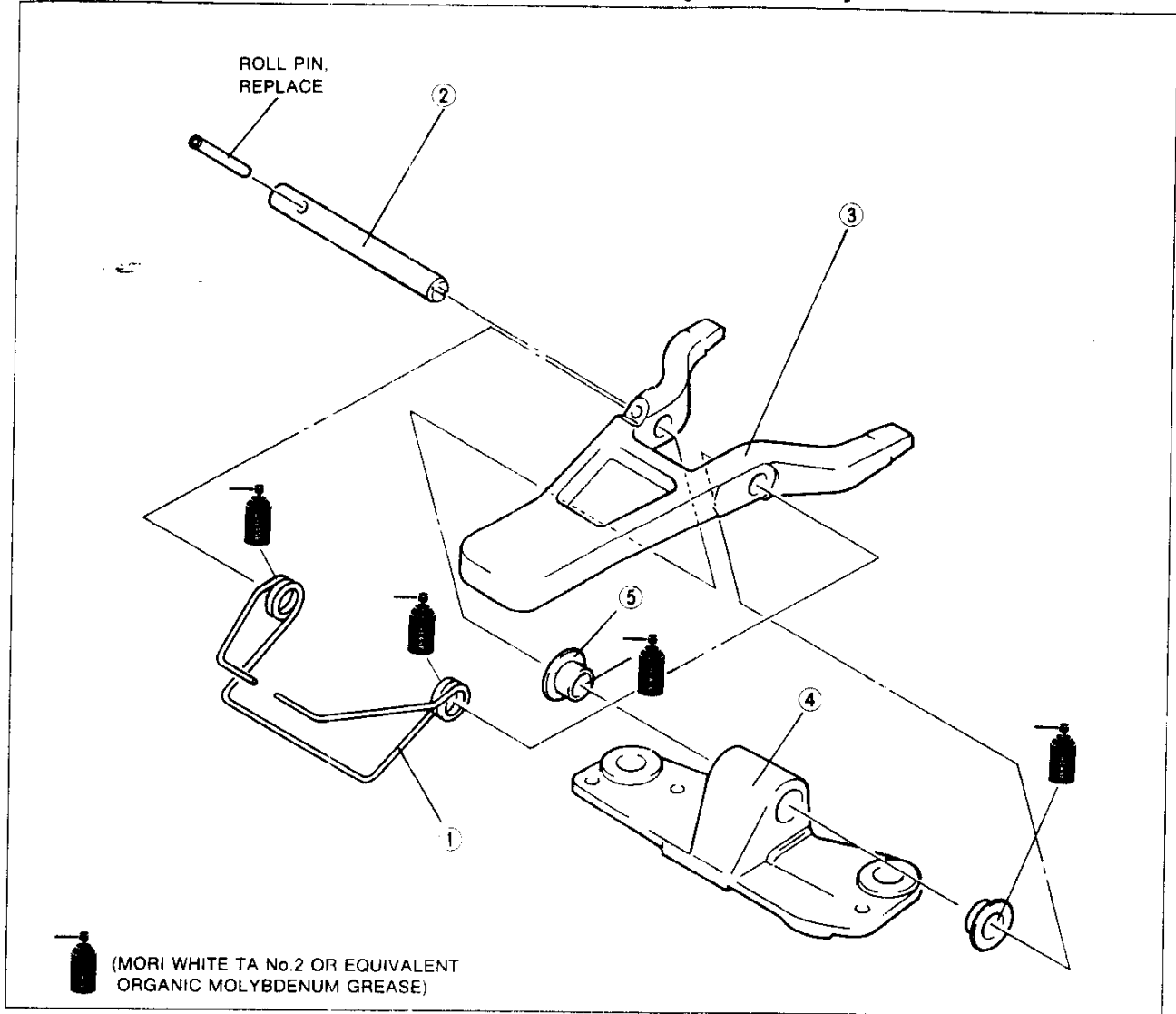

1. Return spring  
Inspect for damage and bending
2. Fork shaft  
Assembly Note ..... below

3. Clutch release fork  
Inspect for wear and damage
4. Release fork support

5. Bushing  
Inspect bushing bore for wear and damage

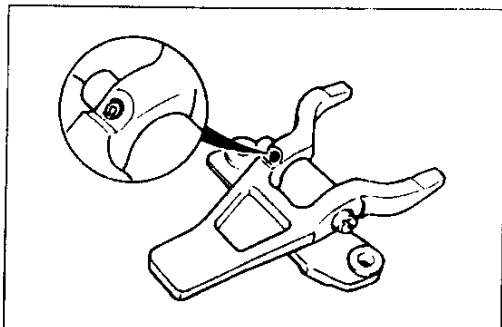

### Assembly Note Fork shaft

1. Install the roll pin with the split facing as shown.
2. Make sure the roll pin is installed flush with the release fork surface.

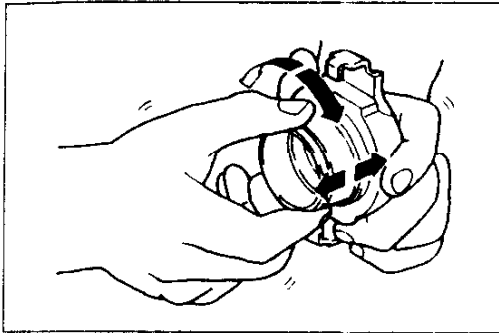

37J0HX-060

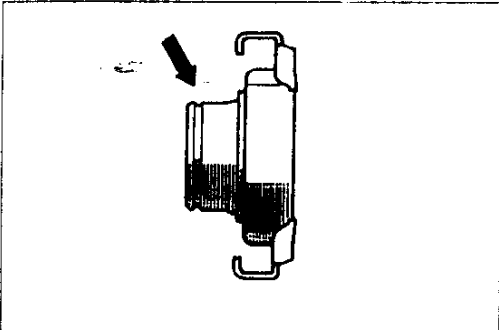

37U0HX-061

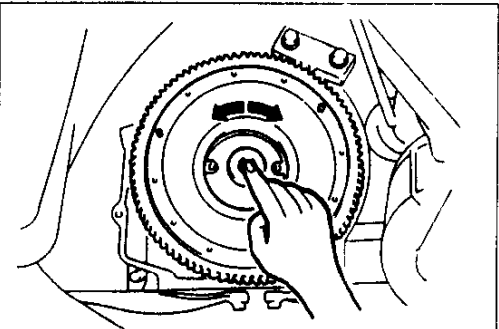

37U0HX-062

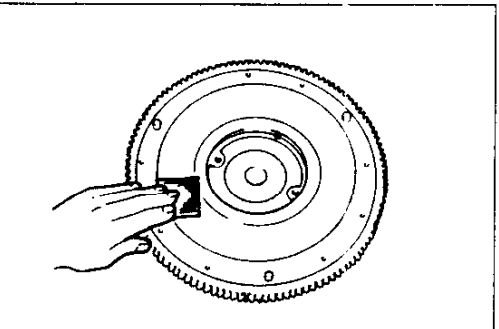

37U0HX-063

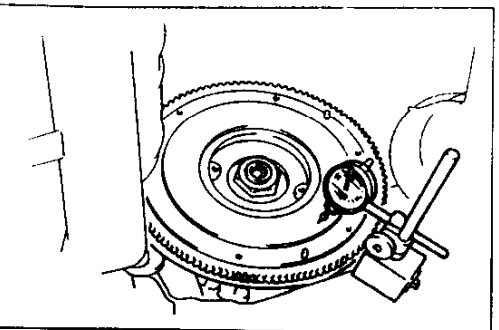

37U0HX-064

## CLUTCH RELEASE COLLAR

### INSPECTION

**Caution**

- Inspect for wear and damage, and replace if necessary.
- The clutch release collar is a sealed bearing and must not be washed in solvent or by steam cleaning.

1. Turn the collar while applying force in the axial direction. If the collar sticks or has excessive resistance, replace it.
2. Inspect for wear and damage to the release collar groove.

## PILOT BEARING

### INSPECTION

**Caution**

- Inspect for wear and damage, and replace if necessary.

**Note**

- Inspect the pilot bearing while it is installed in the flywheel.

Inspect the pilot bearing for wear or damage and check rotating condition.

## FLYWHEEL

### INSPECTION

**Caution**

- Inspect for wear and damage, and replace if necessary.

**Note**

- Remove minor scoring or burning with emery paper.

1. Inspect for scoring, cracks, and burning of the flywheel/clutch disc contact surface.
2. Inspect the ring gear teeth for wear and damage.
3. Measure the flywheel runout with a dial indicator. Replace the flywheel if runout is excessive.

**Runout: 0.2 mm {0.008 in} max.**

