

THIS MANUAL IS AN ONLINE BACKUP TO YOUR
ORIGINAL HARDCOPY VERSION.

RX7CITY.COM ASSUMES NO RESPONSIBILITY IN HOW YOU USE
THIS MANUAL. THIS MANUAL IS FOR EXPERIENCED MECHANICS
AND IS TO BE USED AT YOUR OWN RISK!



Before beginning any service procedure, refer to the 1993 RX-7 Body Electrical Troubleshooting Manual; see section S for air bag system precautions and J1 for audio anti-theft system precautions.

ENGINE ELECTRICAL SYSTEM

INDEX	G - 2
OUTLINE	G - 3
SPECIFICATIONS	G - 3
TROUBLESHOOTING GUIDE	G - 4
DIAGNOSTIC INDEX	G - 4
SYMPTOM TROUBLESHOOTING	G - 4
CHARGING SYSTEM	G - 7
PREPARATION	G - 7
CIRCUIT DIAGRAM	G - 7
TROUBLESHOOTING	G - 8
BATTERY	G - 9
ALTERNATOR	G -12
DRIVE BELT	G -15
IGNITION SYSTEM	G -16
PREPARATION	G -16
CIRCUIT DIAGRAM	G -16
IGNITION TIMING	G -17
SPARK PLUGS	G -18
IGNITION COIL	G -20
HIGH-TENSION LEAD	G -21
IGNITER	G -22
STARTING SYSTEM	G -24
PREPARATION	G -24
CIRCUIT DIAGRAM	G -24
STARTER	G -24
INTERLOCK SWITCH	G -32

INDEX

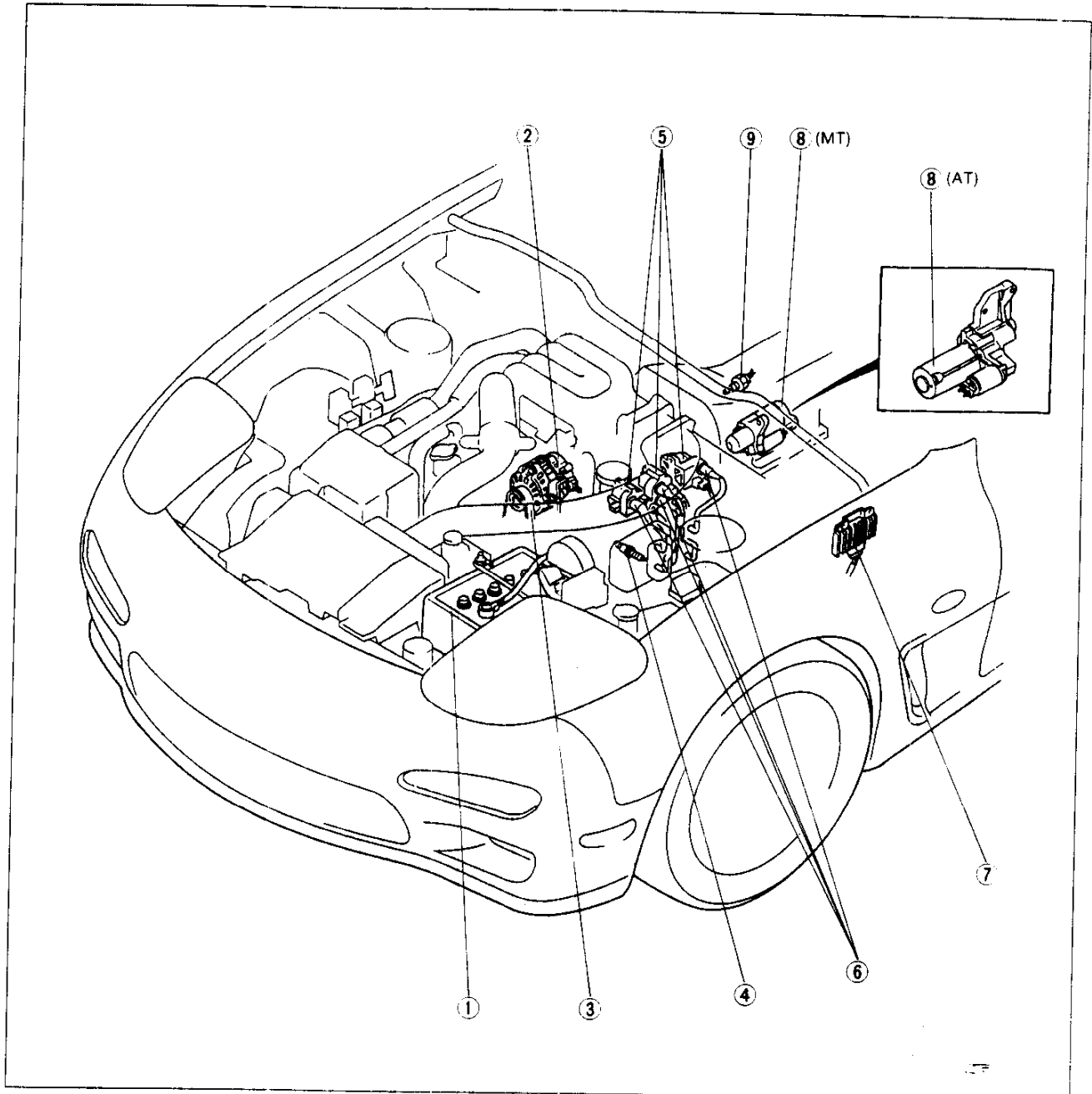

- 1. Battery
 - Removal / Installation page G- 9
 - Inspection page G- 9
 - Recharging page G-10
- 2. Alternator
 - Removal / Installation page G-12
 - Disassembly / Assembly page G-13
 - Inspection page G-14
- 3. Drive belt
 - Inspection page G-15
 - Adjustment page G-15

- 4. Spark plug
 - Removal / Installation page G-18
 - Spark test page G-18
 - Inspection page G-19
- 5. Ignition coil
 - Removal / Installation page G-20
 - Inspection page G-21
- 6 High-tension leads
 - Inspection page G-21
- 7. Igniter
 - Removal / Installation page G-22
 - Inspection page G-23

- 8. Stator
 - Inspection (On-Vehicle) page G-24
 - Removal / Installation page G-25
 - Performance inspection page G-27
 - Disassembly / Assembly page G-28
 - Inspection page G-30
- 9. Interlock switch
 - Inspection page G-32

37U0GX-01 2

OUTLINE

SPECIFICATIONS

Transmission		MT	AT	
Item				
voltage	V	12, negative ground		
Battery	Type and capacity (20-hour rate)	55D23L (60Ah) 65D23L (55Ah)* ¹	55D23L (60Ah) 75D26L (65Ah)* ¹	
Ignition system	Spark timing (test connector grounded)	Leading : ATDC 5° (BTDC - 5°) Trailing : ATDC 20° (BTDC - 20°) at idle (AT: P range)		
	Spark advance	Electronic spark advance (ESA)		
	Spark plug	Type	NGK : BUR7EQP* ² , BUR6EQP, BUR7EQ, BUR6EQ	
		Plug gap mm {in}	1.1-1.7 {0.044-0.066}	
Alternator	Output	V-A		
	Regulated voltage	V		
	Brush length	Standard mm {in}	21.5 {0.846}	
Minimum mm {in}		8.0 {0.315}		
Stator	Type	Direct	Reduction	
	Output	V-kW		
	Output (no load)	Voltage	V	
		Current	A	
		Speed	rpm	
	Brush length	Standard mm {in}	Min 3000	Min 2200
Minimum mm {in}		17.5 {0.689}	18 {0.71}	
		12 {0.47}	11 {0.43}	

*¹ Cold area
*² Standard plug

37U0GX-103

G

G

TROUBLESHOOTING GUIDE

TROUBLESHOOTING GUIDE





DIAGNOSTIC INDEX

No.	Troubleshooting Items	Page
1	Will not crank—starter motor does not operate	Below
2	Will not crank—starter motor spins	Below
3	Cranks slowly	G-5
4	Alternator warning lamp illuminates while engine running	G-5
5	Discharged battery	G-5
6	Misfire	G-6

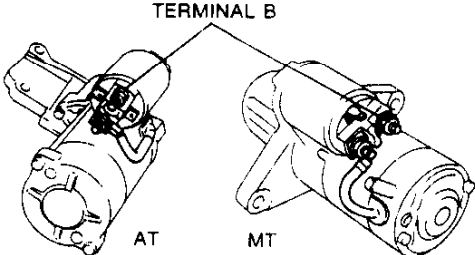
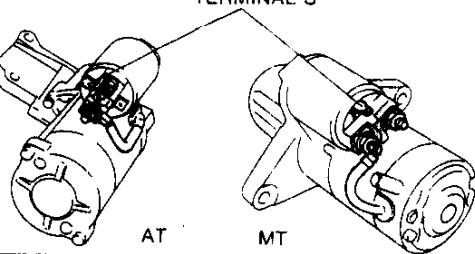

16E0C X-005

SYMPTOM TROUBLESHOOTING

V_B: Battery voltage

1		Will not crank—starter motor does not operate	
STEP	INSPECTION	ACTION	
1	Does engine crank with fully charged battery?	Yes	Check charging system  page G-8
		No	Go to next step
2	Is V _B present at terminal B? 	Yes	Go to next step
		No	Check wiring harness
3	Is V _B present at terminal S with ignition switch in START position? 	Yes	<ul style="list-style-type: none"> ● Check magnetic switch  page G-30 ● Check armature  page G-30
		No	<ul style="list-style-type: none"> ● Check inhibitor switch  Section K ● Check ignition switch  Section T ● Check wiring harness

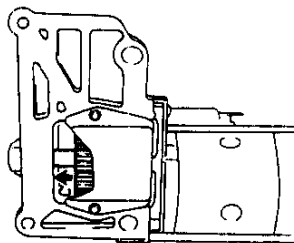
16E0GX-306

2		Will not crank—starter motor spins	
STEP	INSPECTION	ACTION	
1	Is drive pinion pushed out when energized? (Is click heard?) 	Yes	Remove starter and check ring gear teeth and starter drive pinion teeth
		No	Check magnetic switch  page G-30

16E0GX-C37

TROUBLESHOOTING GUIDE

G

3	Cranks slowly		
STEP	INSPECTION		ACTION
1	Does engine crank normally with fully charged battery?	Yes	Check charging system ☞ page G-8
		No	Go to next step
2	Are starter cable connections loose or corroded?	Yes	Repair connection
		No	Check starter for binding (brush, armature, etc.) ☞ page G-30

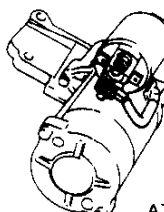
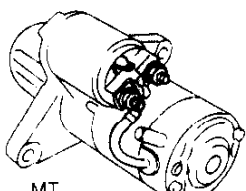



16E0G>-008

V_b: Battery Voltage

4	Alternator warning lamp illuminates while engine running		
STEP	INSPECTION		ACTION
1	Is V _b correct at idle? Specification: 14.1–14.7V	Yes	Check wiring harness (Alternator terminal L–Alternator warning lamp)
		No	Check charging system ☞ page G-8

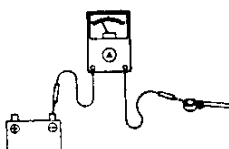
16E0G>-009

5	Discharged battery		
STEP	INSPECTION		ACTION
1	Is charging system OK? ☞ page G-8	Yes	Turn ignition switch ON and measure dark current as shown  Dark current: 20 mA max
		No	Repair or replace parts as necessary

16E0G>-010

G

TROUBLESHOOTING

TROUBLESHOOTING

V_b: Battery voltage

6		Misfire	
STEP	INSPECTION		ACTION
1	Are "02" or "03" displayed on SST while ignition switch ON?	Yes	Check for cause ☞ page F-20
		No	Go to next step
2	Are connector and wiring harness connections OK? (High-tension leads, igniter, ignition coils, ECU)	Yes	Go to next step
		No	Repair connection
3	Remove each high-tension lead; is there strong blue spark while engine is cranking?	Yes	Go to next step
		No	Replace
4	<ul style="list-style-type: none"> ● Are high-tension leads OK? ● Is resistance of high-tension leads OK? Specification: 16 kΩ per 1 m {3.28 ft} (at 20°C [68°F])	Yes	Go to next step
		No	Replace high-tension leads
5	Is there V _b at ignition coils terminal A and igniter terminal D with ignition switch in ON position? (Disconnect each connection)	Yes	Go to next step
		No	Check wiring harness (ignition coils terminal A and igniter terminal D-ignition switch)*
6	Are ignition coils OK? ☞ page G-21	Yes	Go to next step
		No	Replace ignition coil ☞ page G-20
7	Is wiring harness from ignition coils to igniter OK?*	Yes	Go to next step
		No	Repair or replace
8	Is ignitor OK? ☞ page G-23	Yes	Go to next step
		No	Replace igniter ☞ page G-22
9	Is wiring harness from ignitor to ECU terminals OK?*	Yes	Go to next step
		No	Repair or replace
0	Is input sensor OK? ● Crank angle sensor ☞ page F-180	Yes	Replace ECU ☞ page F-150
		No	Check input sensor

* Refer to circuit diagram

37U0GX-001

CHARGING SYSTEM

PREPARATION
SST

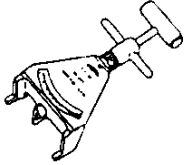
<p>49 9200 020 Tension gauge V-ribbed belt</p>		<p>For inspection of drive belt tension</p>
--	---	---

16E0GX-011

CIRCUIT DIAGRAM

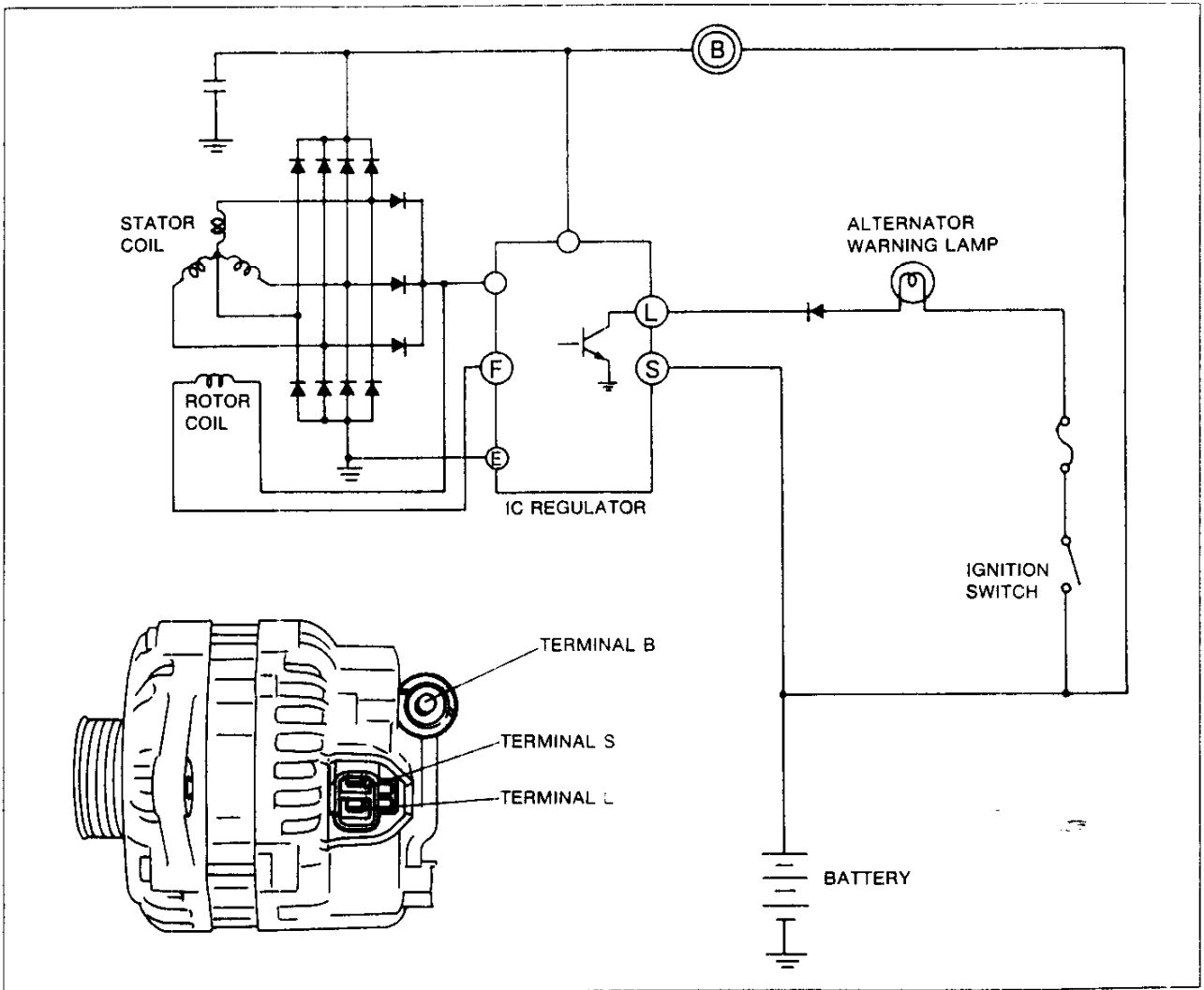

16E0GX 012

The alternator has a self-diagnosis function to warn of the following problems in the charging system. If a problem arises, the alternator warning lamp illuminates.

1. Terminal S circuit open
2. No voltage output
3. Field coil circuit open
4. Terminal B circuit open
5. Voltage output too high (above 16.2V)

G

CHARGING SYSTEM

TROUBLESHOOTING

V_B: Battery voltage

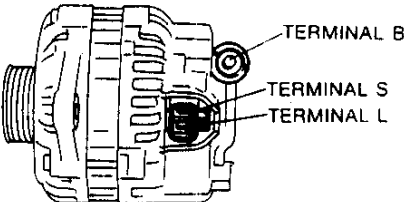
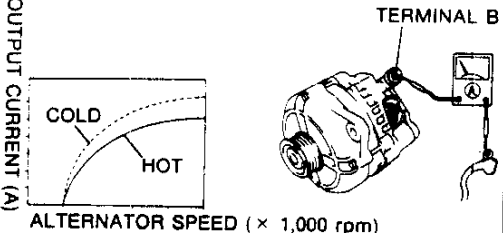
STEP	INSPECTION	ACTION													
1	Check battery voltage: is it correct? Specification: Above 12.4V	Yes	Go to next step												
		No	Check battery ☞ page G-9												
2	Does alternator warning lamp illuminate with ignition switch ON?	Yes	Go to Step 3												
		No	Check warning lamp bulb and wiring harness (Alternator warning lamp-Terminal L)												
3	Does alternator warning lamp go out after engine started?	Yes	Go to Step 5												
		No	Go to next step												
4	Is voltage at alternator terminals correct? Specification: <table border="1" style="margin: 10px auto;"> <thead> <tr> <th>Terminal</th> <th>Ign: ON (V)</th> <th>Idle (V)</th> </tr> </thead> <tbody> <tr> <td>B</td> <td>V_B</td> <td>14.1-14.7</td> </tr> <tr> <td>L</td> <td>Approx. 1</td> <td>12.9-13.5</td> </tr> <tr> <td>S</td> <td>V_B</td> <td>14.1-14.7</td> </tr> </tbody> </table> 	Terminal	Ign: ON (V)	Idle (V)	B	V _B	14.1-14.7	L	Approx. 1	12.9-13.5	S	V _B	14.1-14.7	Yes	Check wiring harness (Battery-Terminal B)
		Terminal	Ign: ON (V)	Idle (V)											
B	V _B	14.1-14.7													
L	Approx. 1	12.9-13.5													
S	V _B	14.1-14.7													
No	<ul style="list-style-type: none"> ● Check and repair wiring harness as necessary ☞ page G-12 ● Replace or repair alternator 														
5	1. Connect ammeter (100A min.) between terminal B and harness 2. Start engine 3. Turn all electrical loads ON and depress brake pedal 4. Is output current 100A or more at 2,500-3,000 rpm? Caution ● Do not ground terminal B	Yes	Charging system normal												
		No	Go to next step												
6	Is drive belt tension OK? ☞ page G-15 	Yes	Replace or repair alternator ☞ page G-12												
		No	<ul style="list-style-type: none"> ● Adjust drive belt tension ● Replace drive belt 												

16E0GX-01

BATTERY

Removal / Installation

1. Remove in the order shown in the figure.
2. Install in the reverse order of removal.

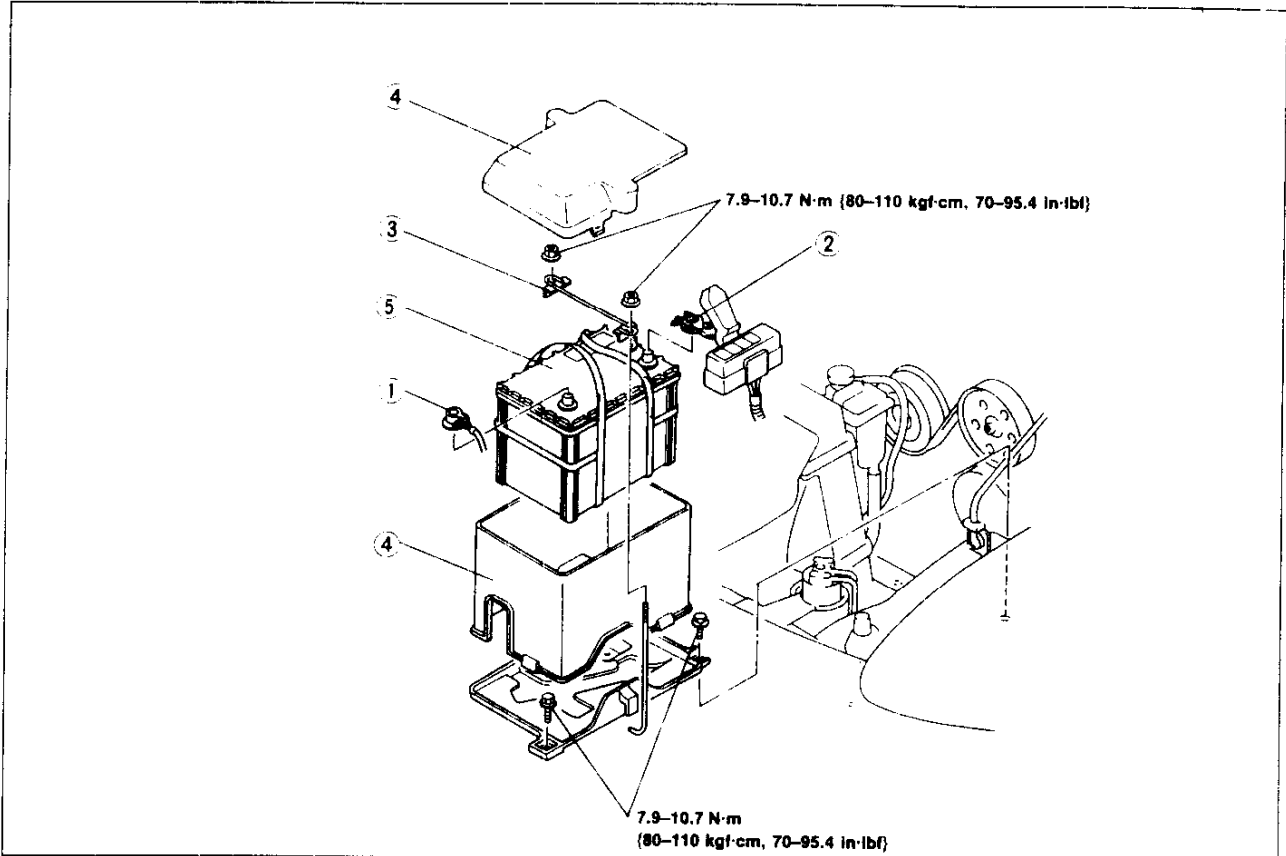

1. Battery negative cable
2. Battery positive cable

3. Battery clamp
4. Battery box

5. Battery

3/U0GX-015

Inspection page G- 9
 Recharging page G-10

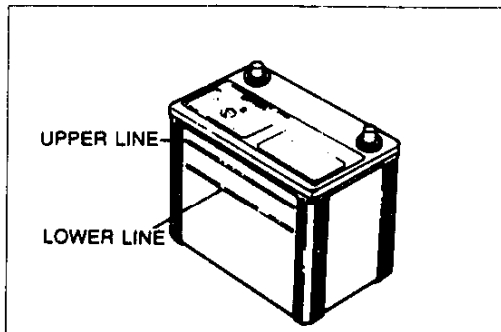

16E0GX-014

**Inspection
 Electrolyte level**

1. Check if the electrolyte level is between the upper and lower line.
2. If low, add distilled water, being careful not to overfill

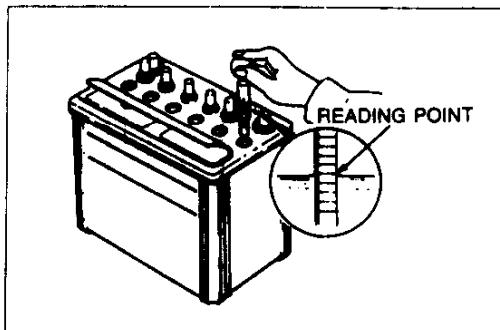

16E0GX-015

Specific gravity of electrolyte

Measure the specific gravity by using a hydrometer.

Specification: 1.27-1.29 (at 20°C {68°F})

Battery Discharge Test

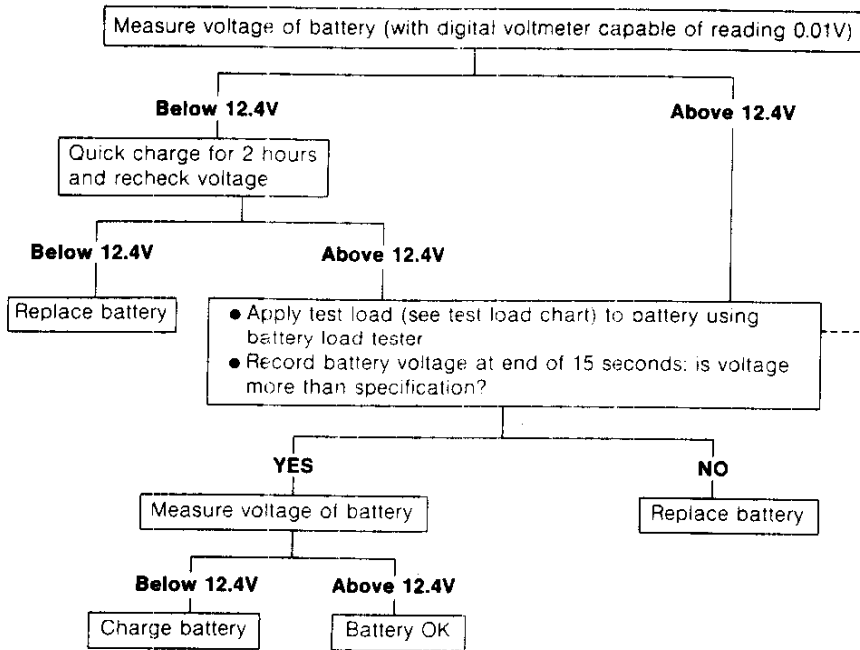

Test load

Battery	Load (A)
55D23L	180
65D23L	165
75D26L	195

Battery voltage with load

Approximate battery temp.	Minimum voltage (V)
21°C {70°F}	9.6
15°C {60°F}	9.5
10°C {50°F}	9.4
4°C {40°F}	9.3
-1°C {30°F}	9.1
-7°C {20°F}	8.9
-12°C {10°F}	8.7
-18°C { 0°F}	8.5

16E0GX-016

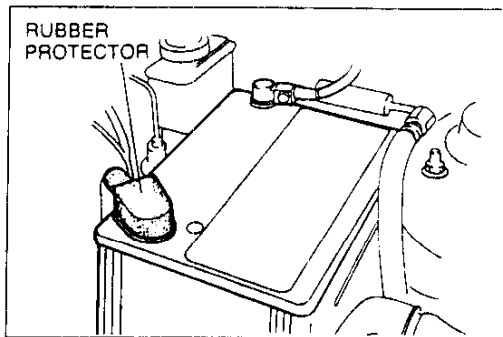

16E0GX-017

Terminal and cable

1. Check the tightness of the terminals to ensure good electrical connections.
2. Check for corroded and frayed battery cables. Replace if necessary.
3. Check the rubber protector on the positive terminal for proper coverage.
4. Clean the terminals if necessary, and coat them with grease.

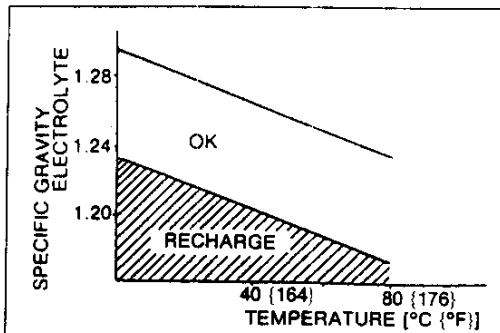

16E0GX-018

Recharging

Battery	Slow charge (A)	Quick charge (A)
55D23L	Under 6	Max. 30
65D23L	Under 5	Max. 25
75D26L	Under 8	Max. 30

Slow charging

If is not necessary to remove the vent caps to perform a slow charge.

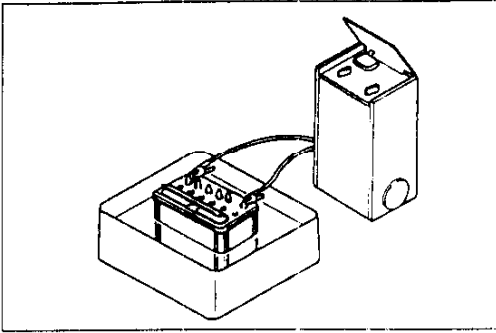

16E0GX 01-3

Quick charging

Remove the battery from the vehicle and remove the vent caps to perform a quick charge.

Caution

- Obtain the code number and deactivate the audio anti-theft system before disconnecting the battery. (Refer to T section)

Warning

- Before performing maintenance or recharging the battery, turn OFF all accessories and stop the engine.
- The negative cable must be removed first and installed last.
- Set the battery in water when quick charging to prevent overheating the battery.

ALTERNATOR

Caution

- Be sure the battery connections are not reversed as this will damage the rectifier.
- Do not use high-voltage testers such as a megger as they will damage the rectifier.
- Remember that battery voltage is always present at alternator terminal B.
- Do not ground terminal L while the engine is running.
- Do not start the engine while the connector is disconnected from terminals L and S.

Removal / Installation

1. Remove in the order shown in the figure.
2. Install in the reverse order of removal.

37U0GX 006

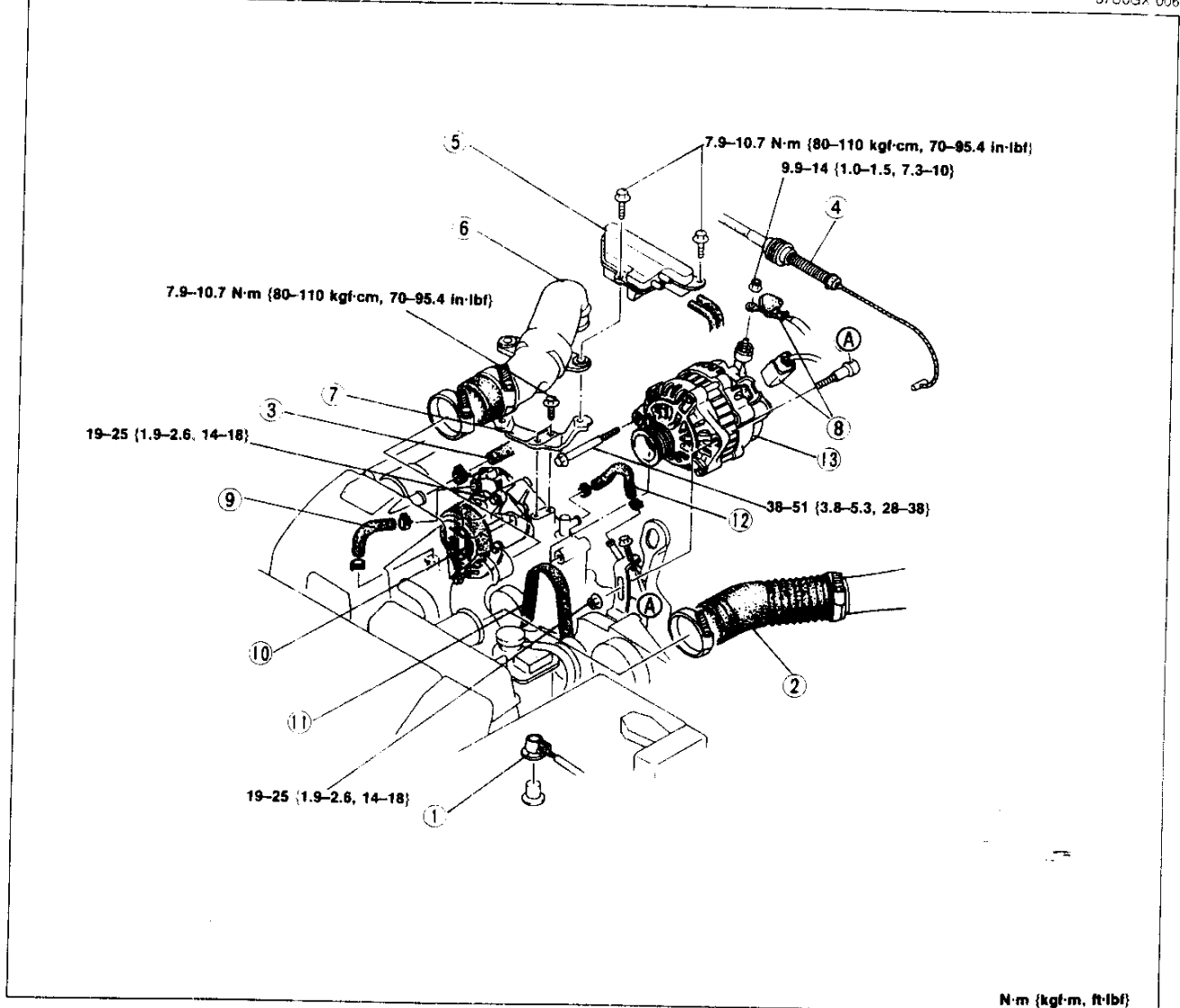

N-m (kgf-m, ft-lbf)

37U0GX-007

1. Battery (negative cable)
Removal / Installation
..... page G- 9
2. Air-intake hose
3. Air-relief hose
4. Accele cable
5. Pressure chamber
6. Air pipe

7. Bracket
8. Terminal B and connector
9. Air pump hose
10. Air pump
11. Drive belt
Inspection page G-15
Adjustment ... page G-15

12. Water hose
13. Alternator
Disassembly / Assembly
..... page G-13
Inspection page G-14

Disassembly / Assembly

1. Disassemble in the order shown in the figure, referring to **Disassembly Note**.
2. Inspect all parts and repair or replace as necessary.
3. Assembly in the reverse order of disassembly, referring to **Assembly Note**.

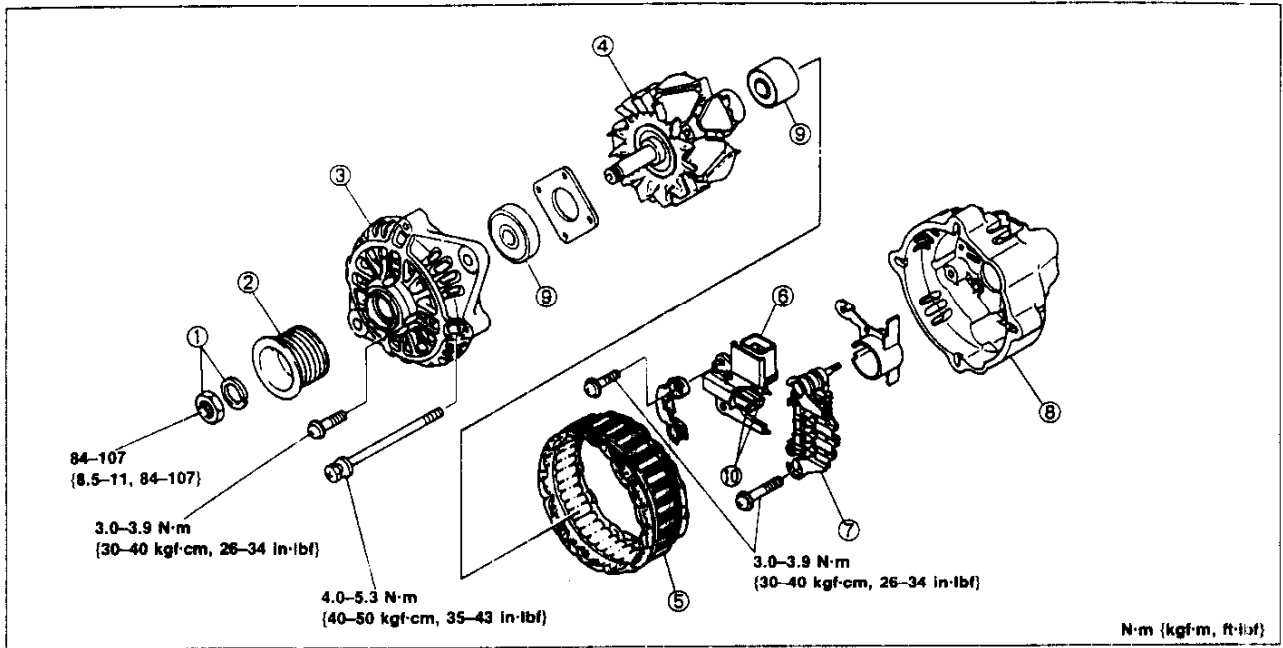

37U0GX 008

- | | | |
|----------------------------|----------------------------|----------------------------|
| 1. Nut, washer | 6. Regulator | 8. Rear bracket |
| 2. Pulley | Disassembly / Assembly | Disassembly / Assembly |
| 3. Front bracket | Note page G-13 | Note..... page G-13 |
| 4. Rotor | 7. Rectifier | 9. Bearing |
| Inspection page G-14 | Disassembly / Assembly | Inspection page G-14 |
| 5. Stator | Note page G-13 | 10. Brush |
| Disassembly / Assembly | Inspection page G-14 | Inspection page G-14 |
| Note page G-13 | | |
| Inspection page G-14 | | |

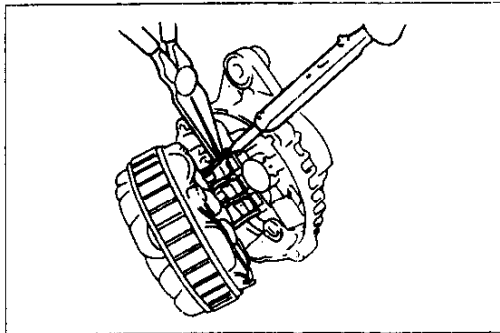

37U0GX-009

Disassembly / Assembly Note

Rear bracket, stator wire

Melt the solder quickly, the diodes (rectifier) and regulator will be damaged by excessive heat.

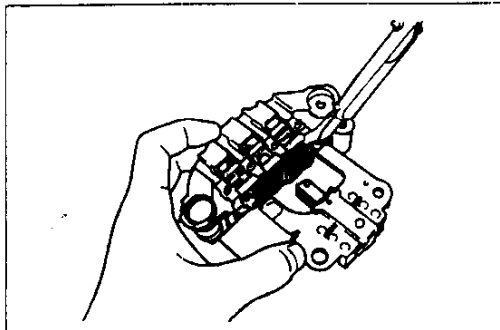

37U0GX-010

Brush holder, regulator assembly and rectifier

Melt the solder quickly, the diodes (rectifier) and regulator will be damaged by excessive heat.

G

CHARGING SYSTEM

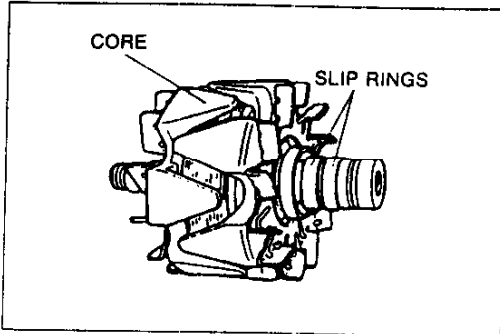

37U0GX-011

Inspection Rotor

- Check the continuity as shown.

Inspection point	Continuity
Core - Slip ring	No
Slip ring - Slip ring	Yes

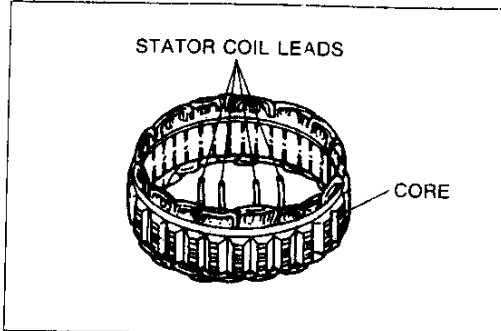

37U0GX-012

Stator

- Check the continuity as shown.

Inspection point	Continuity
Core - Stator coil leads	No
Between leads	Yes

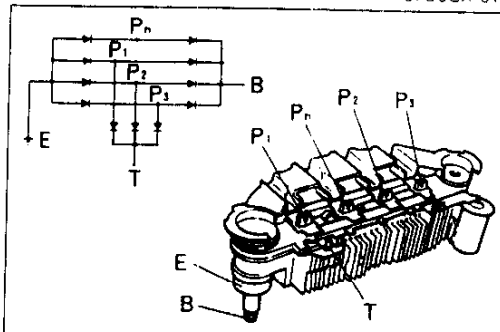

37U0GX-013

Rectifier

- Check the continuity as shown.

Negative	Positive	Continuity
E	P _n , P ₁ , P ₂ , P ₃	Yes
B		No
T		No
P _n , P ₁ , P ₂ , P ₃	E	No
	B	Yes
P ₁ , P ₂ , P ₃	T	Yes
		No

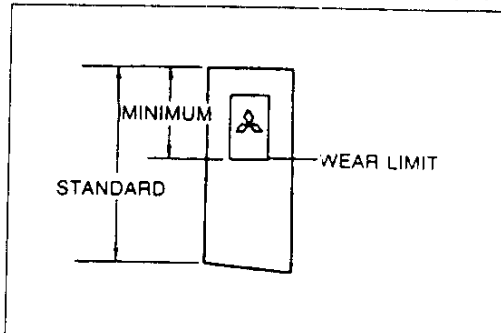

37U0GX-014

Brush

If a brush is worn almost to or beyond the limit, replace the brushes.

Standard: 21.5 mm {0.847 in}

Minimum: 8 mm {0.31 in}

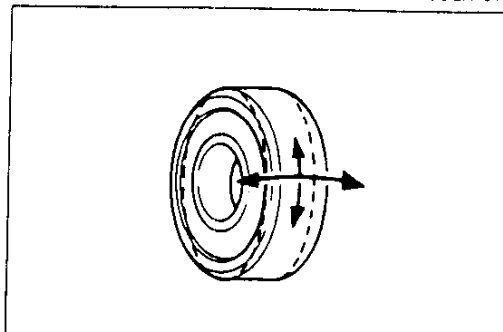

37U0GX-015

Bearing

1. Check for abnormal noise, looseness, and sticking.
2. Replace the bearing(s) as necessary.

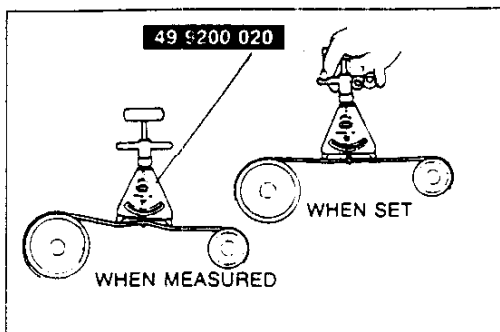

93E0GX-031

DRIVE BELT

Inspection

1. Check the drive belts and pulleys for wear, cracks and fraying. Replace as necessary.
2. Measure the drive belt tension by using a tension gauge, and measure the deflection by applying moderate pressure midway between the pulleys. Adjust the belt if necessary.

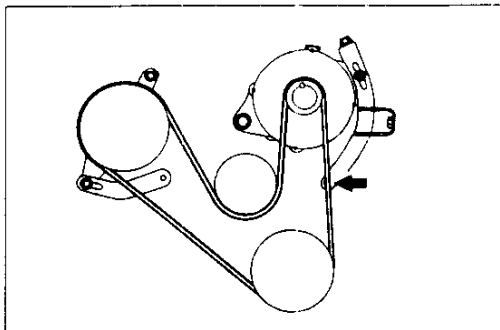

37U0GX-016

Tension

Tension: N {kgf, lbf}

New : 687-784 {70-80, 154-176}

Used: 589-686 {60-70, 132-154}

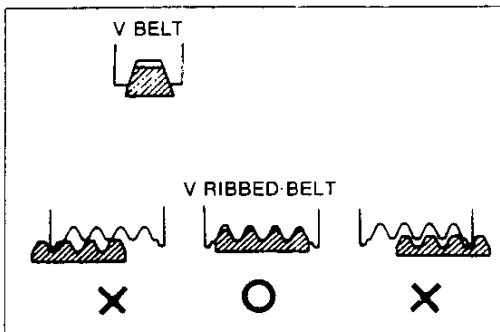

37U0GX-017

Deflection

Deflection: mm {in} / 98 N {10 kgf, 22 lbf}

New : 6-8 {0.24-0.31}

Used: 7-9 {0.28-0.35}

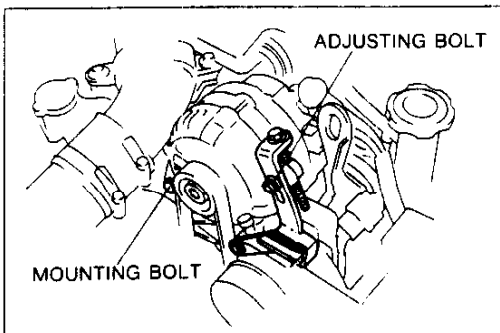

93E0GX-034

Adjustment

1. Loosen the alternator mounting bolts and turn the adjusting bolt.
2. Move the alternator to set the specified deflection.
3. Tighten all bolts and recheck the tension.

Tightening torque:

Mounting bolt:

38-51 N·m {3.8-5.3 kgf·m, 28-38 ft·lbf}

Adjusting bolt:

19-25 N·m {1.9-2.6 kgf·m, 14-18 ft·lbf}

G

IGNITION SYSTEM

IGNITION SYSTEM

PREPARATION

SST

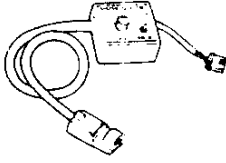
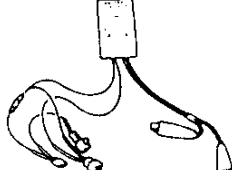
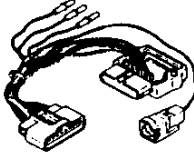
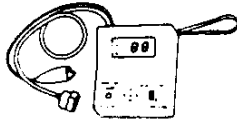
<p>49 B019 9A0</p> <p>System selector</p> 	<p>For self-diagnosis and inspection of ignition timing</p>	<p>49 F018 002</p> <p>Igniter Checker</p> 	<p>For inspection of igniter</p>
<p>49 F018 003</p> <p>Adapter Harness</p> 	<p>For inspection of igniter</p>	<p>49 H018 9A1</p> <p>Self-Diagnosis Checker</p> 	<p>For self-diagnosis inspection</p>

CIRCUIT DIAGRAM

37U0GX-C18

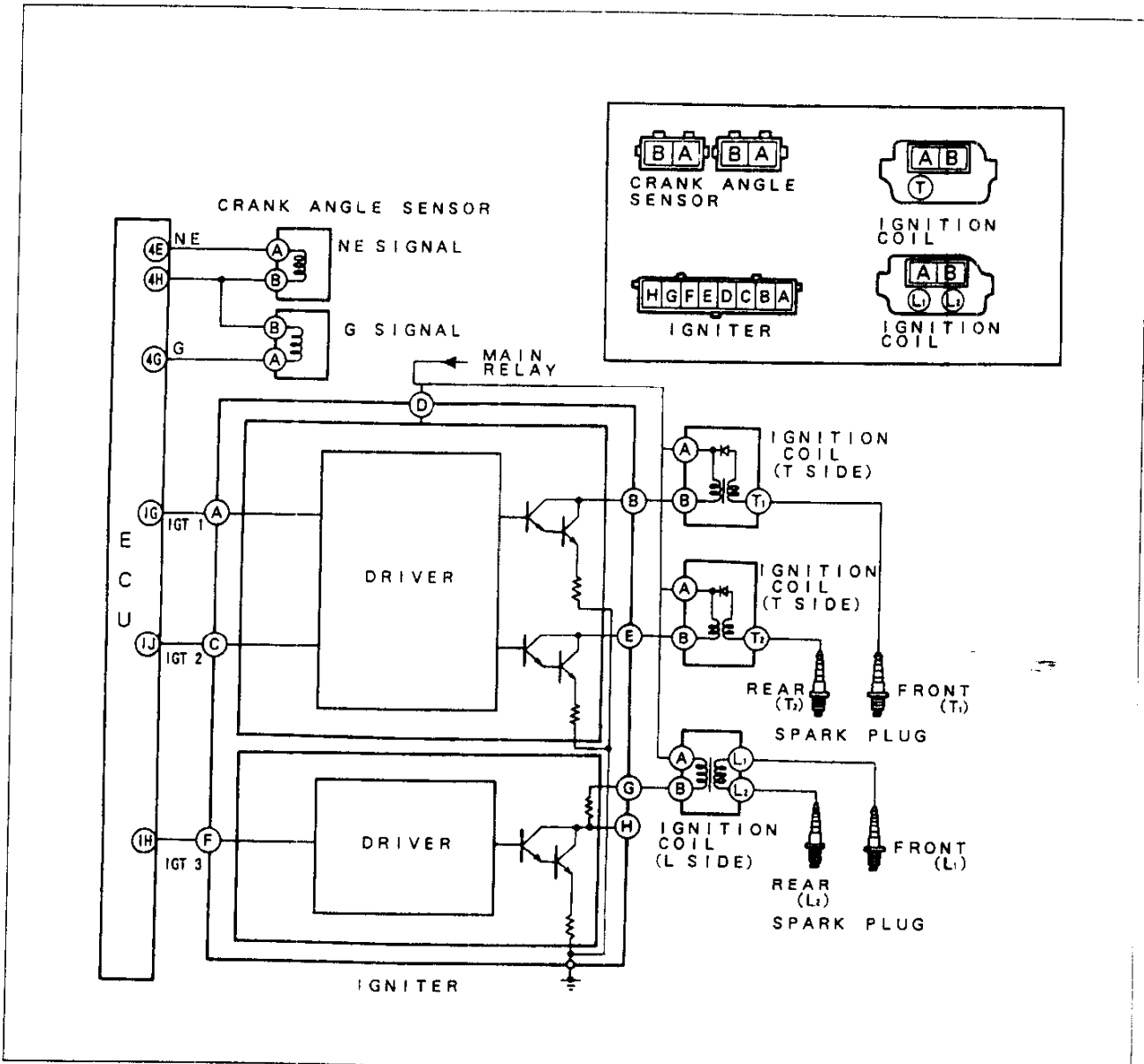

37U0GX-019

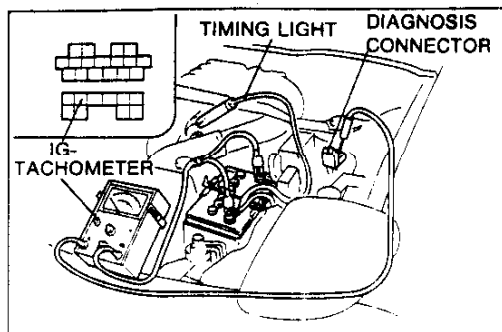

37U0GX-020

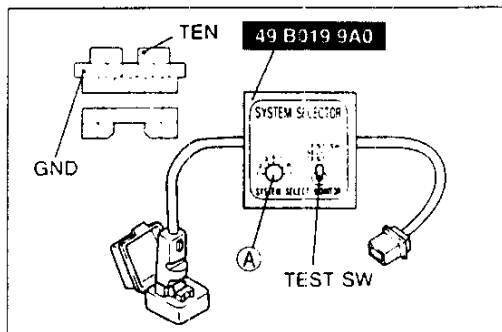

37U0GX-021

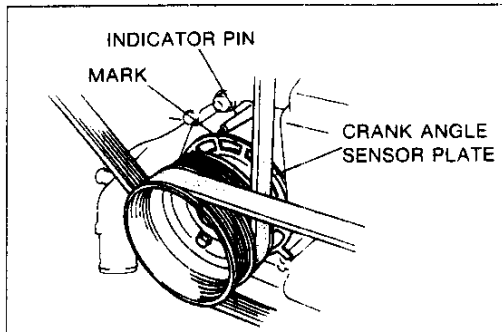

37U0GX-022

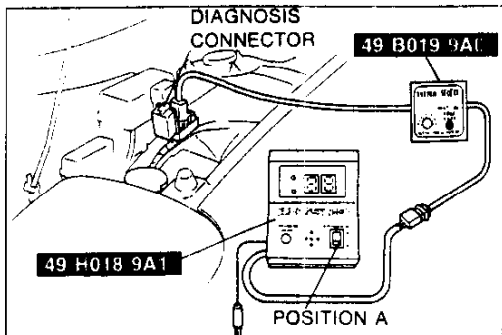

37U0GX-023

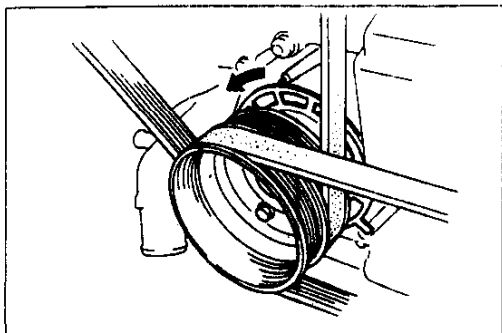

37U0GX-024

IGNITION TIMING

Caution

- Do not adjust the ignition timing, it is set at the factory and must not be tempered with.

Preparation

1. Warm up the engine to normal operating temperature.
2. Run the engine at idle and verify the following.
 - Shift selector lever to Prange (AT) / Neutral (MT).
 - Set steering wheel straight ahead.
 - Turn all electrical loads OFF.
 - Wait for electric cooling fan to stop.

Inspection

1. Connect a timing light and a tachometer.

Caution

- Connect the timing light to the high-tension lead of the front trailing side.
- Some timing lights will not illuminate even if the ignition system is normal.

2. Connect the **SST** to the diagnosis connector.
3. Set switch A to position 1.
4. Set TEST SW to SELF-TEST.
5. Verify that the idle speed is within specification.

Idle speed: 550–950 rpm

6. Verify that the timing mark (white) on the crank angle sensor plate is aligned with the indicator pin.

Ignition timing: Trailing side: 20°ATDC (– 20°BTDC) Leading side: 5°ATDC (– 5°BTDC)

7. If the timing is incorrect, check the following.
 - Verify that no service code number is present. If present, check for the cause referring to the specified check sequence. (Refer to page F-20)
 - 05 Knock sensor
 - 13 Pressure sensor

Input devices

- E/L, P/S, A/C, electric cooling fan
- Crank angle sensor (NE,G-Signal)
- Pressure sensor
- Throttle sensor
- Neutral SW / Clutch SW (MT)
- Inhibitor signal (AT)

Others

- ECU terminal 3I voltage

8. Disconnect the **SST**.
9. Verify that the ignition timing advances when the engine is above 1,500 rpm.

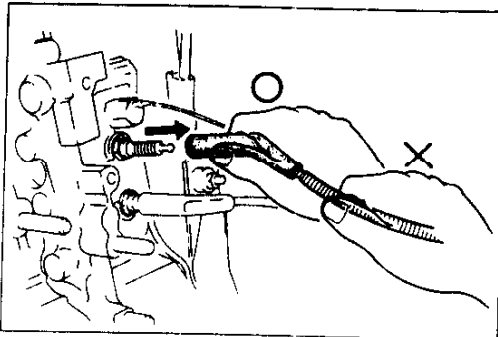

37U0GX-025

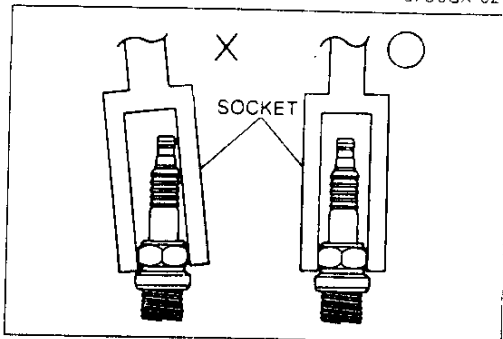

37U0GX-026

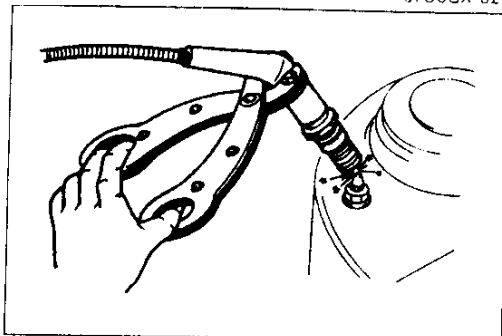

37U0GX-027

SPARK PLUGS**Removal / Installation**

1. Remove and install the high-tension leads carefully

Caution

- When the spark plug lead is to be pulled off, be sure to pull on the boot itself, not the wire.

2. Remove and install the spark plugs by using a plug socket.

Caution

- Be sure the socket is fit squarely over the spark plug.

3. Apply anti-seize compound or molybdenum-based lubricant to the spark plug threads before installing.
4. Tighten the spark plugs to the specified torque.

Tightening torque:

13–17 N·m {1.3–1.8 kgf-m, 9.5–13 ft-lbf}

Spark test

1. Remove the spark plug.
2. Connect the spark plug to a high-tension lead.
3. Hold the high-tension lead and spark plug with insulated pliers 5–10 mm {0.20–0.39 in} from a ground.
4. Check the engine and verify that there is a strong blue spark.

Note

- If not as specified, replace the spark plug or high-tension lead as necessary.

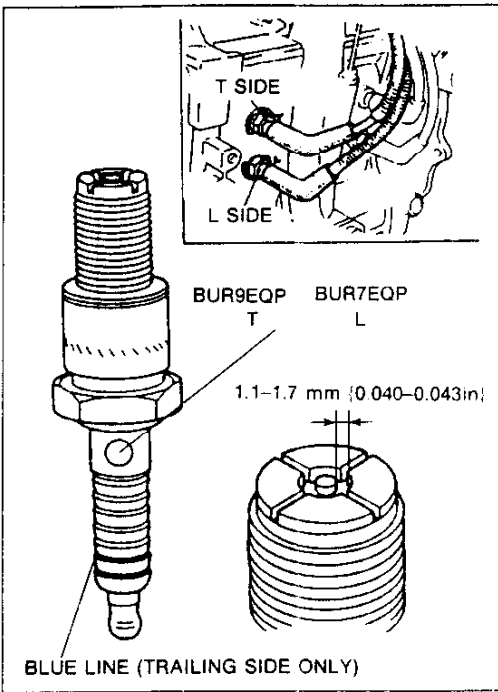

Inspection

Check the following points. If a problem is found, replace the spark plug.

- Damaged insulation
- Worn electrodes
- Carbon deposits

If cleaning is necessary, use a plug cleaner or a wire brush. Clean the upper insulator, also.

- Damaged gasket
- Burnt

Plug gap: 1.1–1.7 mm {0.044–0.066 in}

Plug position	NGK	Color
Leading side	BUR7EQP*, (BUR7EQ) (BUR6EQP) (BUR6EQ)	—
Trailing side	BUR9EQP*, (BUR9EQ) (BUR8EQP) (BUR8EQ)	Blue

* Standard plug

Caution

- **To protect the platinum electrode:**
 - (1) Do not use a wire brush to clean the electrode.
 - (2) Use a plug cleaner for a maximum of 20 seconds and air pressure below 589 kPa {6 kg/cm², 85 psi}.
 - (3) Do not adjust the plug gap to protect a platinum electrode.

G

IGNITION SYSTEM

IGNITION COIL

Removal / Installation

1. Remove in the order shown in the figure.
2. Install in the reverse order of removal.

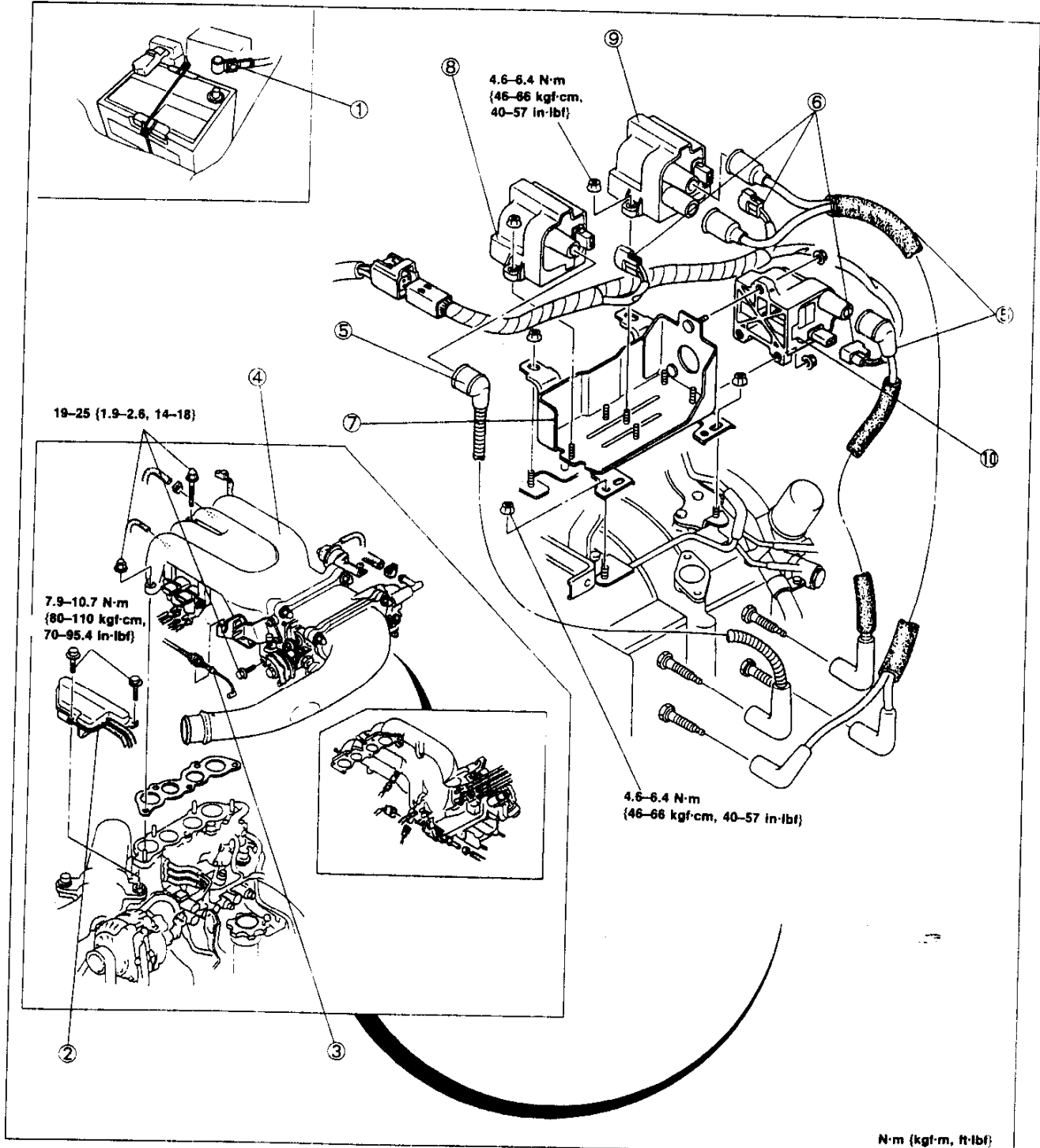

1. Battery negative cable
2. Pressure chamber
3. Accelerator cable
4. Extension manifold

5. High-tension lead
Inspection page G-21
6. Connector
7. Ignition coil bracket
8. Ignition coil (Trailing No.1)
Inspection page G-21

9. Ignition coil (Leading)
Inspection page G-21
10. Ignition coil (Trailing No.2)
Inspection page G-21

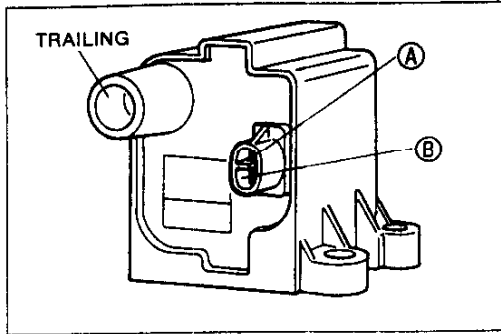

37U0GX-030

Inspection
T (Trailing) side

1. Measure resistance of the coil.

Inspection point	Resistance
A-B (primary coil winding)	below 1.0 Ω
A-T (secondary coil winding)	∞ (infinity)

2. If not within specification, replace the ignition coil.

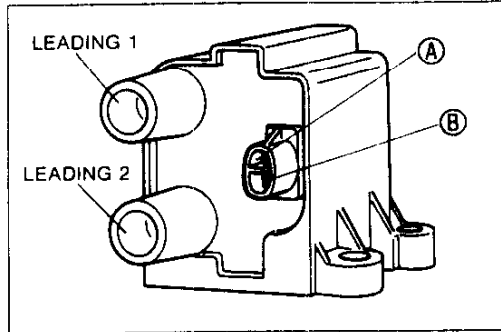

37U0GX-031

L (Leading) side

1. Measure resistance of the coil.

Inspection point	Resistance
A-B (primary coil winding)	below 1.0 Ω
L ₁ -L ₂ (secondary coil winding)	9.6-16.0 k Ω

2. If not within specification, replace the ignition coil.

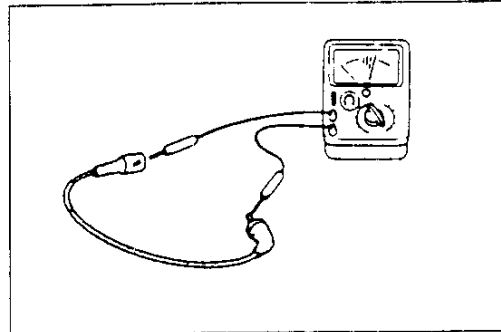

37U0GX-032

HIGH-TENSION LEAD

Inspection

1. Measure resistance of the high-tension leads.

Specification: 16 k Ω per 1 m {3.28 ft}

2. If not as specified, replace the high-tension leads.

G

IGNITION SYSTEM

IGNITER

Removal / Installation

1. Remove in the order shown in the figure.
2. Install in the reverse order of removal.

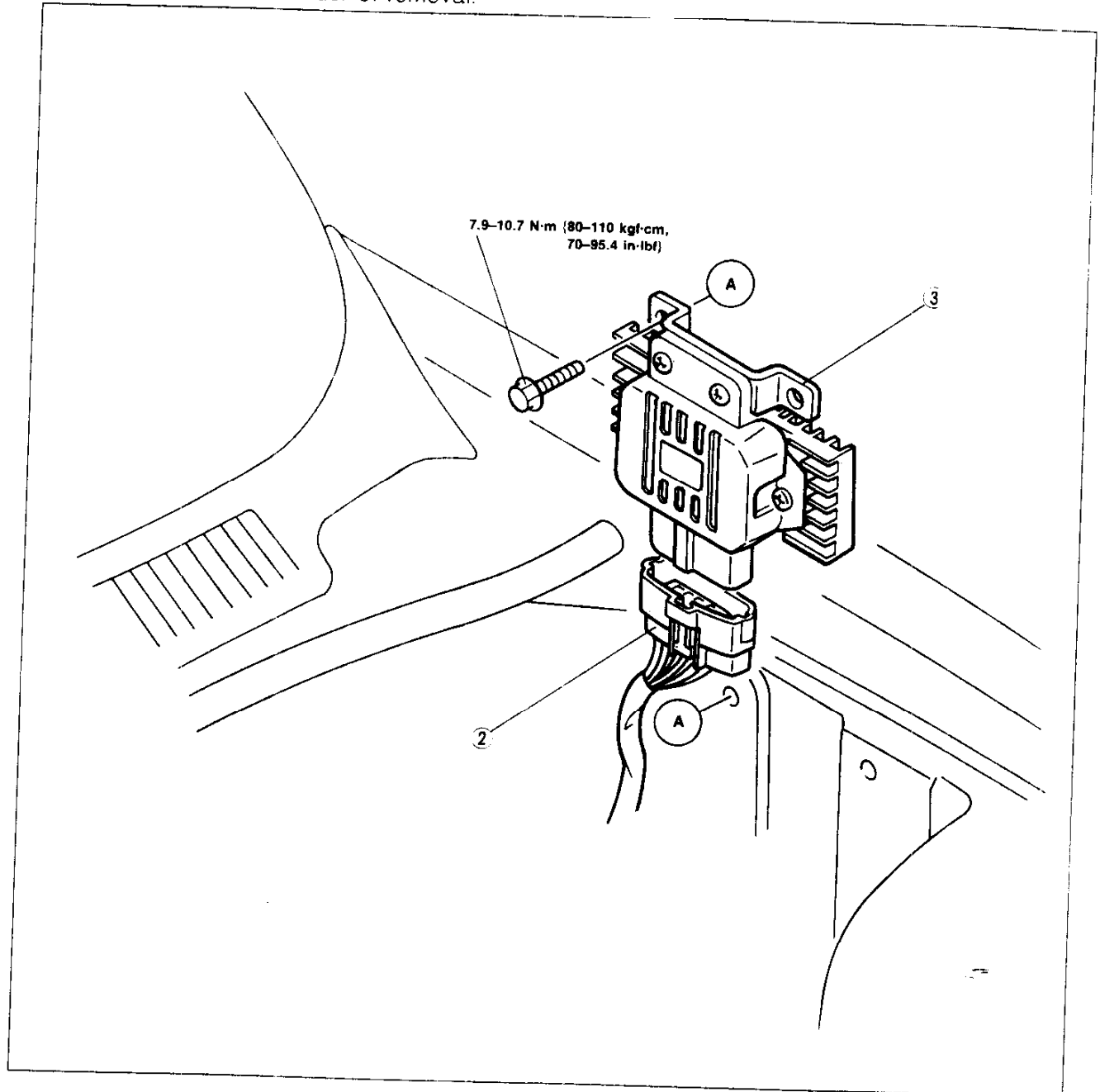

1. Battery negative cable
2. Connector

3. Igniter
- Inspection page G-23

37U0GX-03

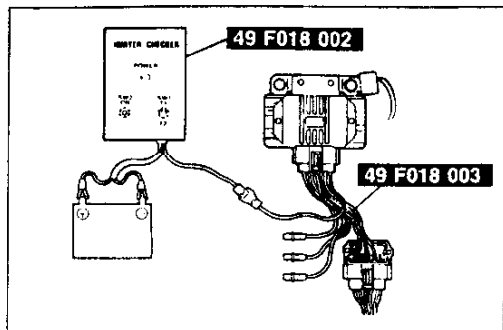

37U0GX-034

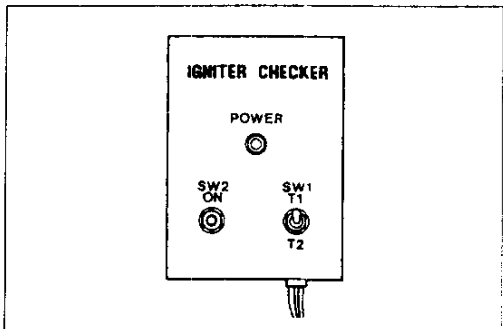

37U0GX-035

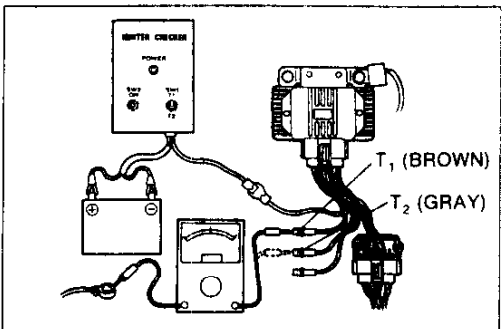

37U0GX-036

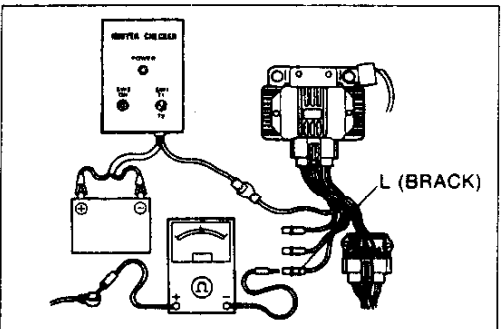

37U0GX-037

Inspection

Before this inspection, check the specific gravity of the battery, and that it is at or near full charge.

Note

● **SST (Adapter harness, Igniter checker) are used for inspection of the igniter.**

1. Disconnect the negative battery cable.
2. Disconnect the igniter connector.
3. Connect the **SST**.
4. Reconnect the negative battery cable.
5. Turn the ON ignition switch.

Note

● **Switch 1 may be in any position.**

Trailing side

1. Insert the voltmeter probe into the brown (Front rotor trailing) or gray (Rear rotor trailing) lead of the **SST** (adapter harness) and verify that the voltage is as specified.

Voltage: Battery voltage

2. Press switch 2 to ON when certify to shake a hand of voltmeter.
3. Replace the igniter, if necessary.

Leading side

1. Insert the voltmeter probe into the black lead of the **SST** (adapter harness) and verify that the voltage is as specified.

Voltage: Battery voltage

2. Press switch 2 to ON when certify to shake a hand of voltmeter.
3. Replace the igniter, if necessary.

G

STARTING SYSTEM

STARTING SYSTEM

PREPARATION

SST

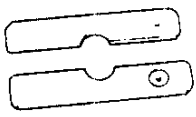
49 E301 144		For installation of overrunning clutch
Plate, removing		

16E0GX-071

CIRCUIT DIAGRAM

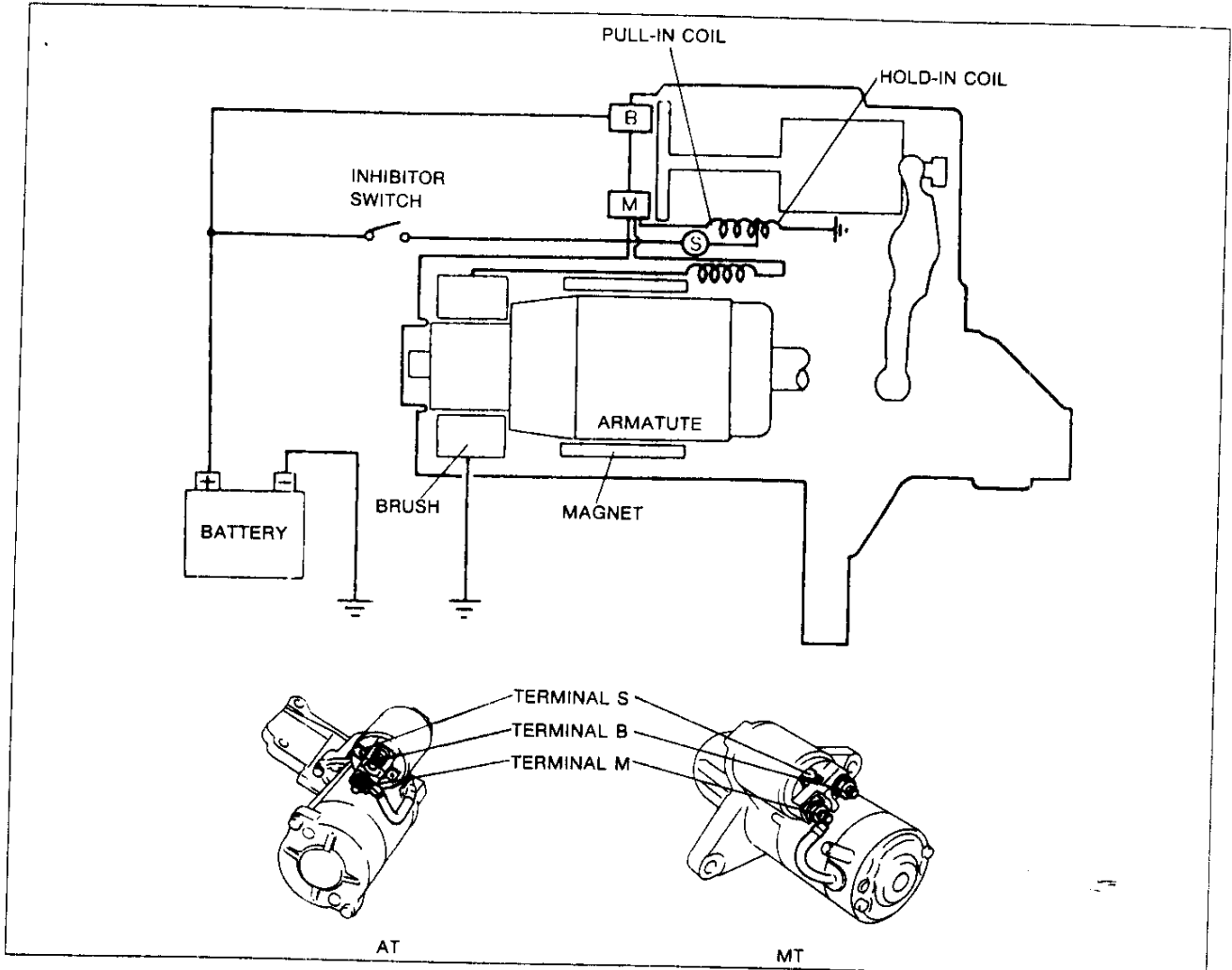

37U0GX-039

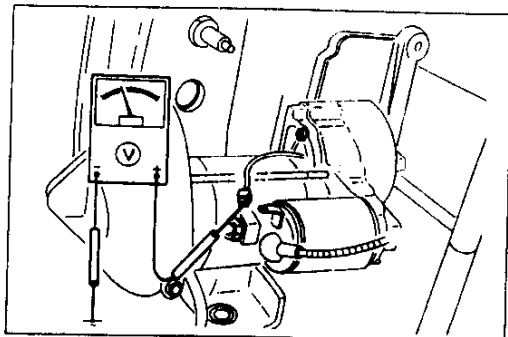

16E0GX-073

STARTER

Inspection (on-vehicle)

1. Measure the battery voltage.

Specification: Above 12.4V

2. Crank the engine, and verify that the starter turns smoothly.

3. If the starter does not turn, measure the voltage at terminal S.

4. If the voltage is **more than 8V**, remove and inspect the starter. If the voltage is **less than 8V**, check the wiring harness, ignition switch, and inhibitor switch (AT).

Removal / Installation

1. Remove in the order shown in the figure.
2. Inspect all parts and repair or replace as necessary.
3. Install in the reverse order of removal.

MT

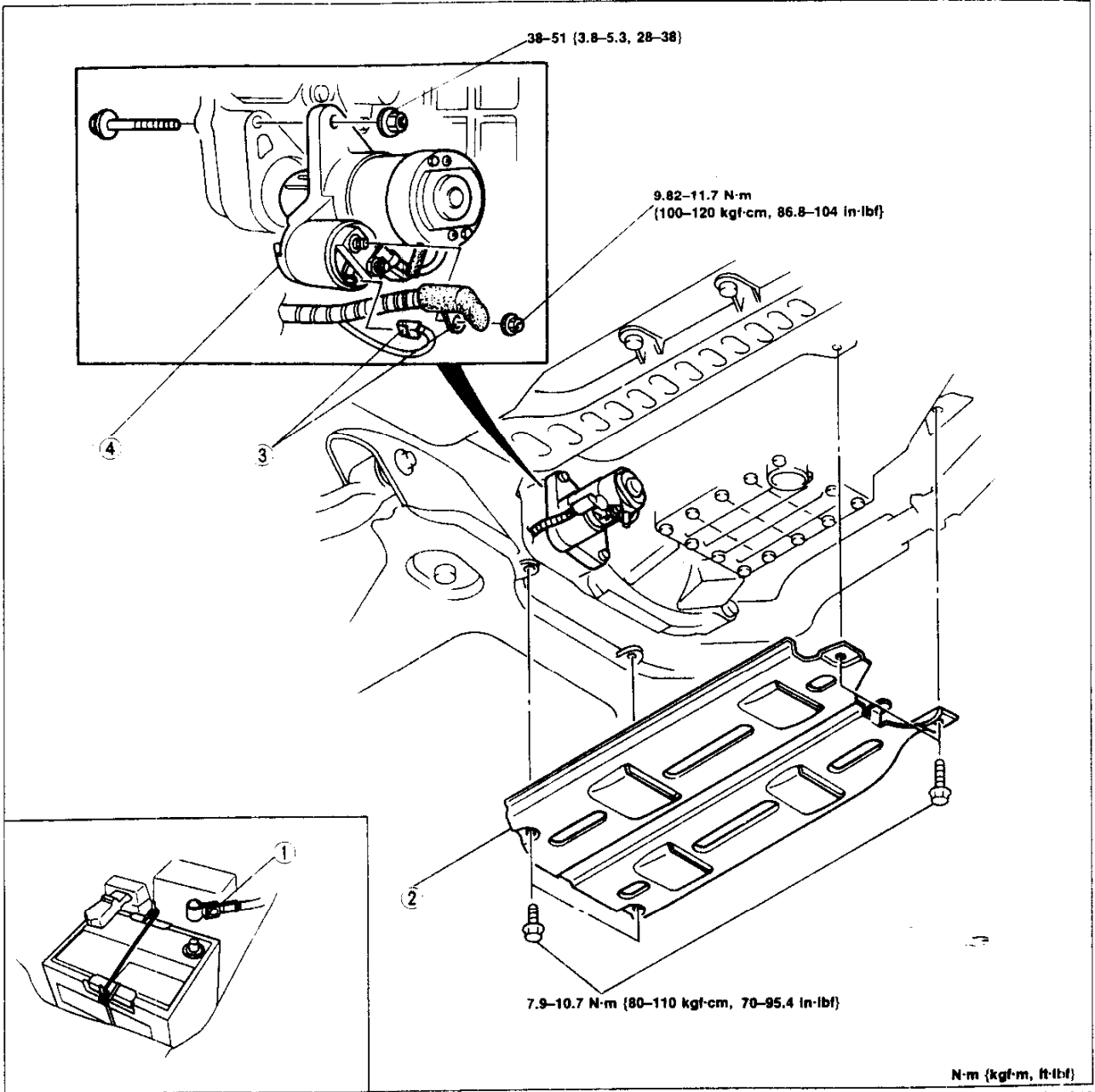

N·m (kgf·m, ft·lbf)

37U0GX-040

1. Battery negative cable
2. Under cover
3. Terminal S and B wire

4. Stator
 - Performance inspection page G-27
 - Disassembly / Assembly page G-28
 - Inspection page G-30

G

STARTING SYSTEM

AT

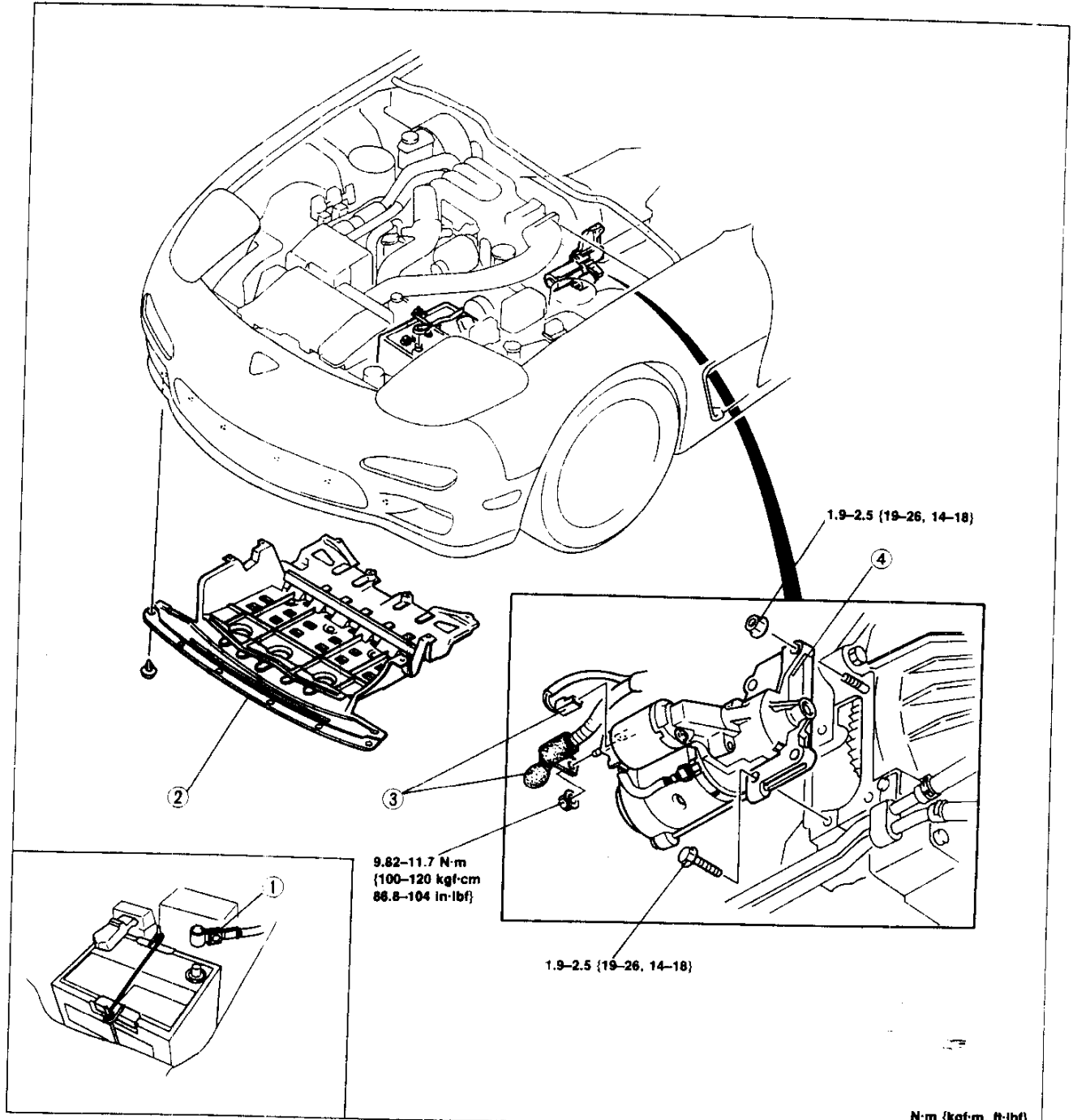

1. Battery negative cable
2. Under cover
3. Terminal S and B wire

4. Stator
- Performance inspection page G-27
Disassembly / Assembly page G-29
Inspection page G-30

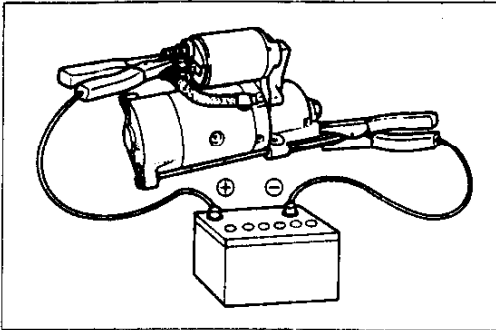

37U0GX-042

Performance Inspection

Magnetic switch

Disconnect terminal M wire, and perform the following tests. Replace the magnetic switch if necessary.

Pull-in test

Connect battery voltage as shown and verify that the pinion is ejected.

Caution

- Do not apply power for more than 10 seconds.

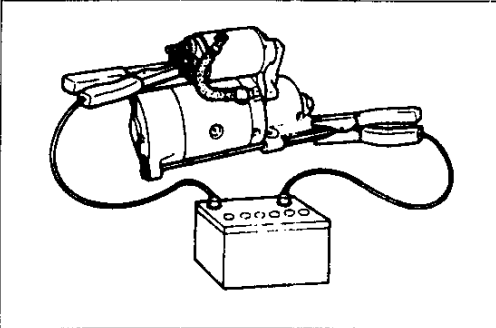

16E0GX-078

Hold-in test

After completing the pull-in test, disconnect the wire from terminal M (with pinion ejected) and verify that the pinion does not return.

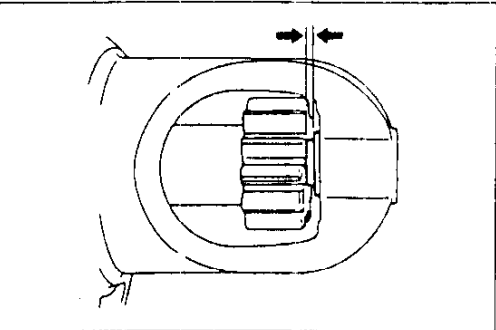

16E0GX-079

Adjustment of pinion gap

1. Disconnect the wire from terminal M.
2. Apply battery voltage between terminal S and the starter body.
3. Measure the clearance (pinion gap) between the pinion and the stopper.

Note

- Do not apply power for more than 10 seconds.

Pinion gap: 0.5–2.0 mm {0.020–0.078 in}

4. If the pinion gap is not within specification, increase or decrease the number of washers between the magnetic switch and the drive housing.

Note

- The gap becomes smaller as the number of washers is increased.

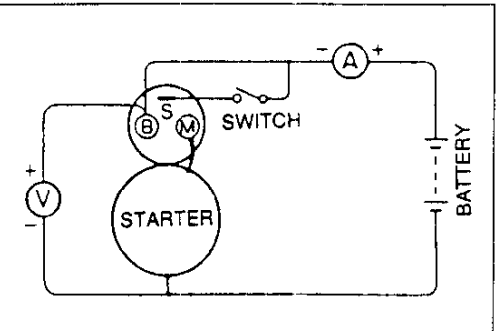

16E0GX-080

No load test

1. Connect a circuit as shown.
2. Measure voltage, current, and speed as shown below.

Voltage (V)	11.0
Current (A)	Max 90
Speed (rpm)	Min 2,200 (AT), Min 3,000 (MT)

G

STARTING SYSTEM

Disassembly / Assembly

1. Disassemble in the order shown in the figure.
2. Inspect all parts and repair or replace as necessary.
3. Assemble in the reverse order of disassembly.

MT

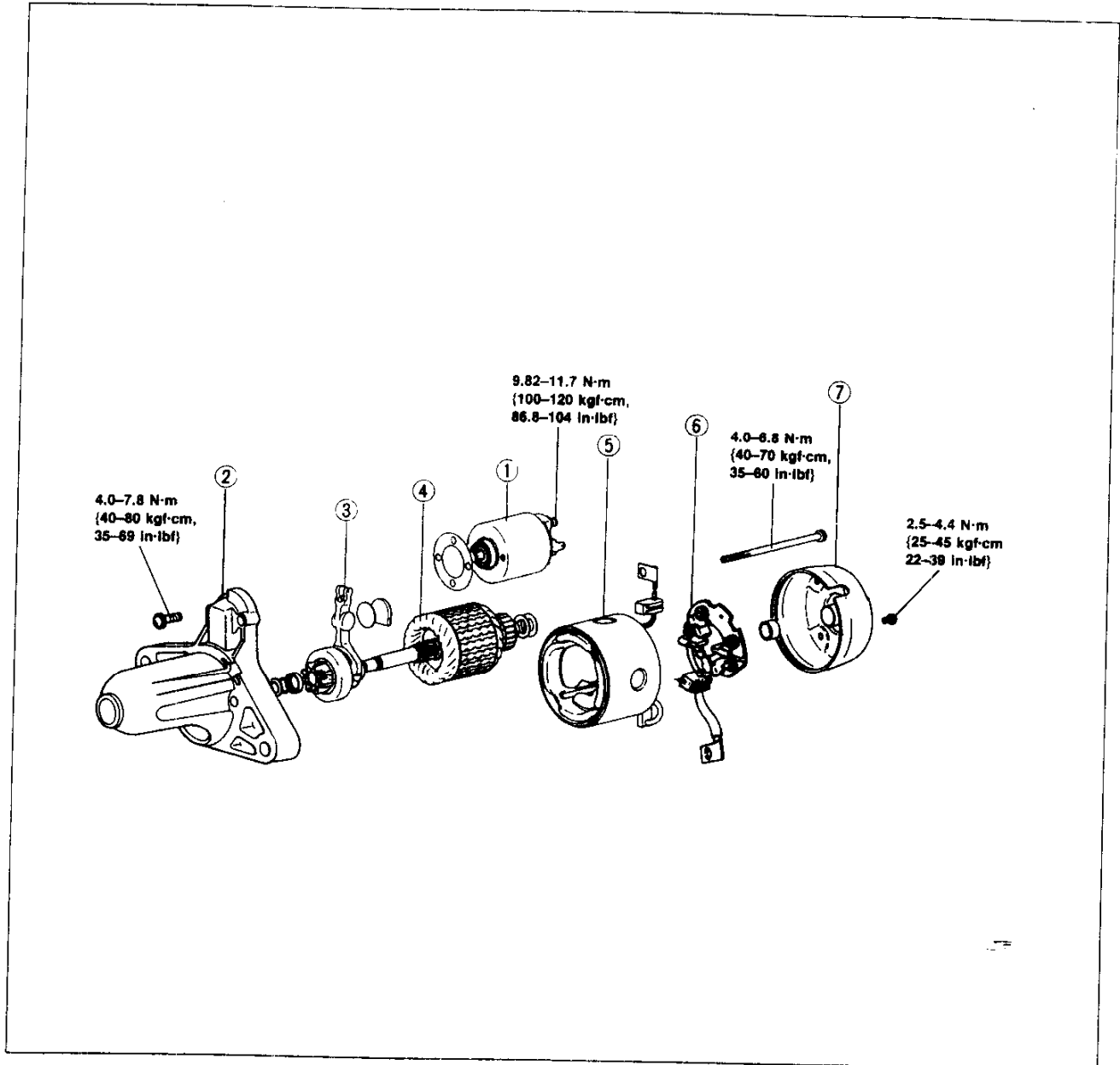

37U0GX-013

1. Magnetic switch
Performance inspection page G-27
Inspection page G-30
2. Front bracket
3. Drive pinion
Inspection page G-31
4. Lever

5. Armature
Inspection page G-30
6. Field coil
Inspection page G-30
7. Brush and Brush holder
Inspection page G-30
8. Rear bracket
9. Bearing

AT

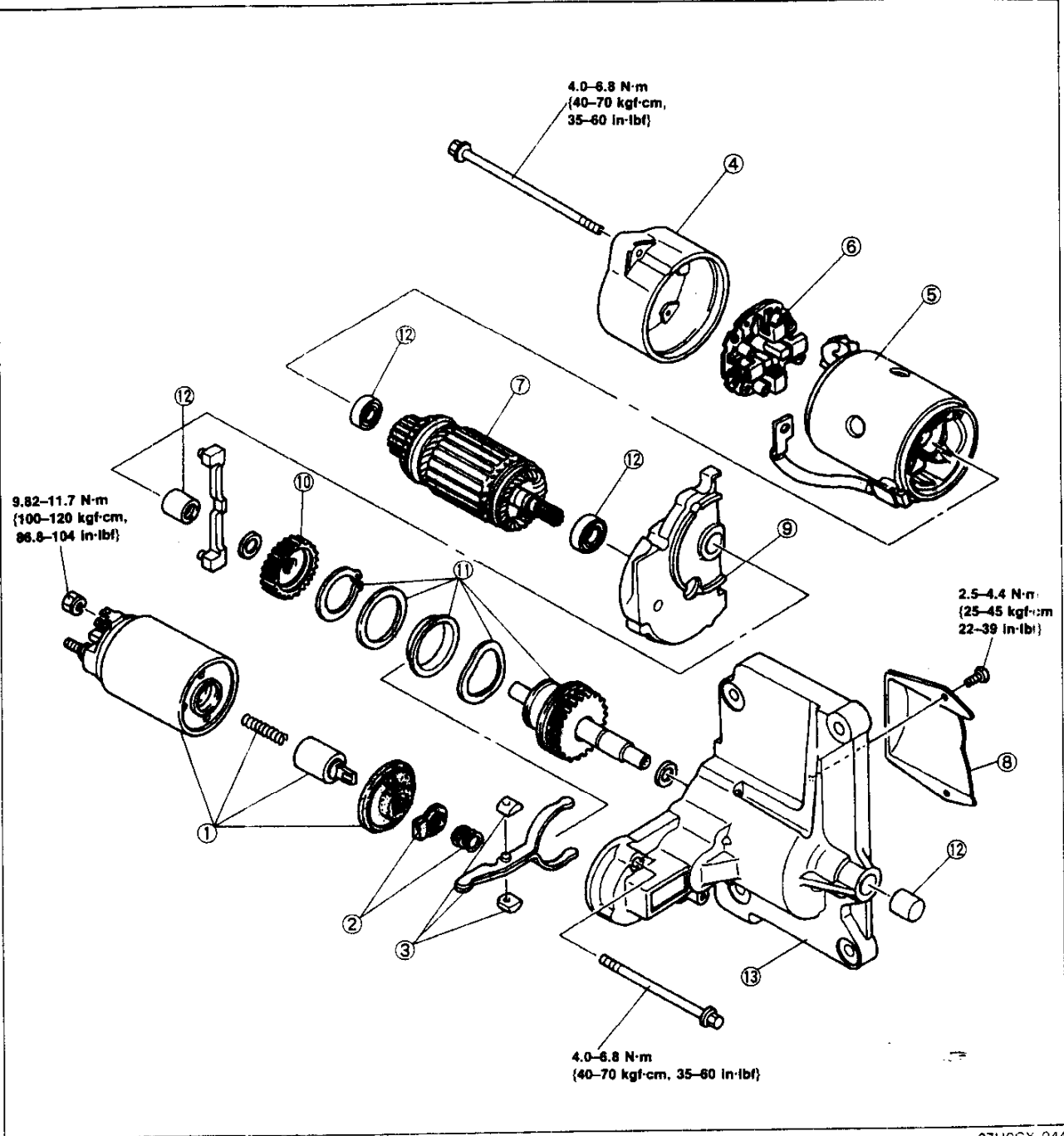

37U0GX-044

- 1. Magnetic switch
Performance
Inspection ... page G-27
Inspection page G-30
- 2. Spring set
- 3. Lever set
- 4. Rear bracket

- 5. Field coil
Inspection page G-30
- 6. Brush and Brush holder
Inspection page G-31
- 7. Armature
Inspection page G-30
- 8. Cover

- 9. Center bracket
- 10. Reduction gear
- 11. Pinion shaft assembly
(Overrunning clutch)
Inspection page G-31
- 12. Bearing
- 13. Front bracket

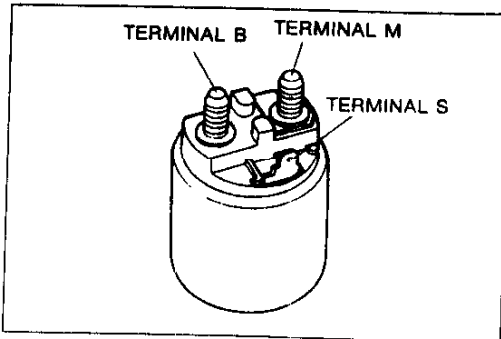

37U0GX-055

Inspection

Magnetic switch

- Check the continuity as shown.

Inspection point	Continuity
Terminal S-M	Yes
Terminal M-B	No
Terminal S-Body	Yes

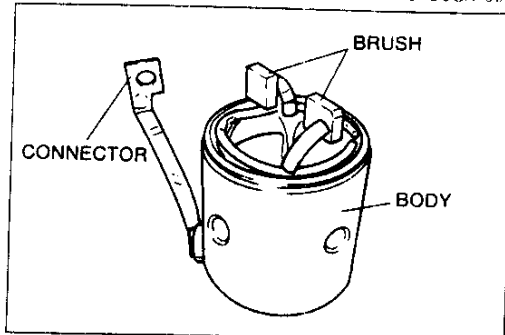

37U0GX-056

Field coil

- Check the continuity as shown.

Inspection point	Continuity
Brush - Connector	Yes
Body - Connector	No

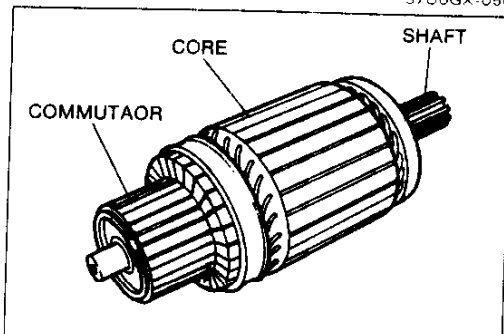

37U0GX-057

Armature

1. Check the continuity as shown.

Inspection point	Continuity
Commutator - Core	Yes
Commutator - Shaft	No
Core - Shaft	No

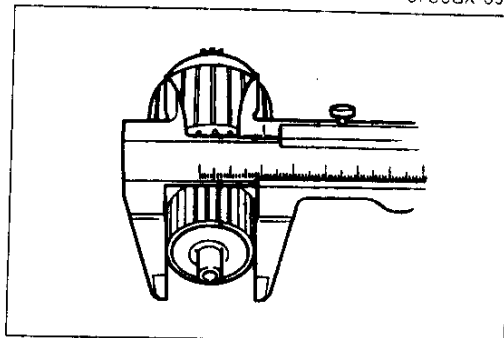

37U0GX-058

2. Replace the armature if the outer diameter of the commutator is almost at or less than the minimum.
3. If the commutator surface is dirty, wipe it with a cloth; if it is rough, repair it with a lathe or fine sandpaper.

Minimum diameter

32.0 mm {1.26 in}

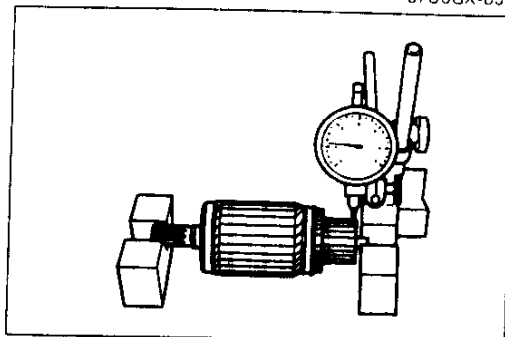

37U0GX-059

4. Place the armature on V-blocks, and measure the runout by using a dial indicator.
5. If the runout is not within specification, repair the armature by using a lathe or replace it.

Runout: 0.05 mm {0.002 in}

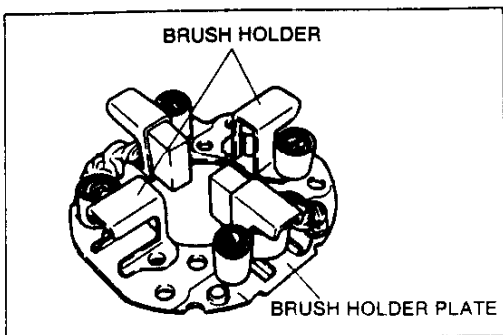

37U0GX-060

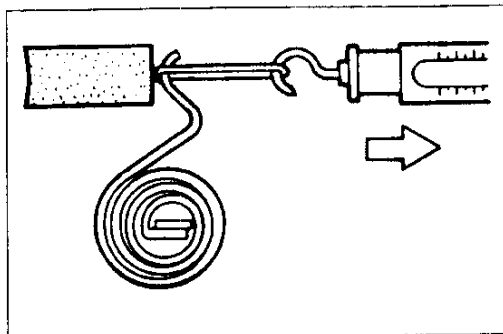

37U0GX-061

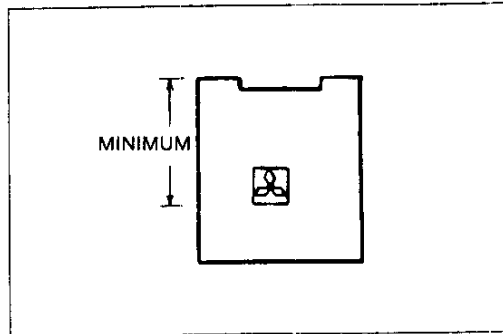

37U0GX-062

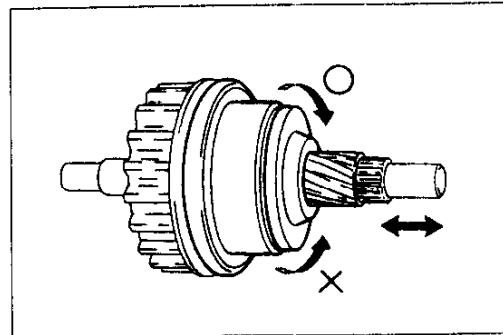

37U0GX-063

Brush and Brush holder

1. Check for continuity between the insulated brush and the plate. Repair or replace if there is continuity. Also check that the brush slides smoothly inside the brush holder.

2. Measure the force of the brush spring by using a spring balance.

Standard: 18.6–22.6 N {1.89–2.31 kgf, 4.16–5.09 lbf}
Maximum: 6.9 N {0.7 kgf, 1.5 lbf}

3. Replace the spring if not as specified.

4. If a brush is worn almost to or beyond the wear limit, replace all of the brushes.

Specification	MT	AT
Standard mm {in}	17 {0.67}	18 {0.71}
Minimum mm {in}	11 {0.43}	11 {0.43}

Overrunning Clutch

1. Turn the pinion shaft by hand while holding the over-running clutch.
2. Replace the overrunning clutch if the pinion turns in both or in neither direction.

Note

- Do not wash the overrunning clutch with solvent, as it is packed with grease.

INTERLOCK SWITCH

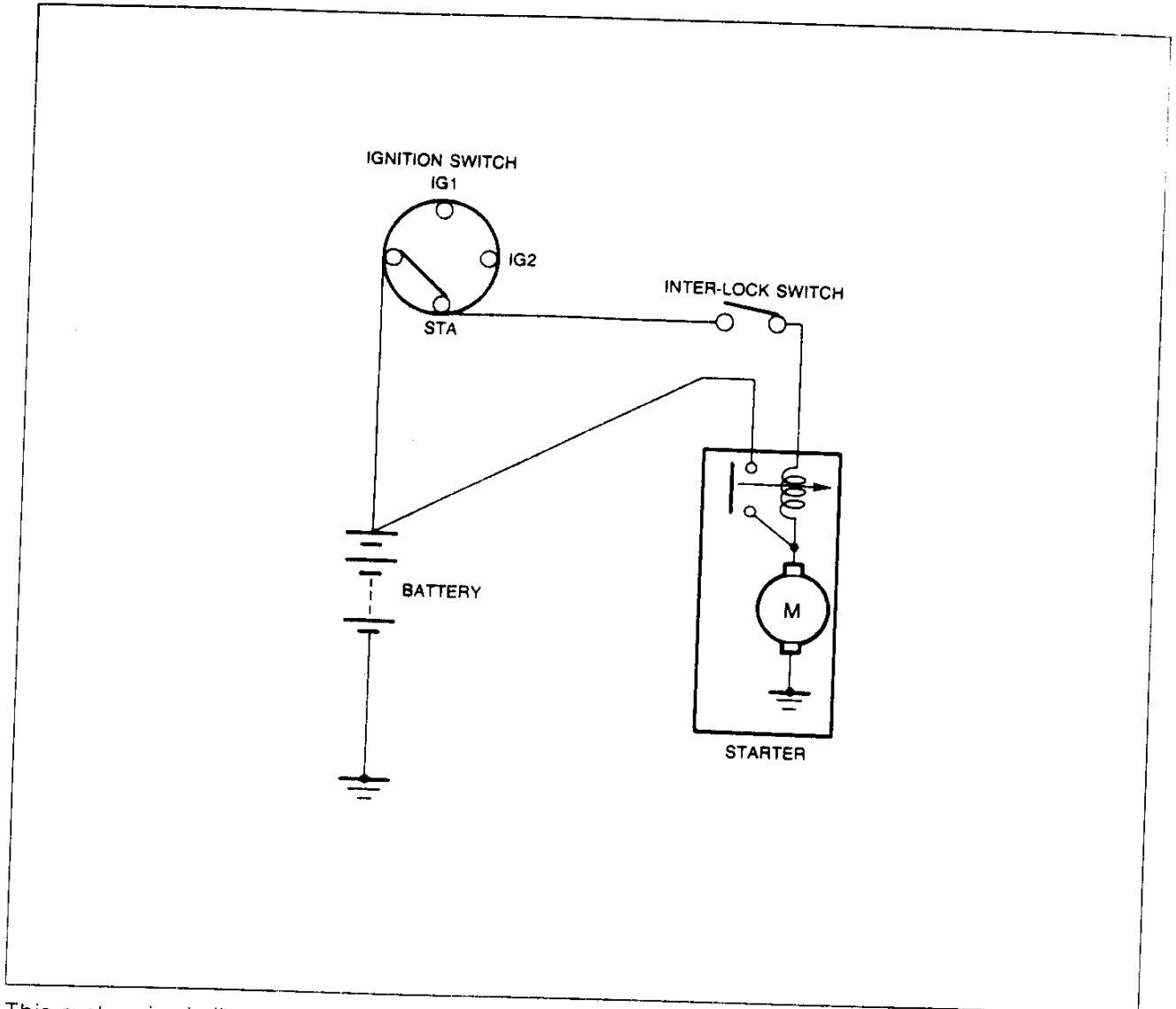

This system is similar to that of the inhibitor switch on at AT vehicle. If the clutch pedal is not depressed during starting, battery power will not be supplied to the starter and the starter will not operate.

77U0GX-C15

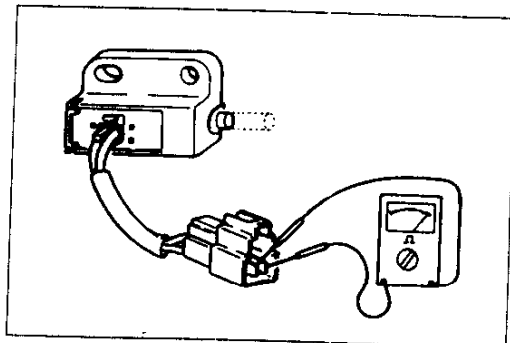

77U0GX-016

Inspection

1. Disconnect the interlock switch connector.
2. Connect a circuit tester to the switch.
3. Check the continuity.

Pedal	Continuity
Depressed	Yes
Released	No

4. If not as specified, replace the switch.